

2x

1/16" PLY BRACES, TOP
& BOTTOM (TYP.)

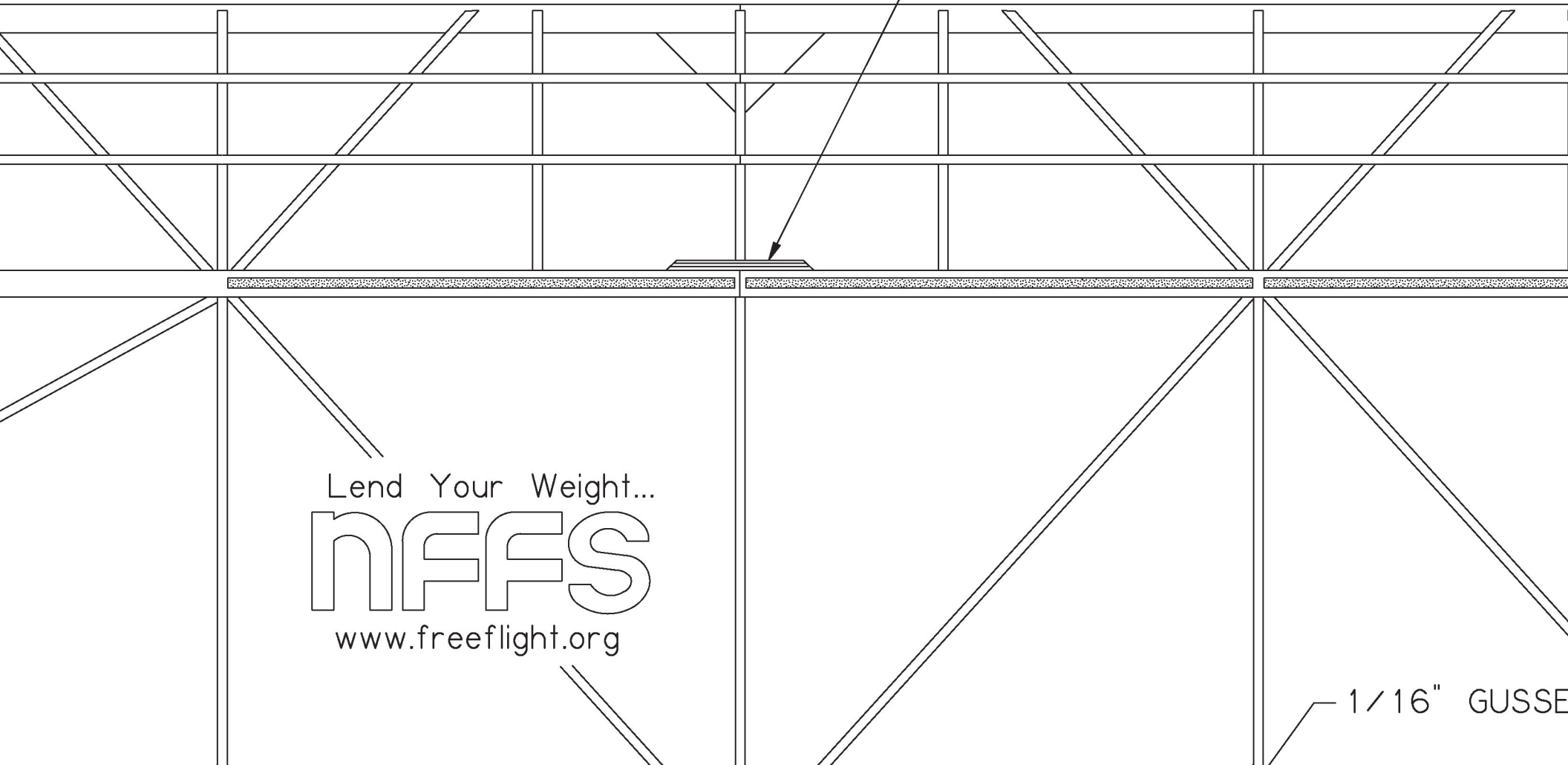

Lend Your Weight...

nfffs

www.freeflight.org

1/16" GUSSE

1/16" VERT. GRAIN (TYP.)

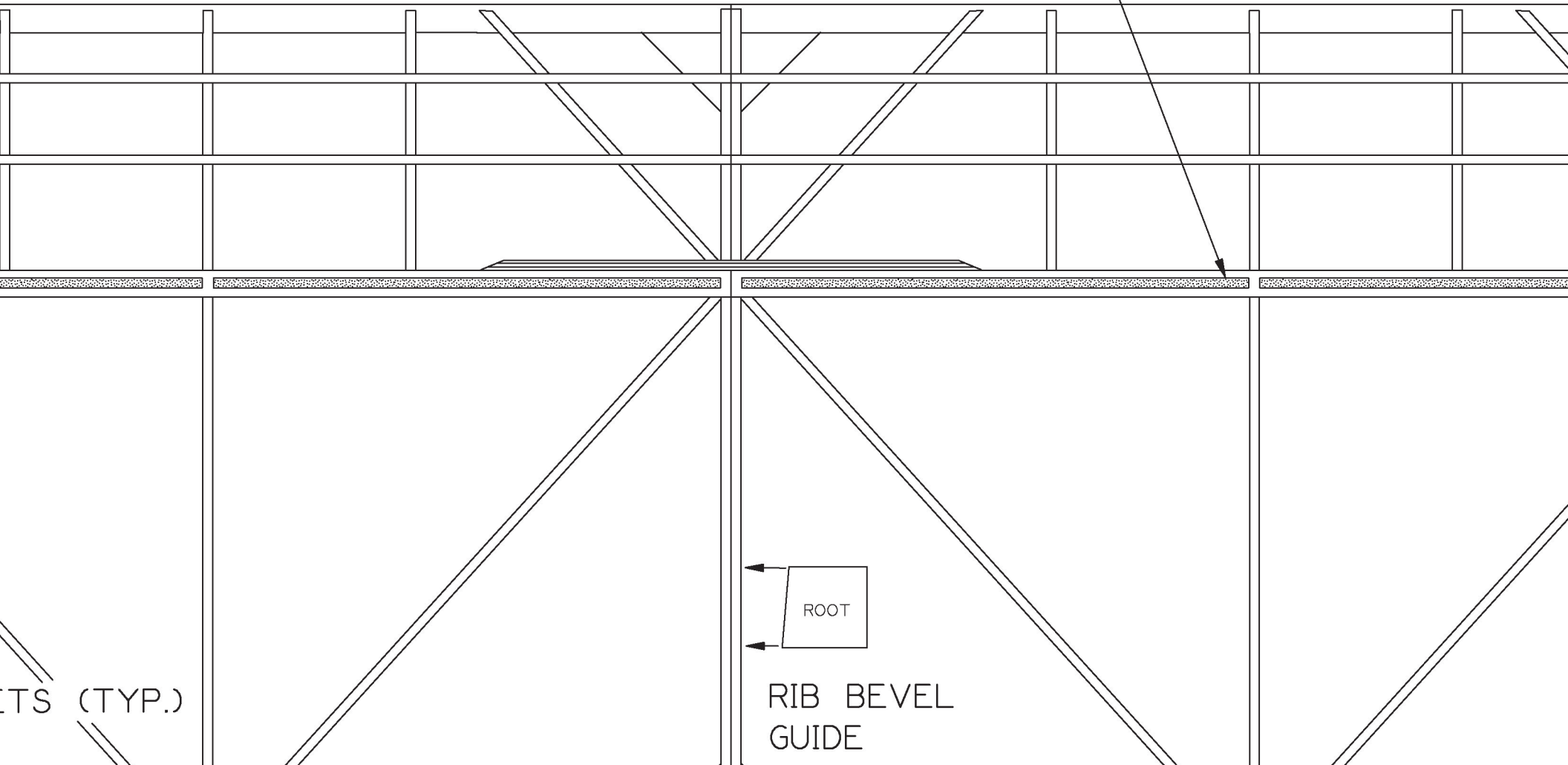

ROOTS (TYP.)



RIB BEVEL
GUIDE

1/8 x 3/16"
MEDIUM

BLOCK UP 3/32" HERE FOR WASH-IN
(DURING CONSTRUCTION)

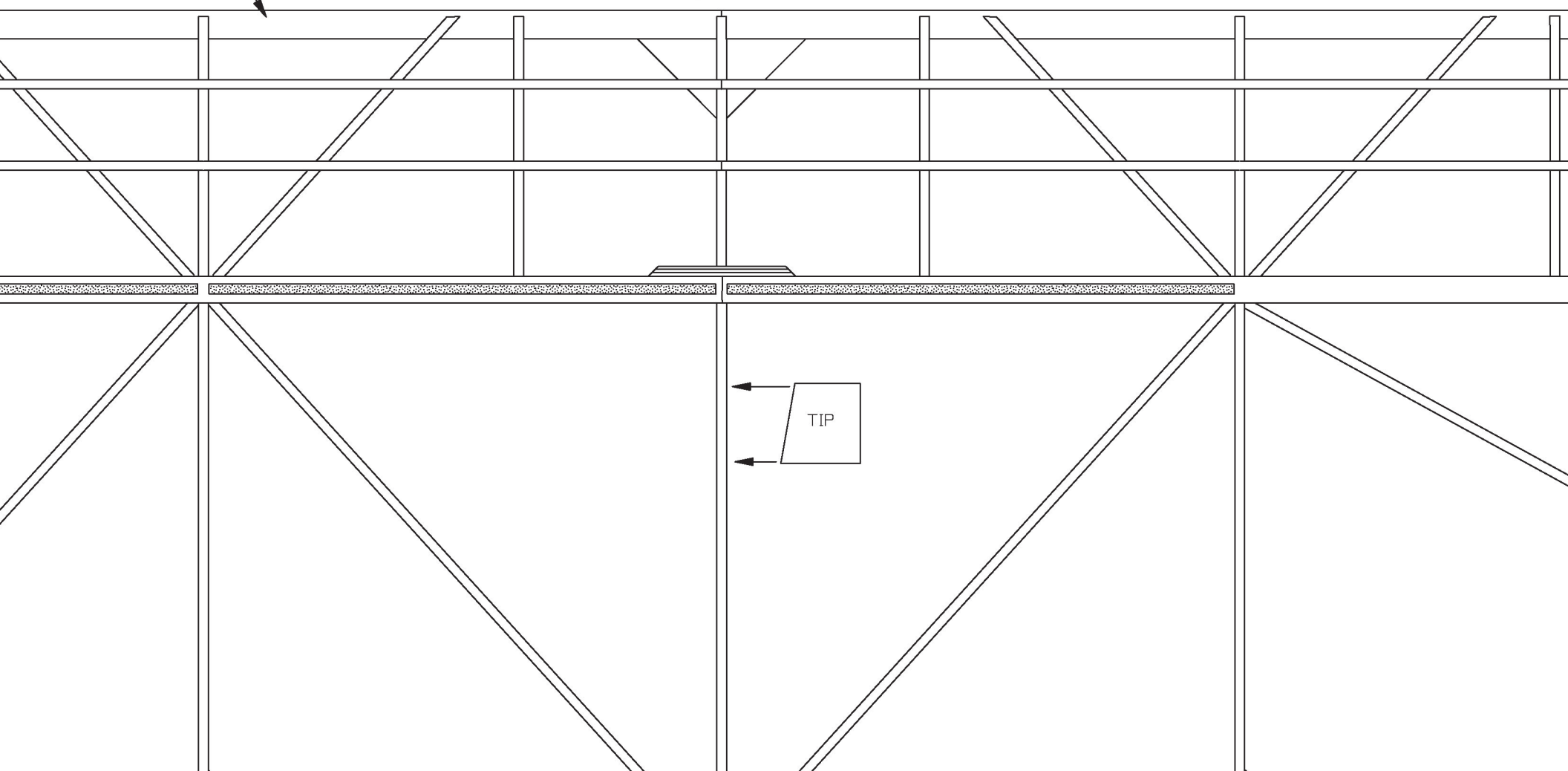

TIP



3/16 X 1/16" VERY HARD
BALSA, SPRUCE ON INNER
PANELS

THRUST OFFSETS:
3° LEFT, 0° DOWN

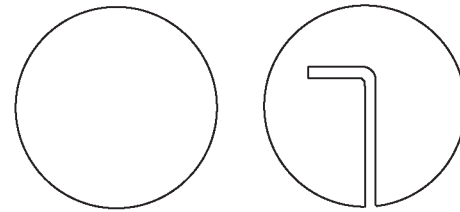

1/16" PLY

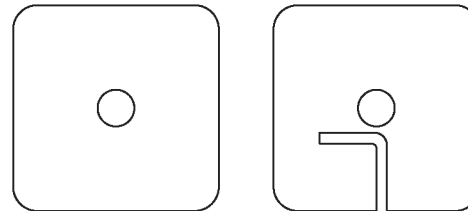

LARGER FIREWALL FOR "SPIDER"
TYPE MOTOR MOUNTS

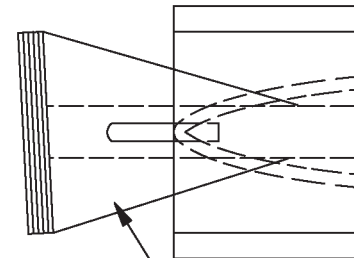
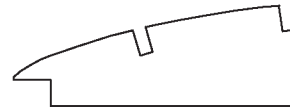
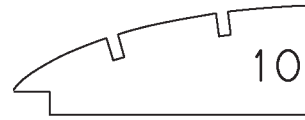

SC

OPTIONAL MACHINED ALUMINUM MOTOR
MOUNT FROM TEXASTIMERS.COM - A
NICE UPGRADE...STRONGER AND LIGHTER.

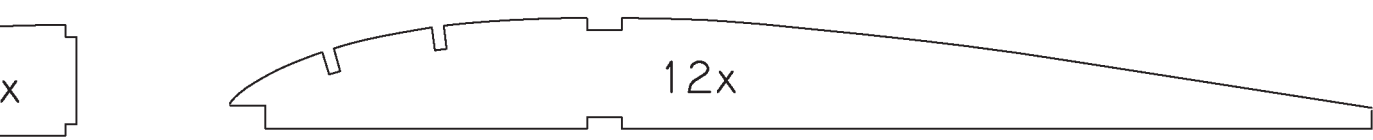
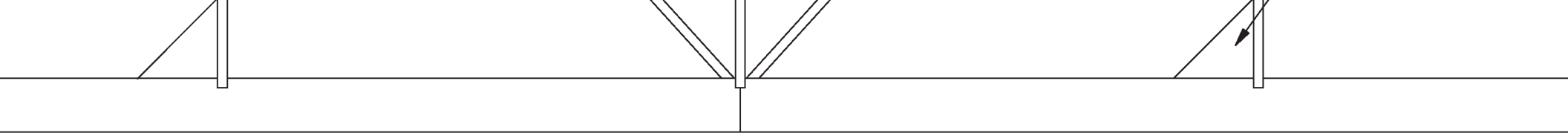

ALL RIBS:
1/16" LIGHT

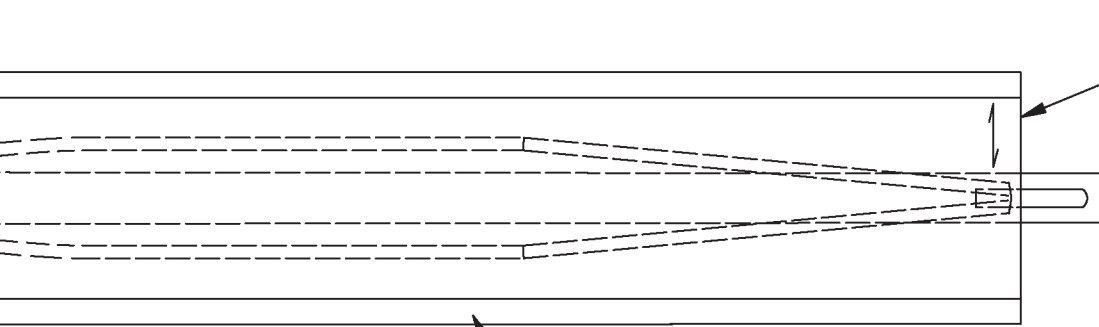
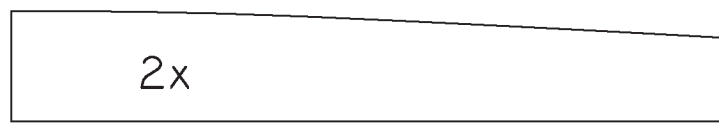
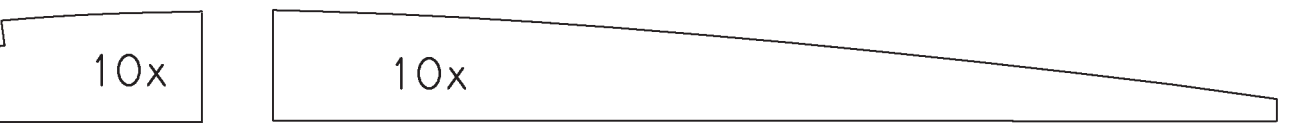

1/8" SHEET SADDLE

TAILBOOM

SOLID Balsa FILL

1/16 x 1/8" HARD RAILS

1/8" SQ. MED.-HARD

COVER PYLON WITH TISSUE OR LIGHT GLASS CLOTH

1/16" LIGHT SHEET

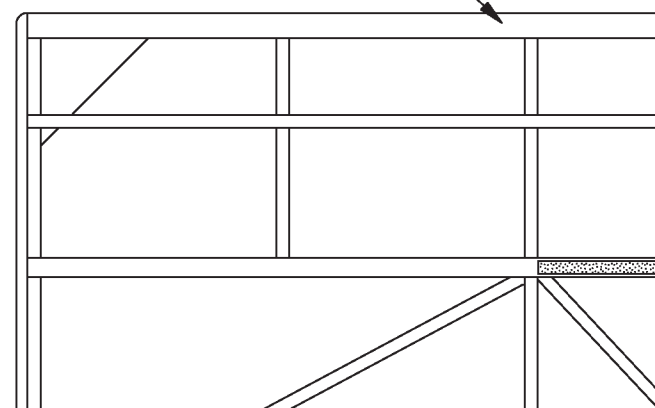

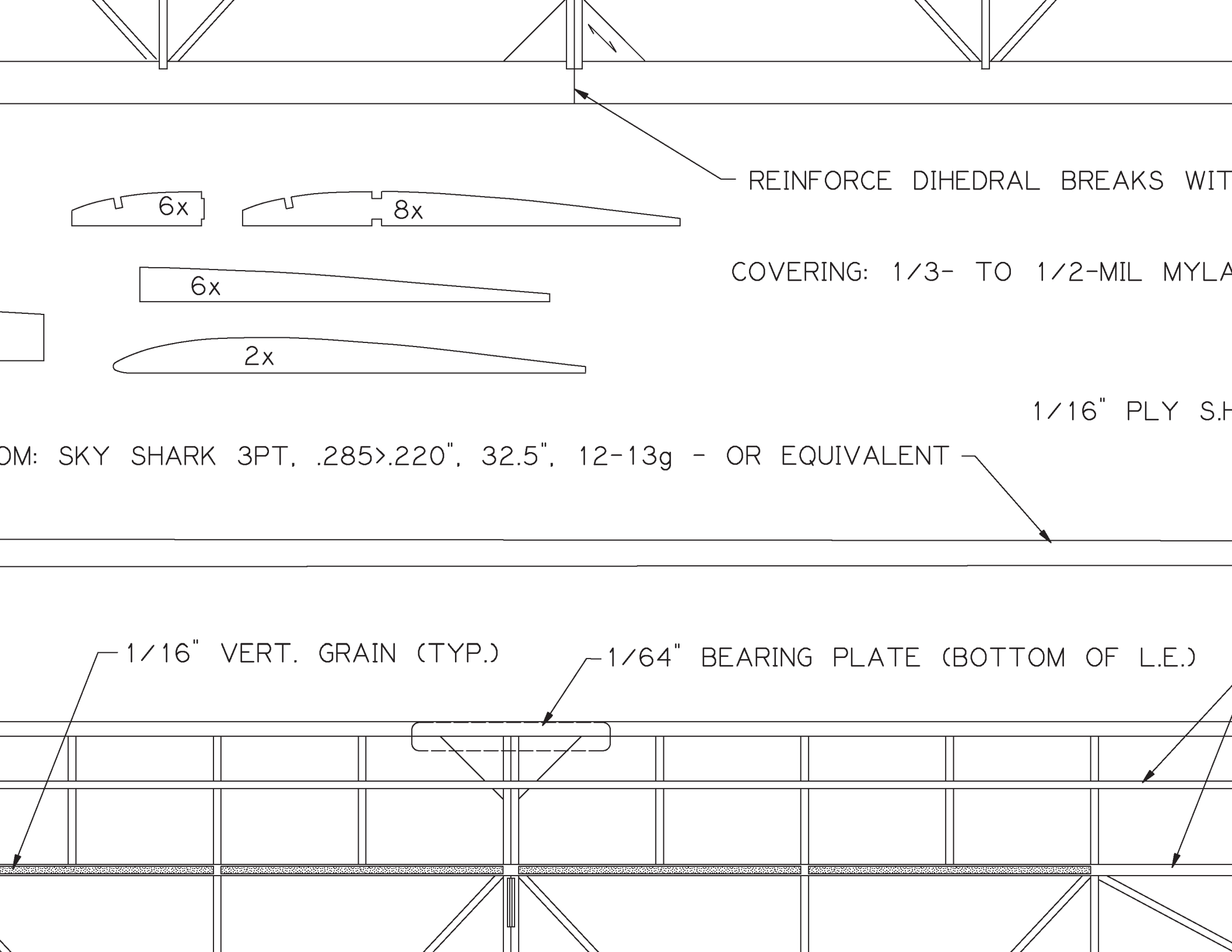

Aw = 229 SQ. IN. (FLAT).

H 1-OZ. GLASS CLOTH

1/8 x 3/8" MEDIUM

AR, DOCULAM, OR POLYSPAN

DIHEDRAL SKET

1/4 SCAL

H.O.C. MOUNT

1/32" PLY BASE

7/8"

1/16 x 3/32"

1/16" O.D. ALUM.
LINE GUIDE

IMPORTANT:
OMISSION OF

ALL MATERIAL IS 4-6 LB./CU. FT. BALSA
UNLESS OTHERWISE NOTED

Laser-
Email <

TCH
E

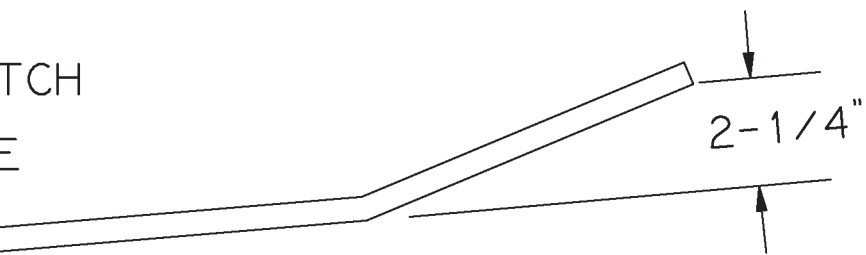

DIHEDRAL BRACES
1/16" PLY



SKID PROTECTS BATTERY ON LANDING.
SKID IS A FIRE HAZARD.

cut kits of this design are available.
<mailto:ddeloach@comcast.net>

SECURE MOTOR WITH #1 OR #2 X 1/4"
PAN HEAD WOOD SCREWS

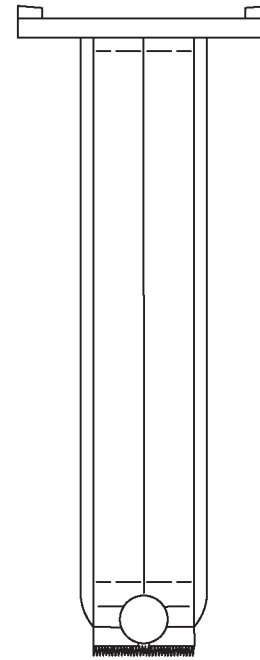

PYLON/SADDLE
CUTAWAY

DOWELS

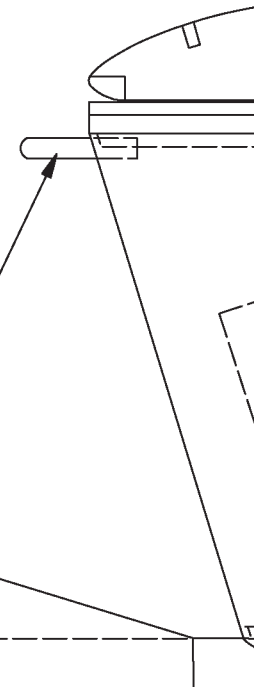

.047" WIRE SKID

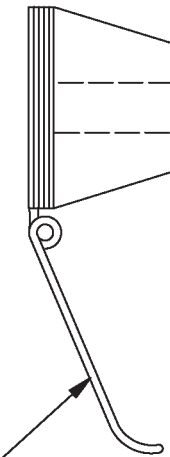

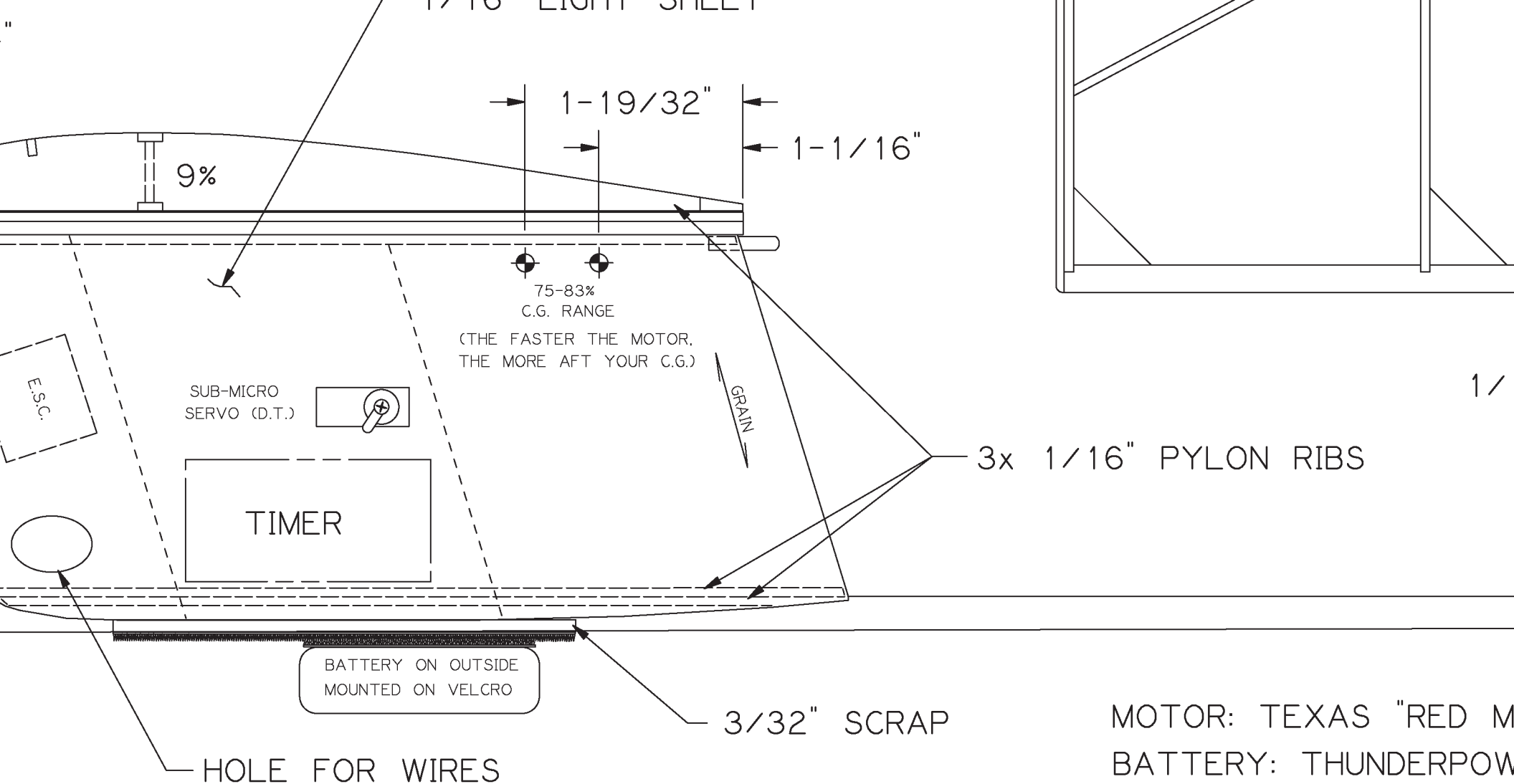

LOCATE PYLON LAST TO ACHIEVE 78% C.G.
WITH 1 GRAM OF CLAY ON TAIL (IMPORTANT!)

MOTOR: TEXAS "RED M
BATTERY: THUNDERPOW
SPEED CONTROL: 12A
PROP: 7.5x4 FOLDER A
TIMER: FROM WWW.STA

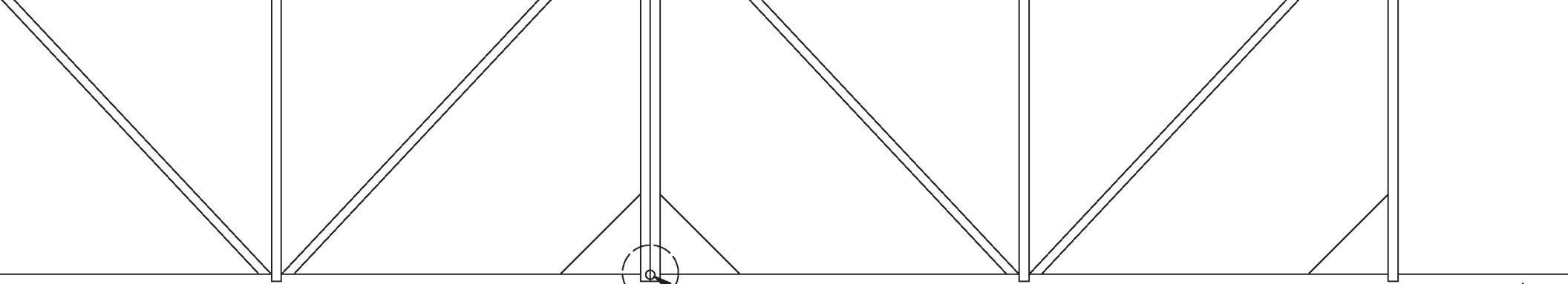

As =

16 x 3/16" MEDIUM

1/16" O.D. ALUM TUBING

1/32" PLY BASE, AFFIX AFTER COVER

TAP FOR 2-56

AX" OR 2205-2206 DRONE RACING IN 2500-2950 Kv
VER, GAONENG, OR TURNIGY, 300-500mAh, 2S, 65-80C
MINIMUM, 20-25A FOR THE STRONGEST MOTORS, BRAKE "ON"
ND HUB FROM TEXASTIMERS.COM, OR APC 6x6E OR 7x6E
RLINK-FLITETECH.COM OR WWW.TEXASTIMERS.COM

MICROBALLON,

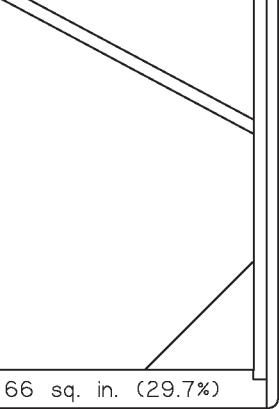

ING

40° DT ANGLE

2-56 NYLON SCREW

1/32" PLY BASE

12# MONOFILAMENT

3/32" SHEET
VERY LIGHT
C-GRAIN

3/32 x

TO D.T. TIMER

7%

GRAIN

GRAIN

1/32" PLY

CA FILLET

SCALE IN INCHES

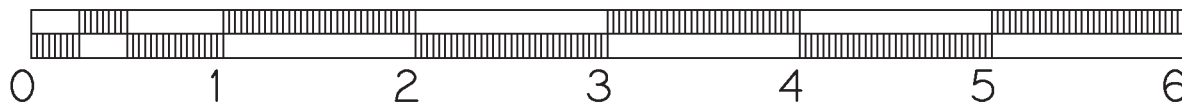

1/8"

Copyright 2021



and

ModelAviation

**Copying for resale of this drawing without
the written approval or consent of AMA
is expressly prohibited.**

IGHT COPPER WIRE

Plan No. 1126

MODEL AVIATION

Super Pearl 222-E

Free Flight Electric: E-36, A/B, F1S

By Don DeLoach - March, 2021

Outrunner motor and 2-cell Li-Poly
Wing Span: 35-3/8" projected