

1/32 Ply All Parts 1 ea.
Unless noted Otherwise

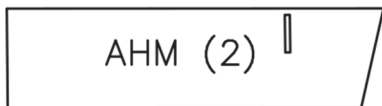

AHM (2)



WSF

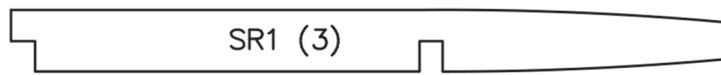

SR1 (3)

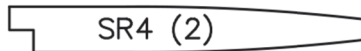

SR4 (2)



E4 (2)



E5

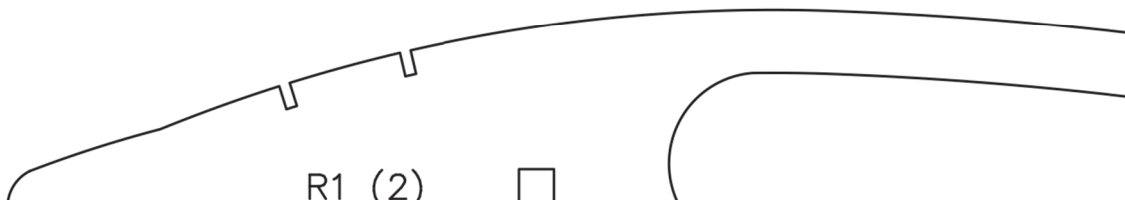

R1 (2)

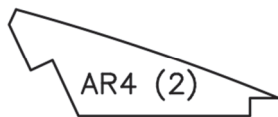
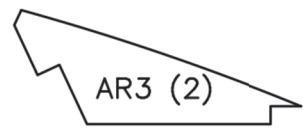
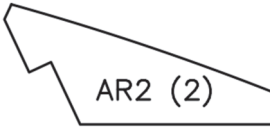
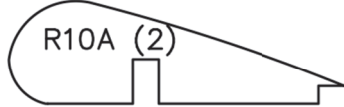
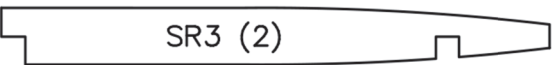
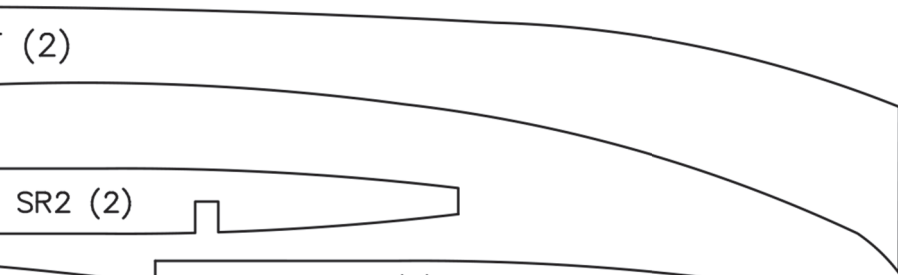
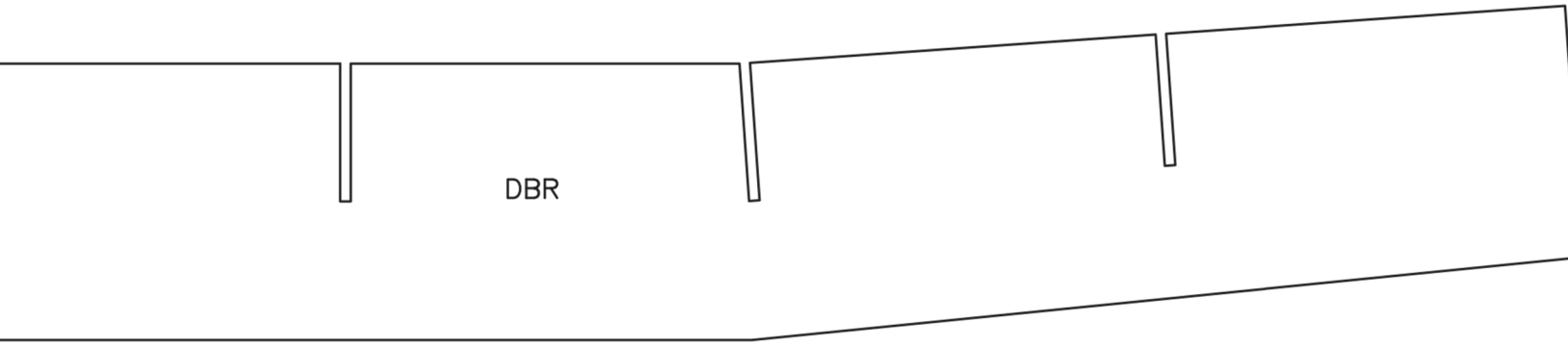

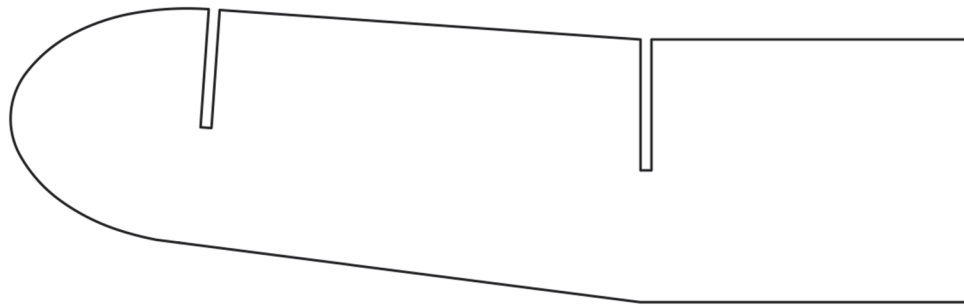
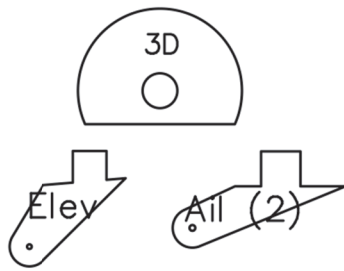
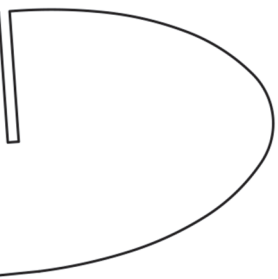

F2 (2)

FCB

RCB

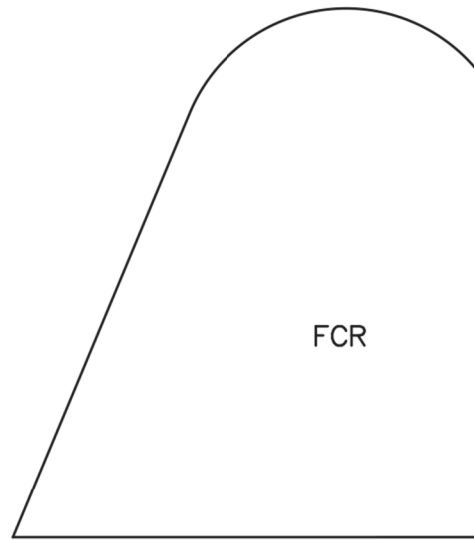
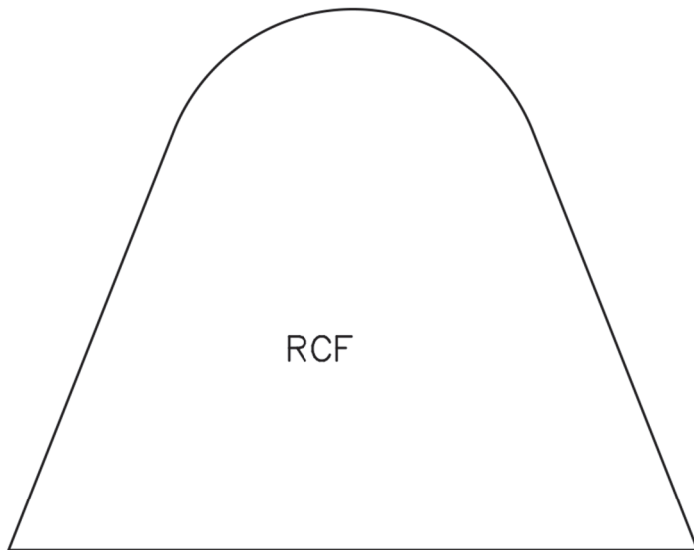
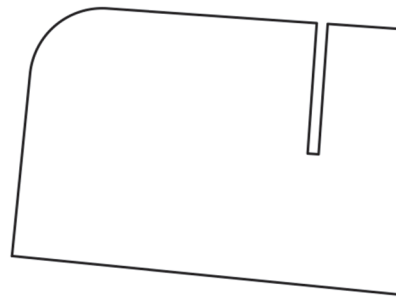
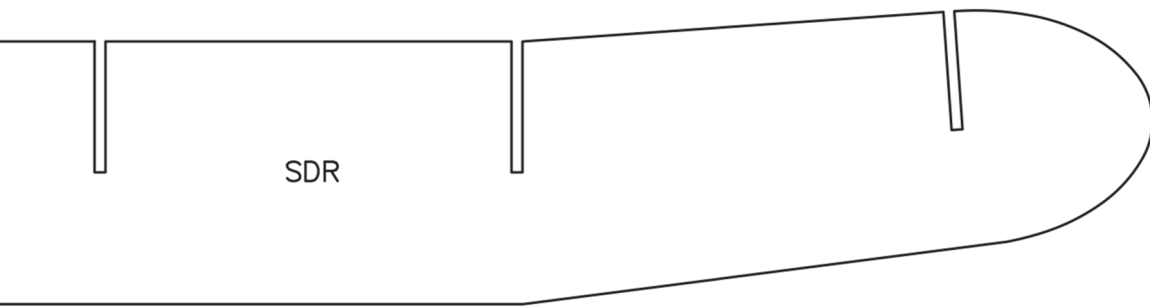

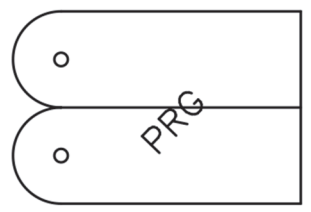
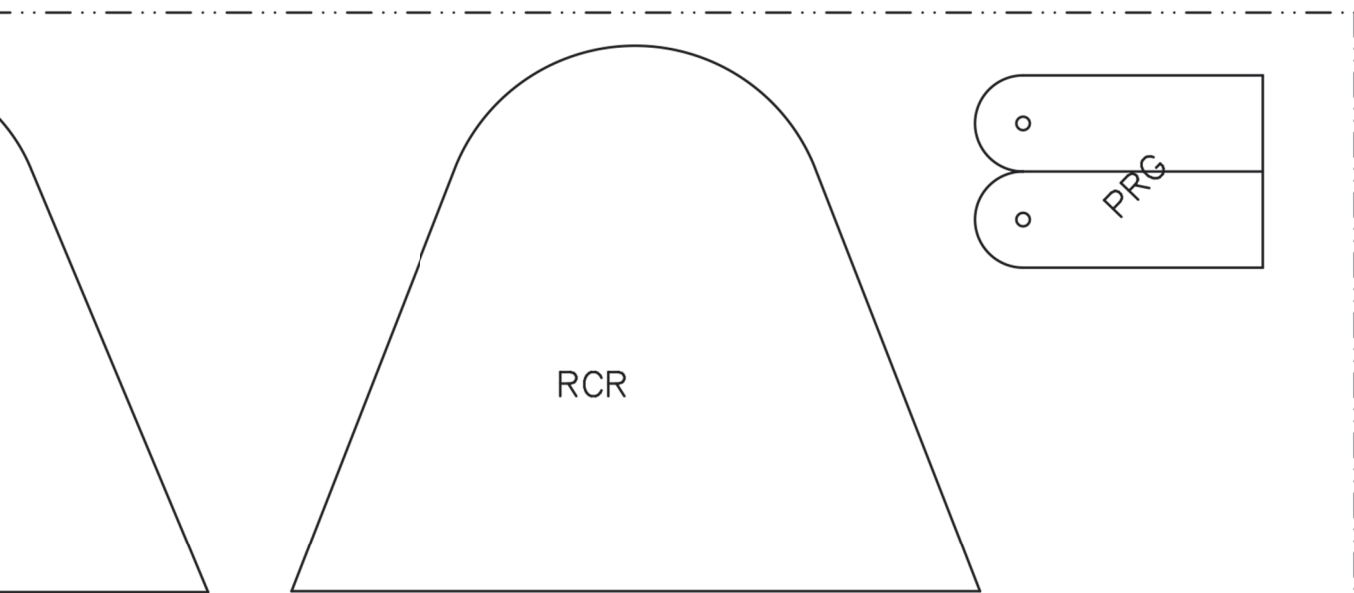
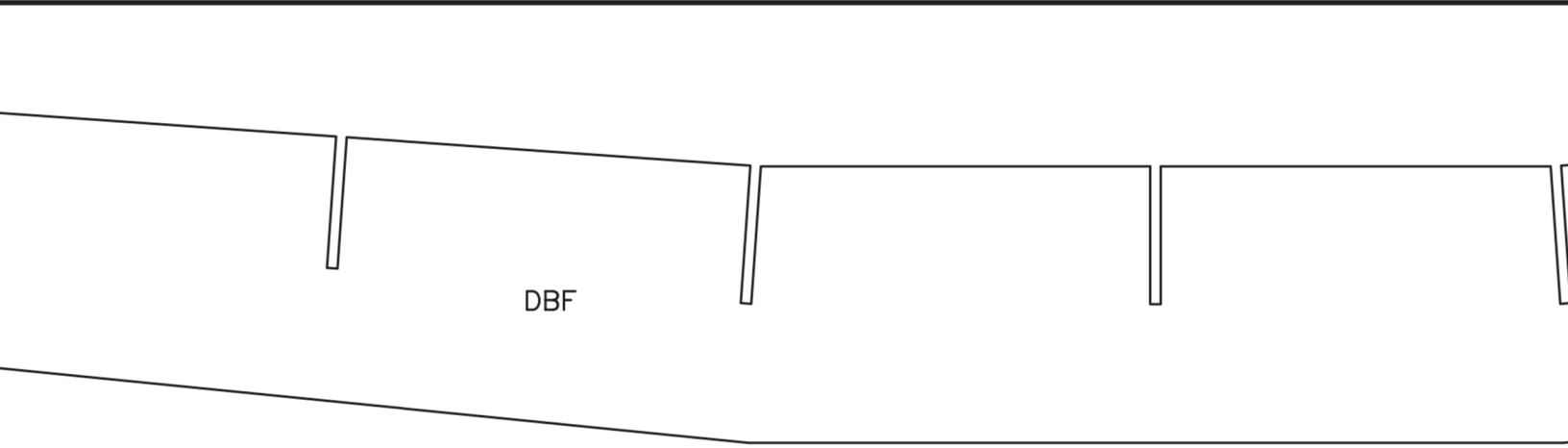

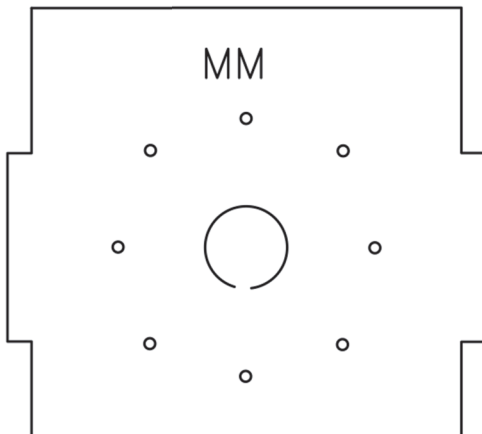
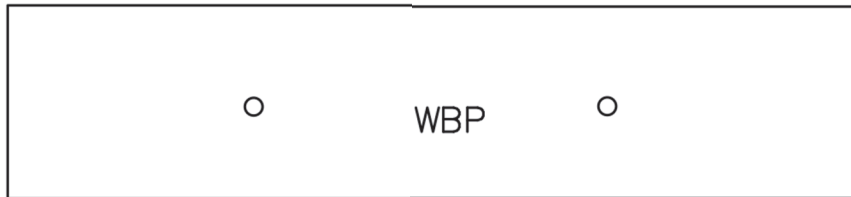
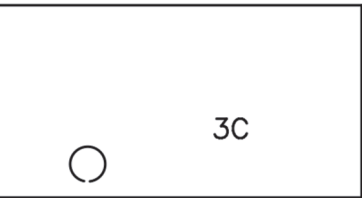
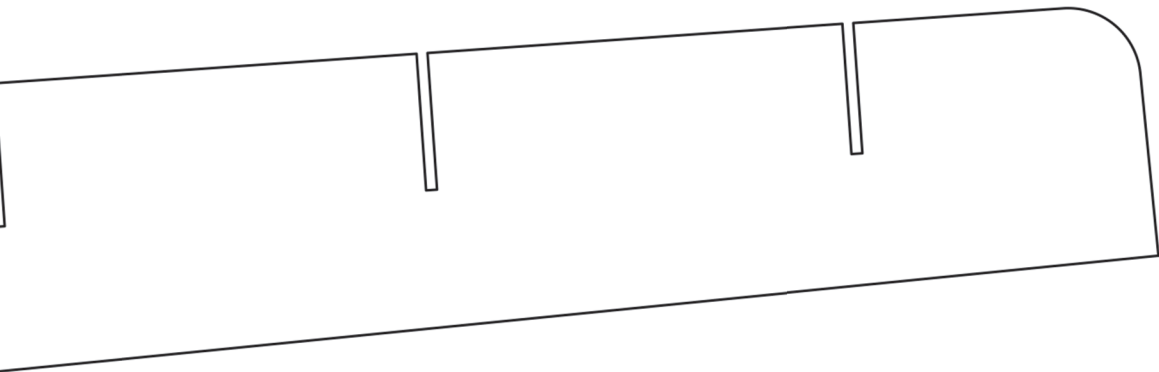

Lite Ply 1 ea. Req.

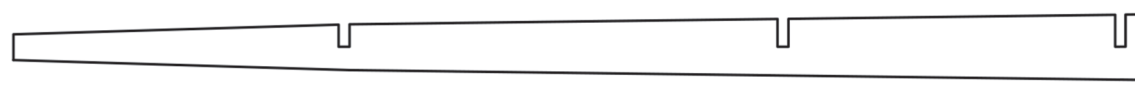
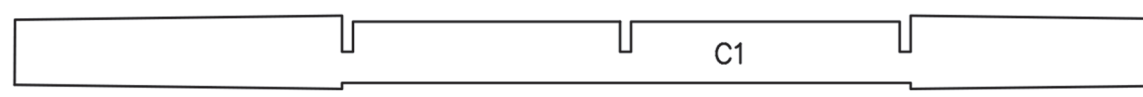
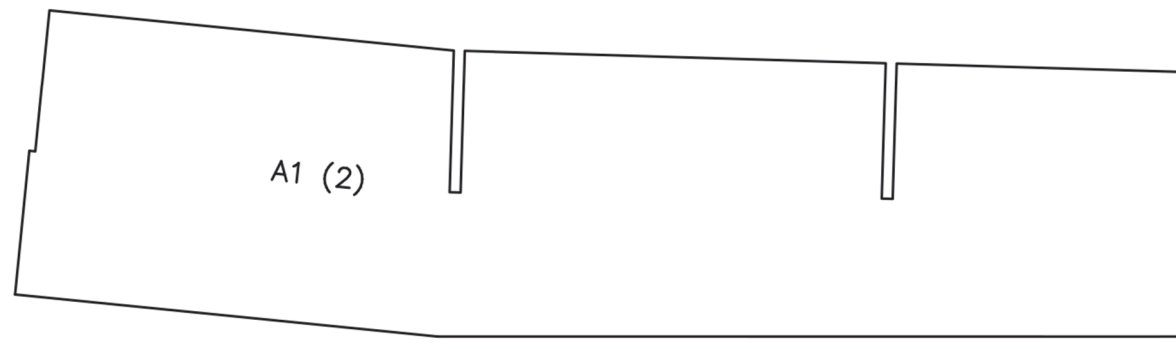
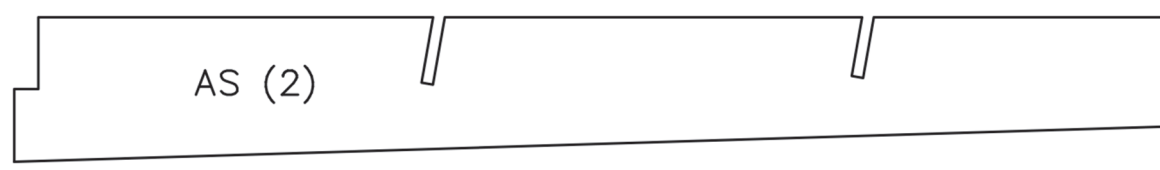
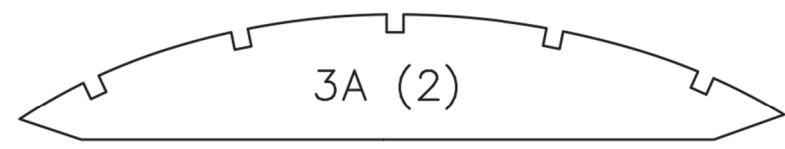
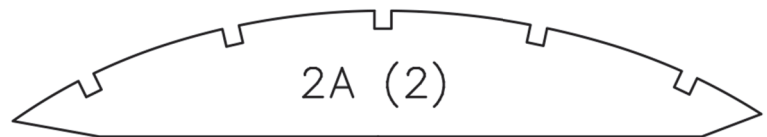
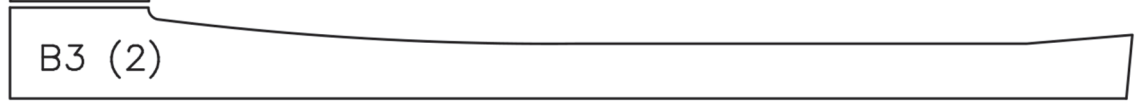
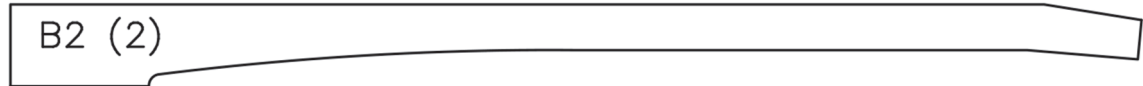
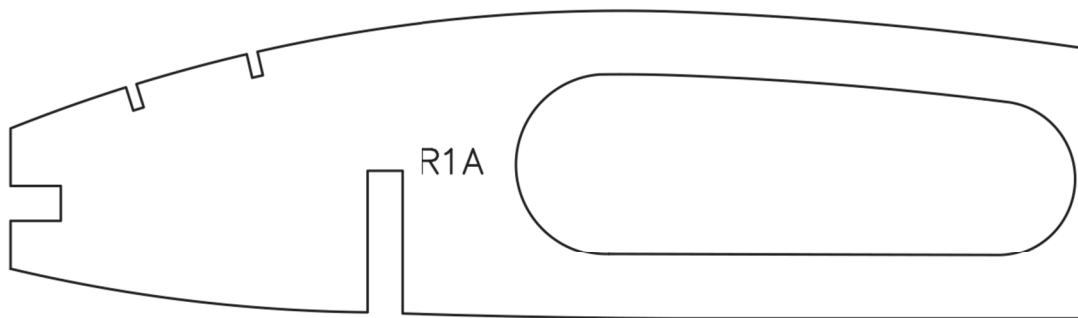
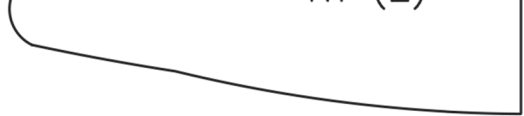

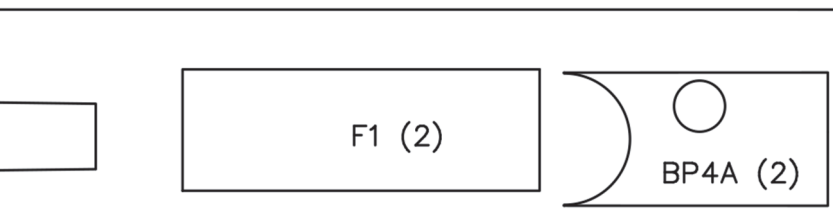
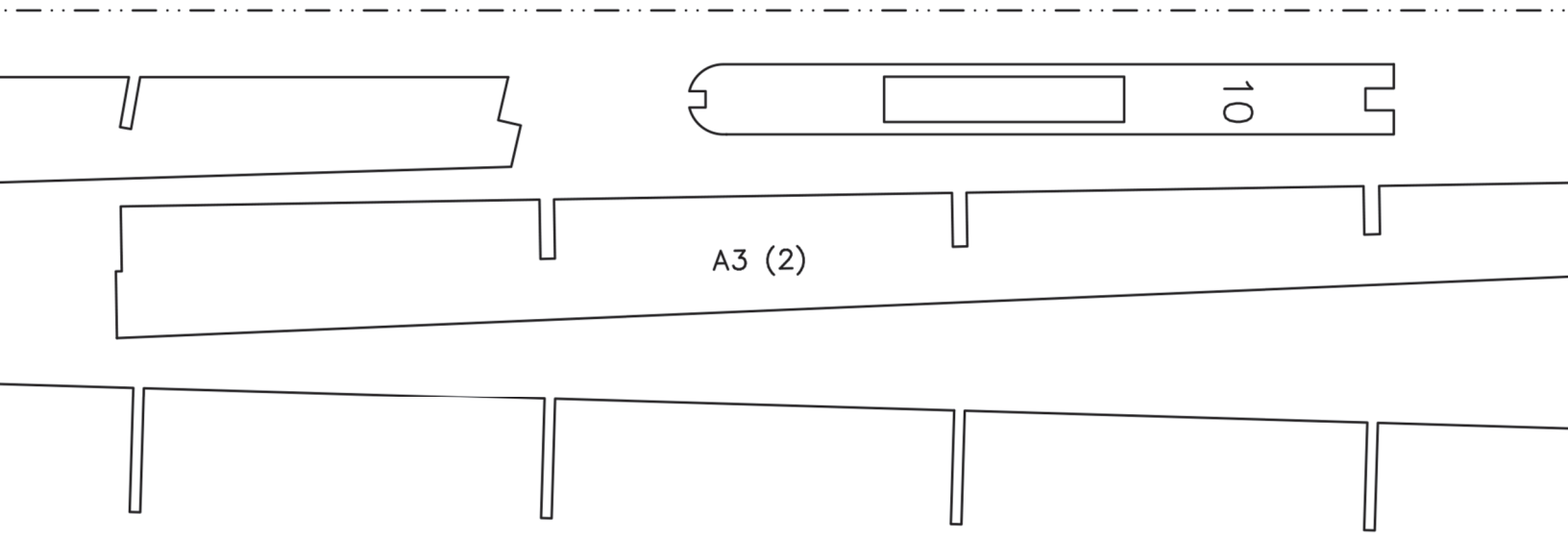
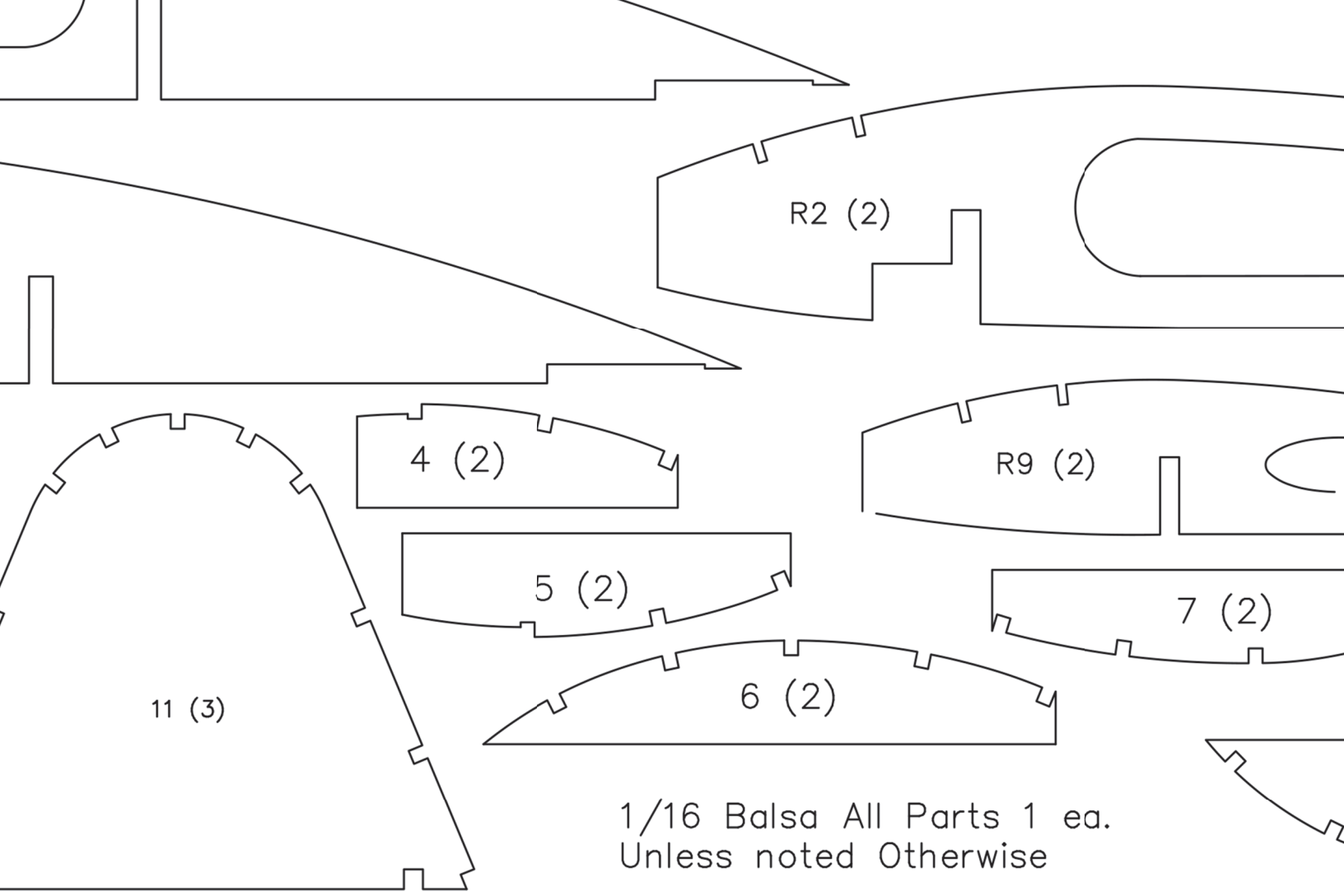

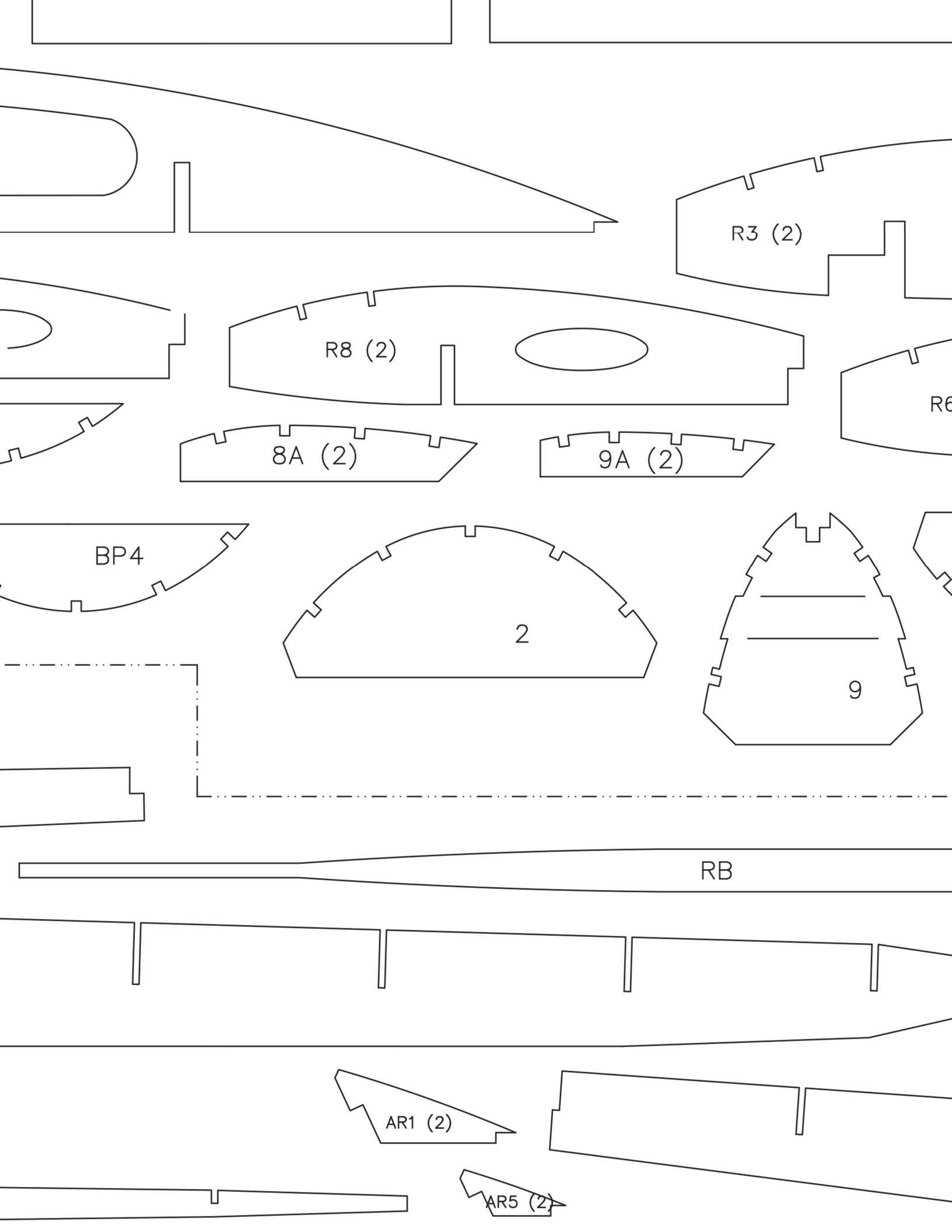

R3 (2)

R8 (2)

R6

8A (2)

9A (2)

BP4

2

9

RB

AR1 (2)

AR5 (2)

SM

R4 (2)

R5 (2)

S (2)

3B

2B

8B

3

BP2

LE2 (2)

D2 (3)

1A (2)

LE1



C5 (2)



C3

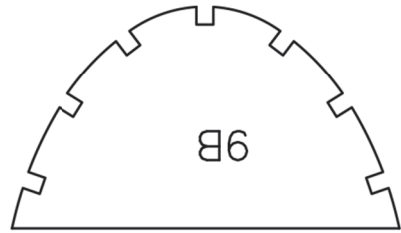
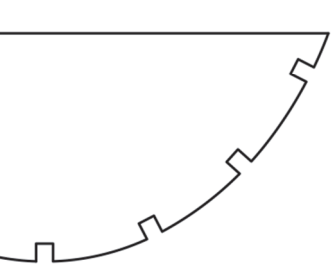
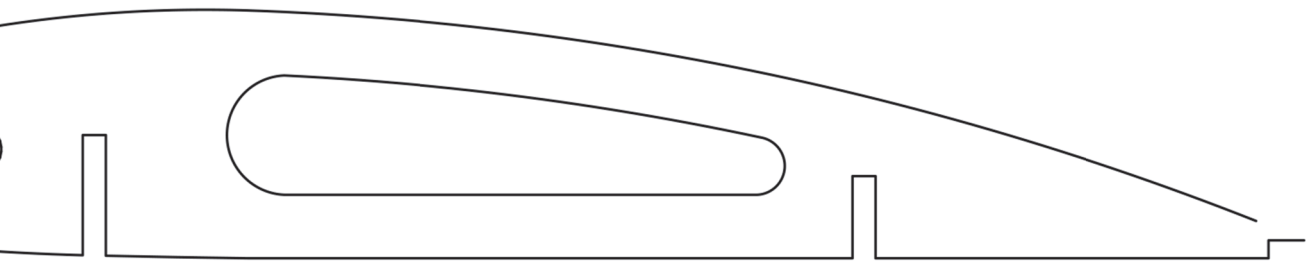
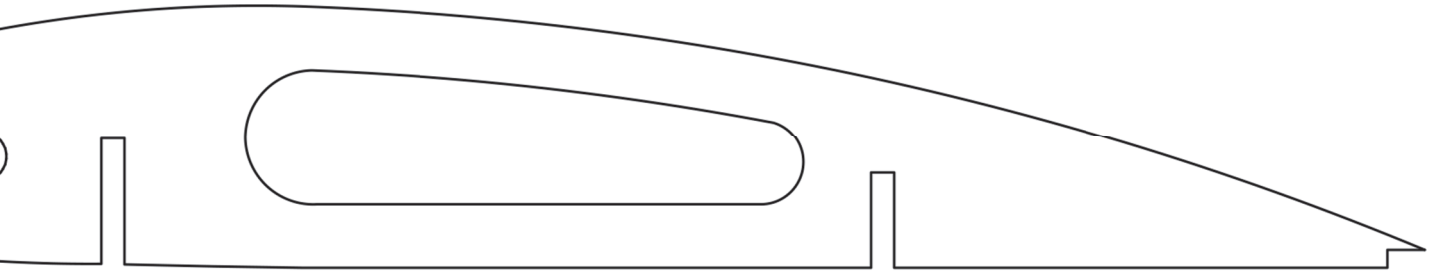

9B

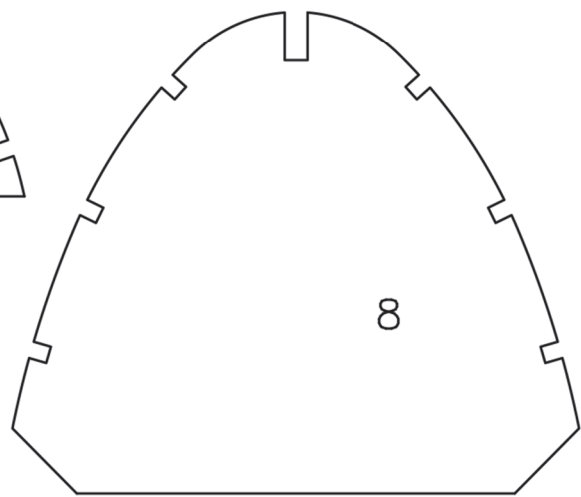

8

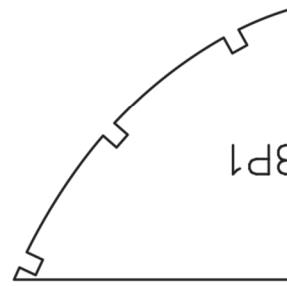

8P1

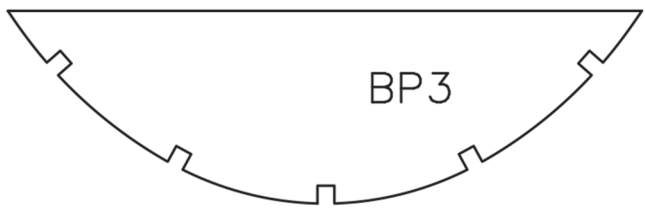

BP3

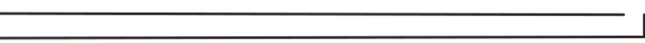
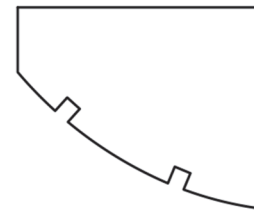

C4 (2)



C7 (4)



C8

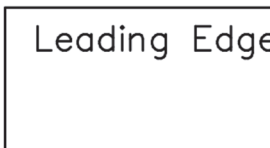

Leading Edge



D1



A3

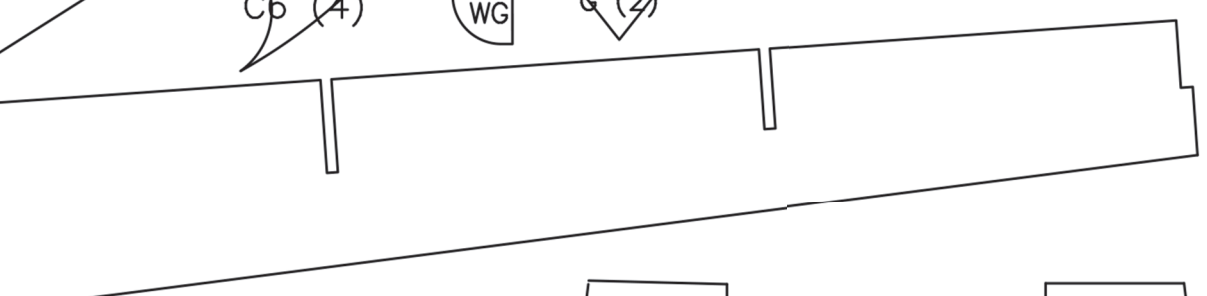
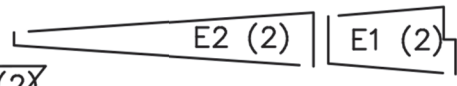
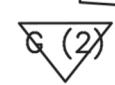
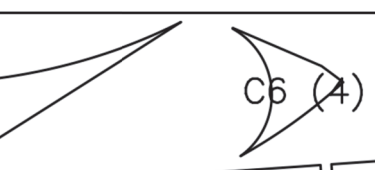
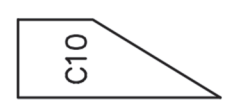
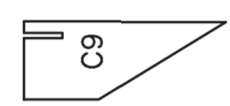
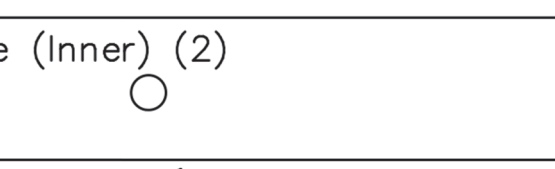
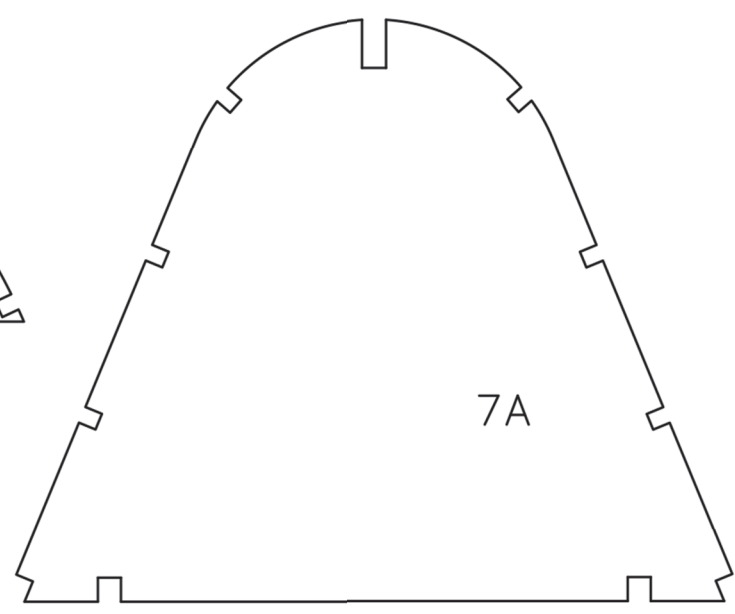
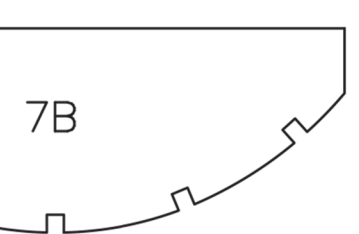
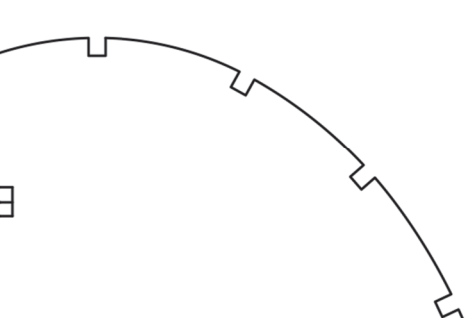
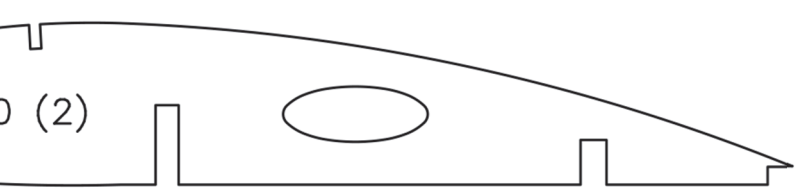
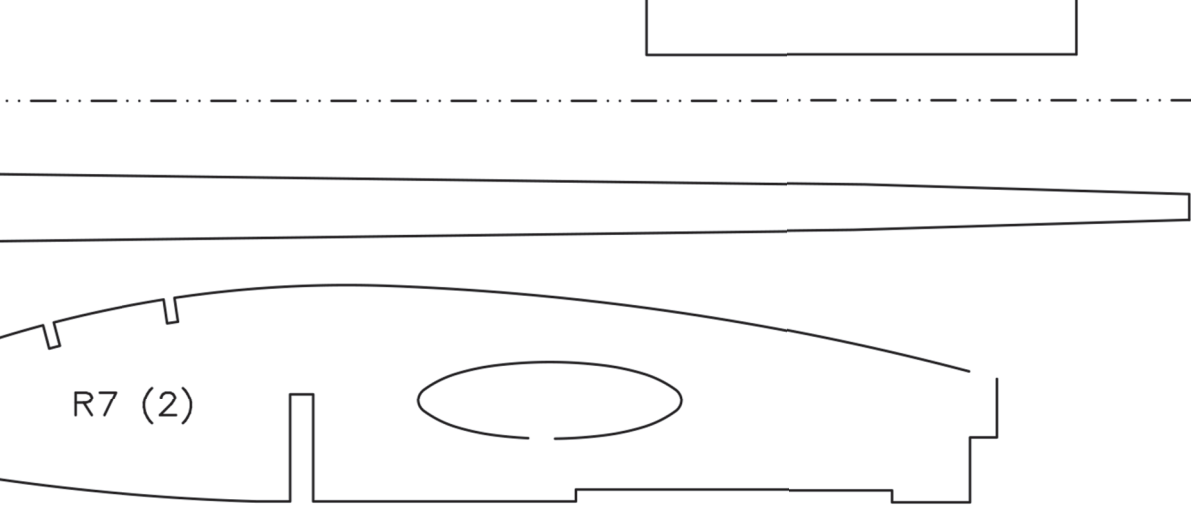

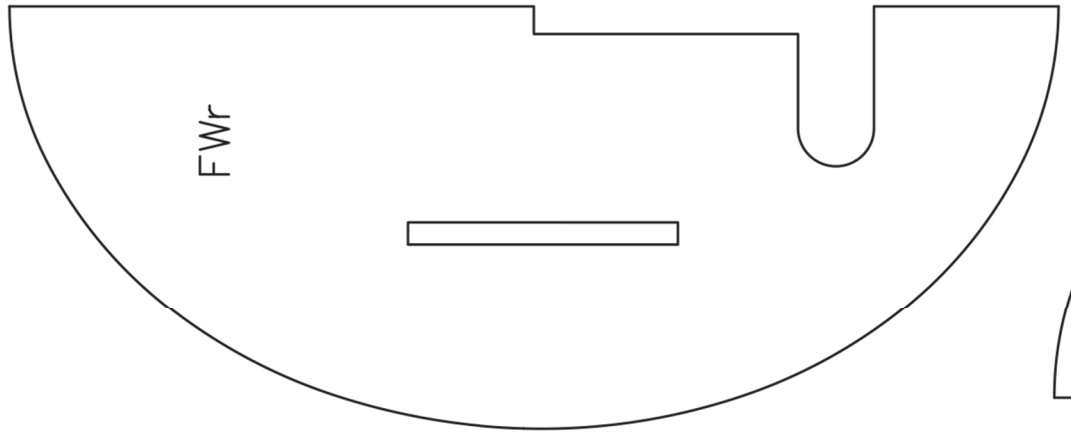

FWR

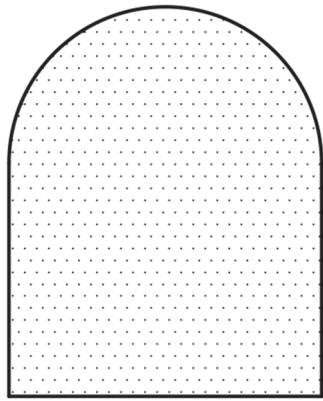

Front Canopy Frame
Make from 2 Laminations
of 1/16 x 1/8 Balsa

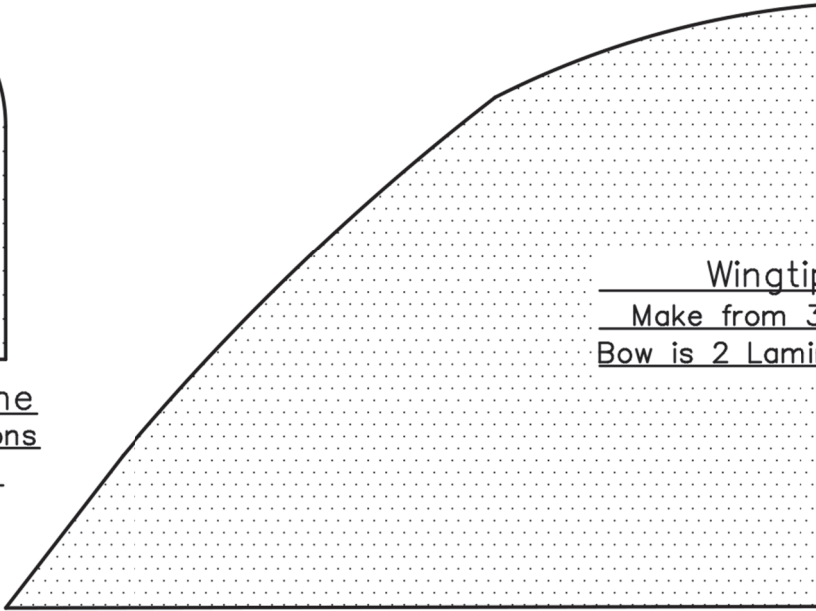

Wingtip
Make from 3
Bow is 2 Lami

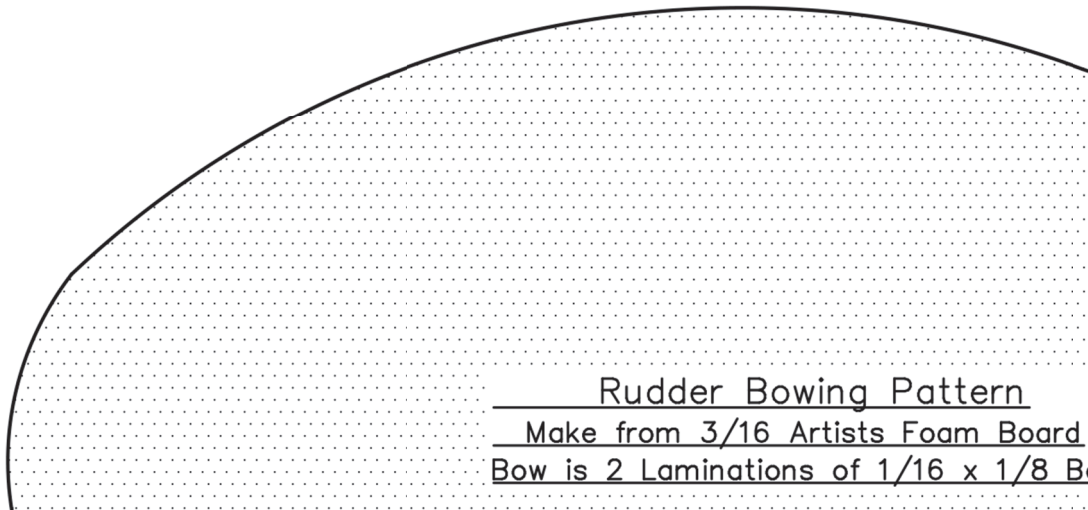

Rudder Bowing Pattern
Make from 3/16 Artists Foam Board
Bow is 2 Laminations of 1/16 x 1/8 B

Leading Edge (Outer) (4)

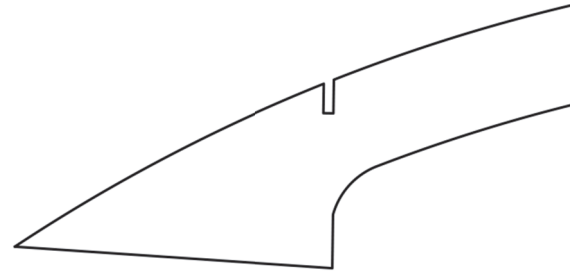
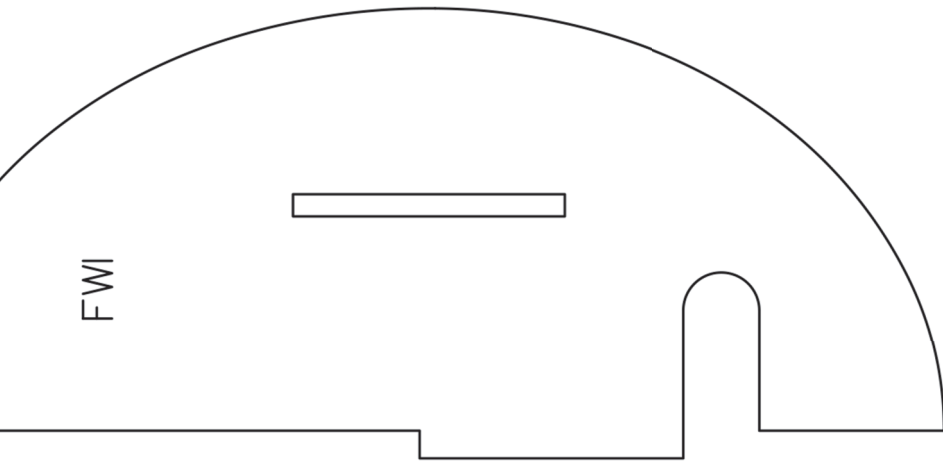

1/8 Balsa All Parts 1 ea.
Unless noted Otherwise

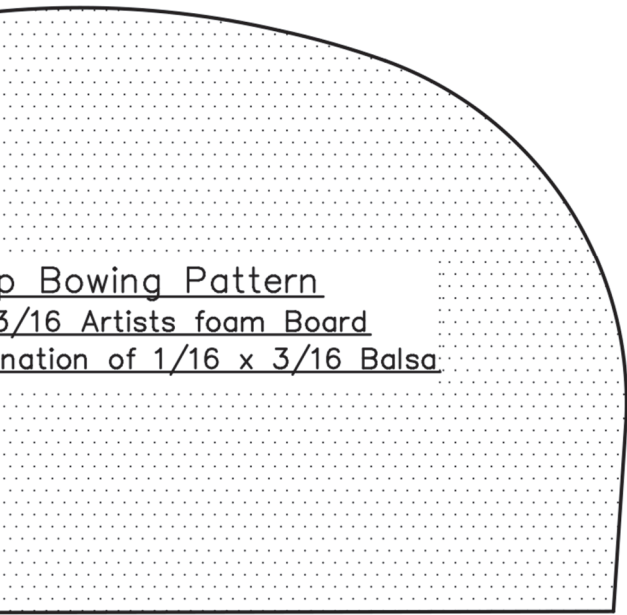

Bowling Pattern
3/16 Artists foam Board
Ink on 1/16 x 3/16 Balsa

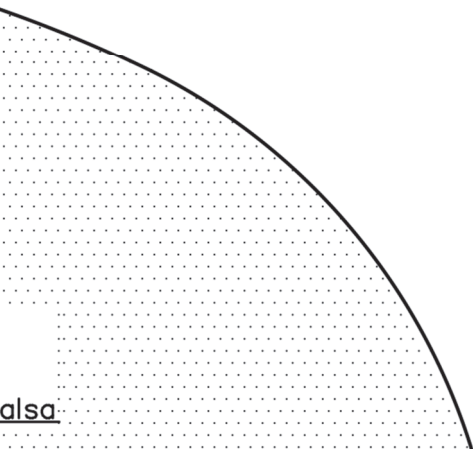

Balsa

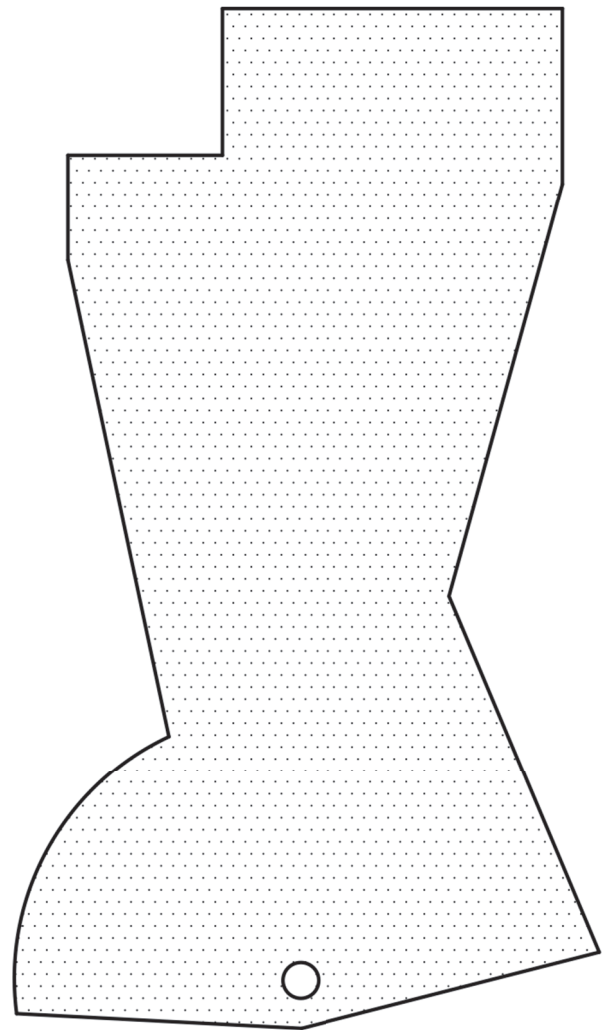

Landing Gear Door
Make from 3MM Depron 2

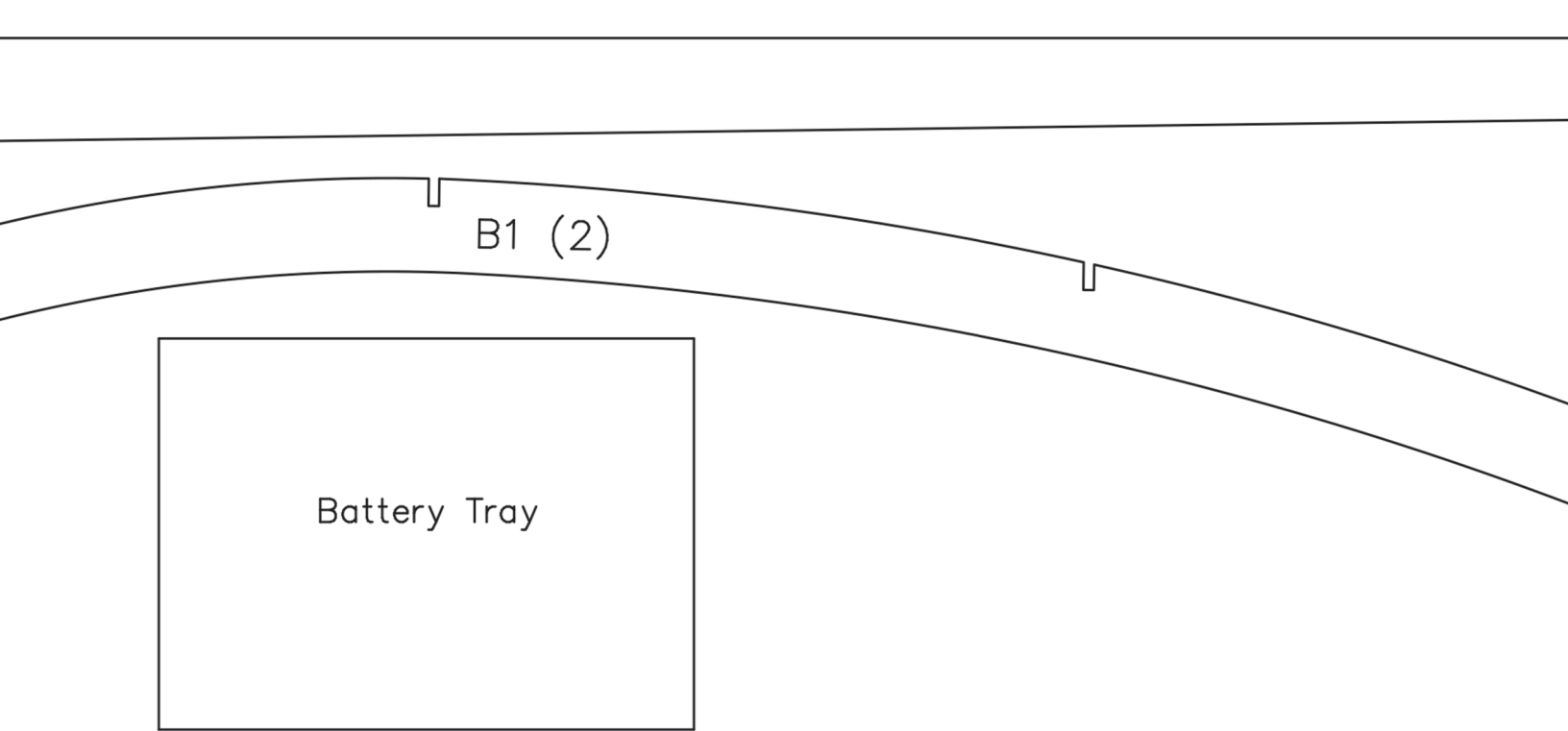

B1 (2)

Battery Tray

Additional Materials List

Wood:

Sheet Balsa if Laser Parts Package is Not Used:

5– $1/16$ x 4 x 36 Balsa

4– $1/8$ x 4 x 36 Balsa

1– $3/16$ x 3 x 36 Balsa

1– $1/32$ x 8 x 18 Birch Ply

1– $1/8$ x 4 x 8 1/2 Lite Ply

1– $1/32$ x 4 x 18 Balsa

2– $1/16$ Sq. x 36 Bass Wood

18– $1/16$ x $1/8$ x 36 Balsa

2– $1/16$ x $3/8$ x 36 Balsa

18– $3/32$ Sq. x 36 Balsa

2– $3/32$ x $1/4$ x 36 Balsa

8– $1/8$ Sq. x 36 Balsa

1– $1/8$ x $1/4$ x 12 Hard Balsa

2– $1/8$ x $3/8$ x 36 Balsa

1– $3/8$ x $1/2$ x 12 Bass Wood

1– $1/4$ x 6" Triangle Stock

1– $1/8$ x 6" Dowel

1– $3/16$ x 1" Dowel

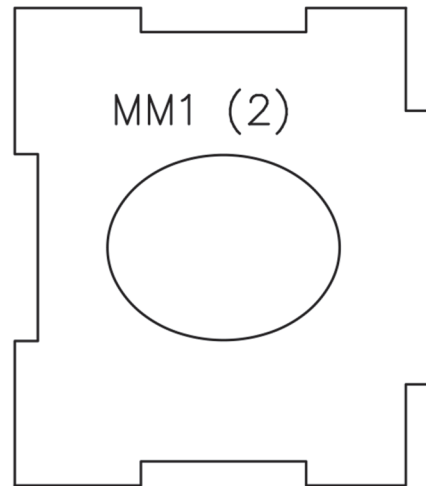
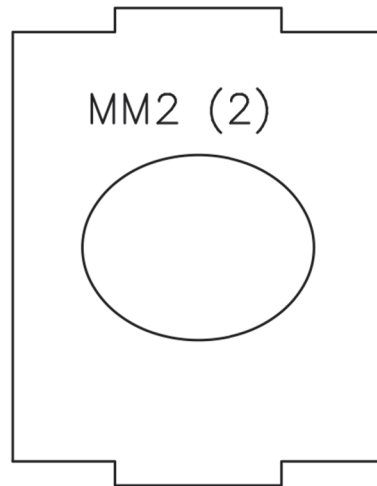
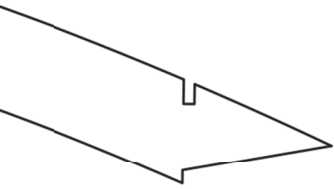

Miscellaneous:

- 1 Pair 2 1/2" Main Wheels
- 1- 1" Tail Wheel
- 3 ft.- Nylon Thread - Rudder Pull Cables
- 4- 3/32 Wheel Retainers
- 1- Manila File Folder
- 2- 8-32 Socket Head Nylon bolts
- 12- 3/16 Dia. x 1/16 Rare Earth Magnets
- 1- .008 x 8 x 18 Acetate
- 1- 3/16 x 10 x 12 Artists Foam Board
- 1- 3MM x 6 x 8 Depron Sheet
- 12- #2 Flat Washer
- 12- #2 x 3/8 Sheet Metal Screw

Power:

- 1- Suppo 2217/9T Outrunner Motor
- 1- 20 Amp ESC
- 1- APC 11-5.5E Propeller
- 1- 2000 2S Lipoly Battery

Guidance:

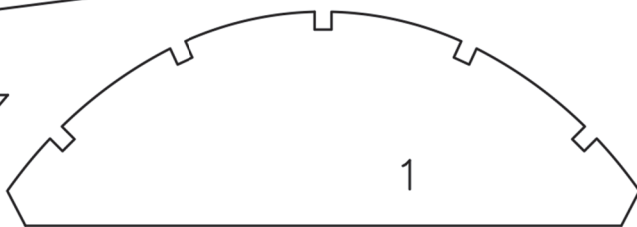
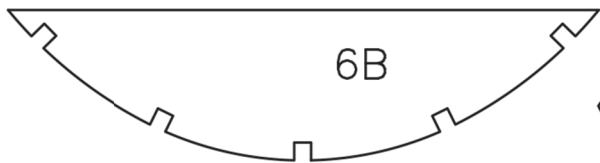

Builders Notes:

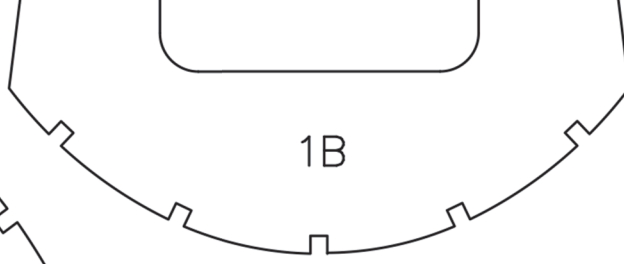
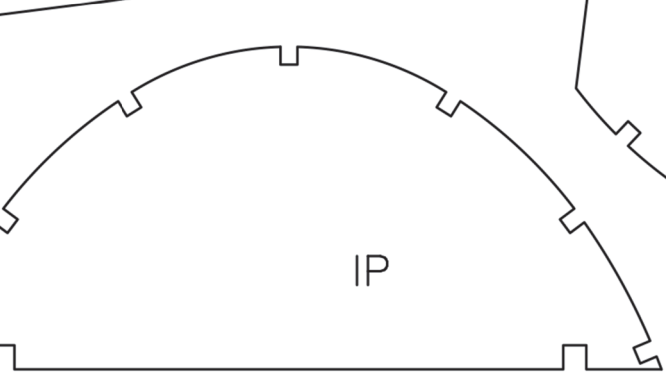

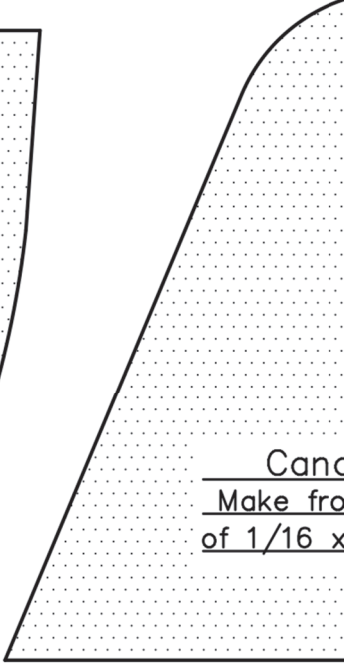
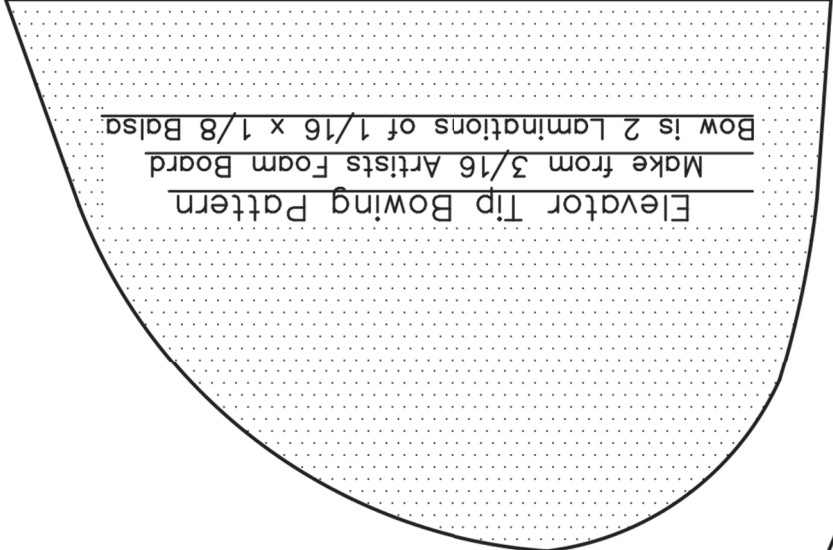

Bowing Patterns Make from 3/16 Artist

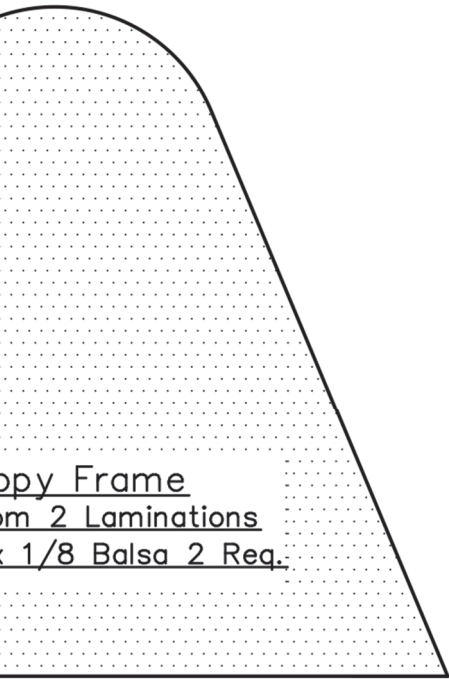
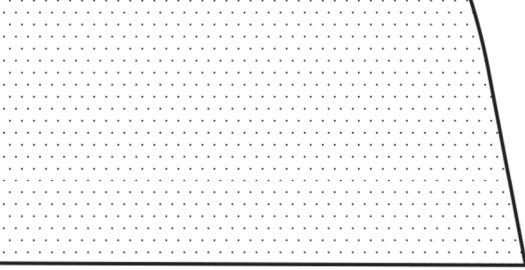

Copy Frame
from 2 Laminations
1/8 Balsa 2 Req.

s Foam Board

Req.

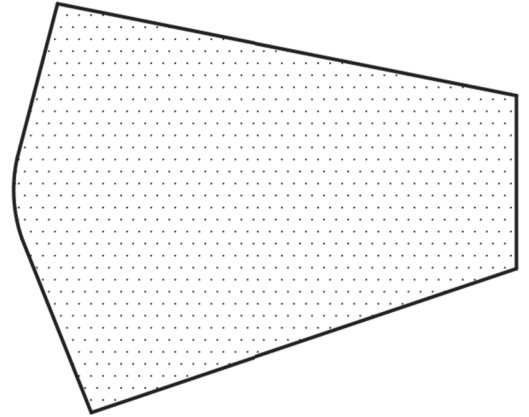

Wing LE Fairing
Make from File Folder Paper 2 Req.

- 1- 3/16 x 1" Dowel
- 1- Wood Toothpick

Wire:

- 1- .025 x 18 Steel Wire
- 1- .032 x 18 Steel Wire
- 1- .046 x 12 Steel Wire
- 1- .093 x 36 Steel Wire

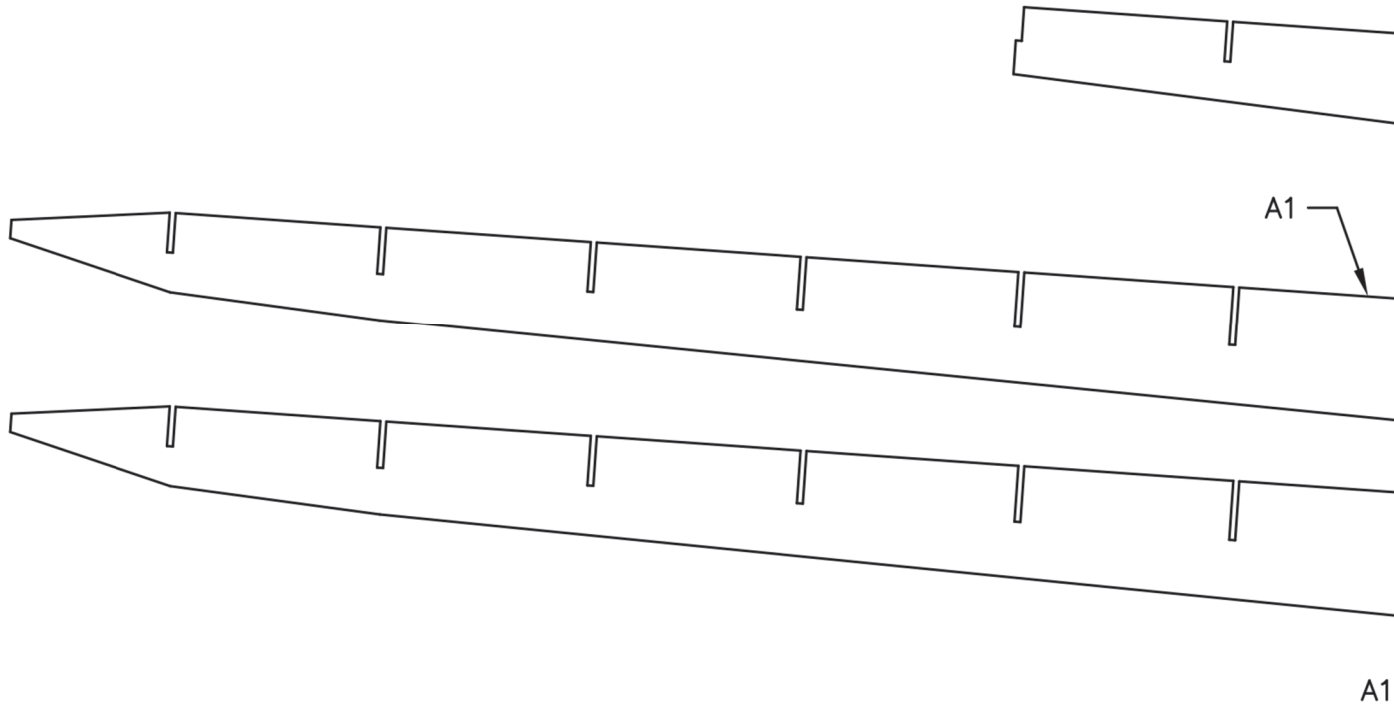

Guidance.

2- Suppo SP-60 Servos - Ailerons

2- Suppo SP-90 Servos - Rudder & Elevator

3- 6" Servo Extensions

1- 6" Y-Lead

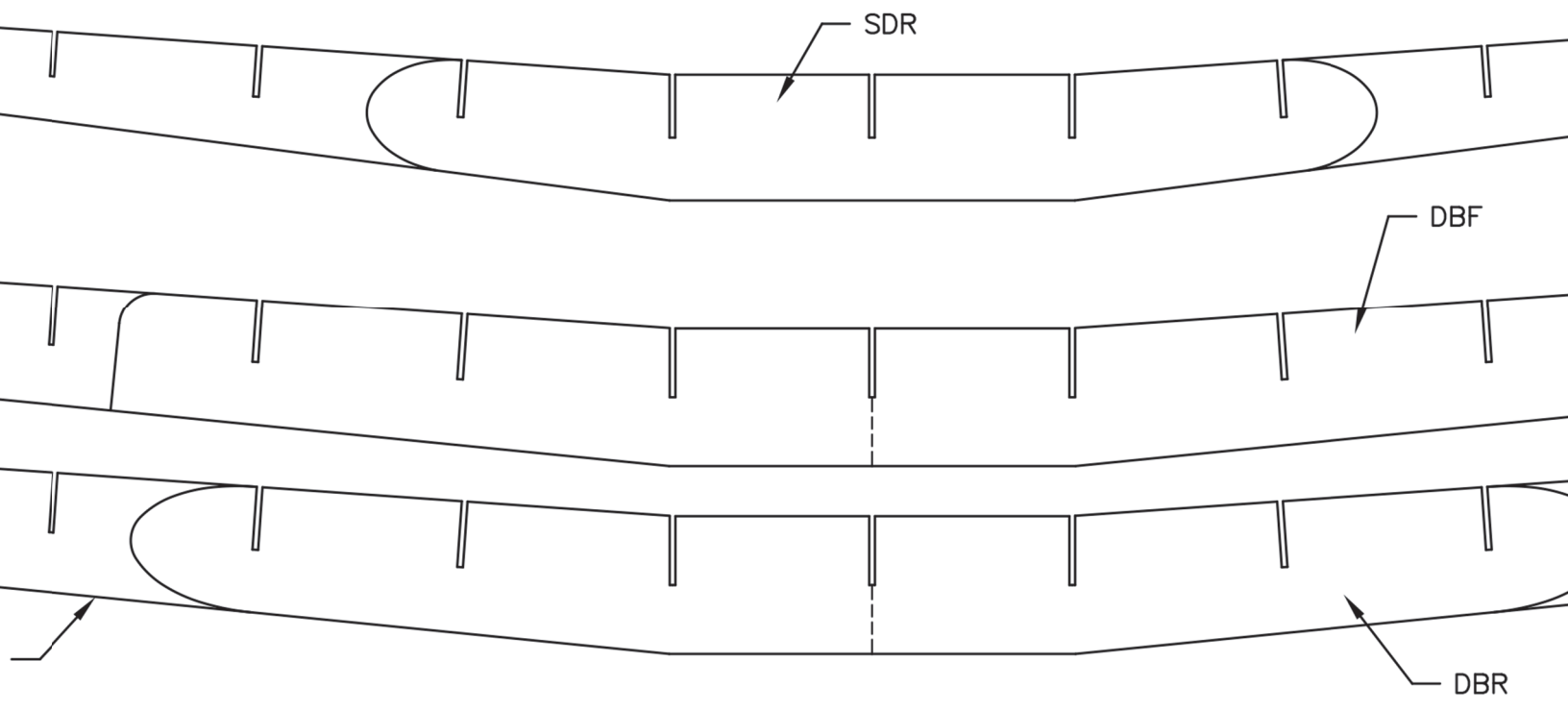

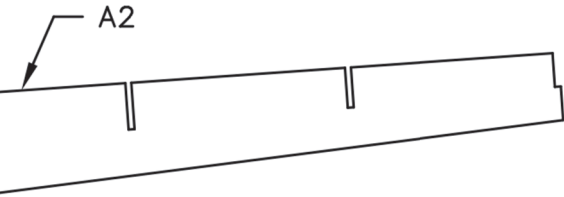

Spar Assembly Detail Drawings
Spars are Shown at 1/2 Scale

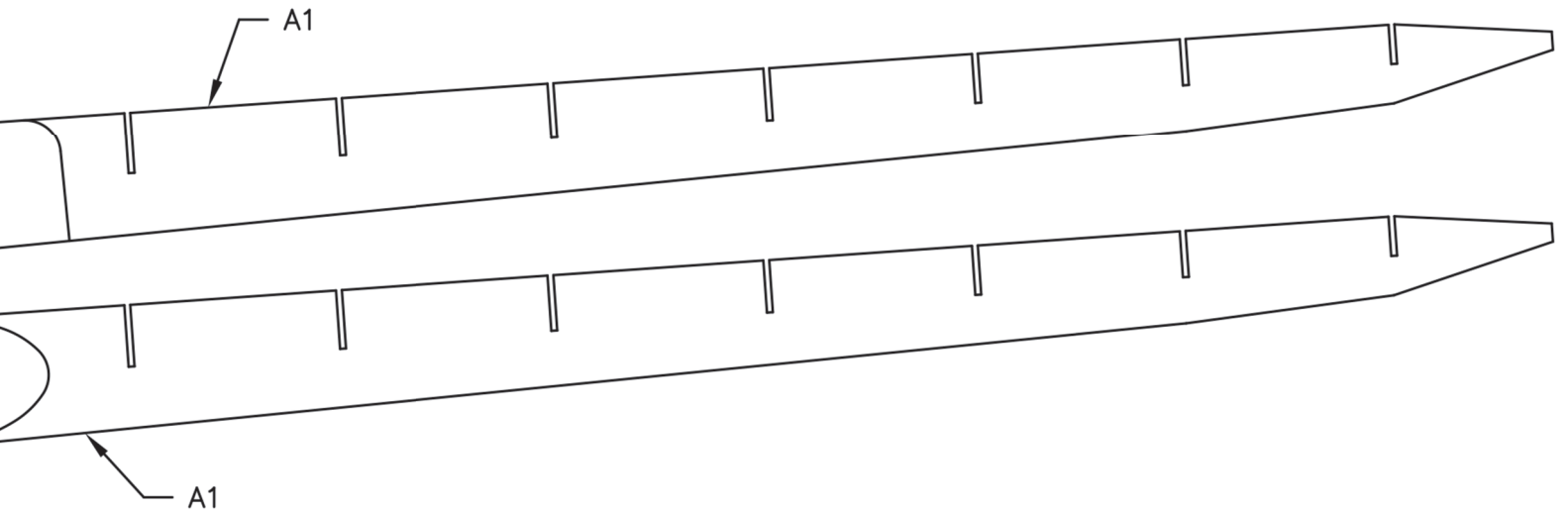

Curtiss SB2C Helldiver

Span: 48" Length: 37.7"

Wing Area: 396 Sq. In. Wt: 24.3 oz.

Designed by: Pat Tritle for
Model Aviation Magazine

Sheet 3 of 3

11-17-2018