

COWL RING

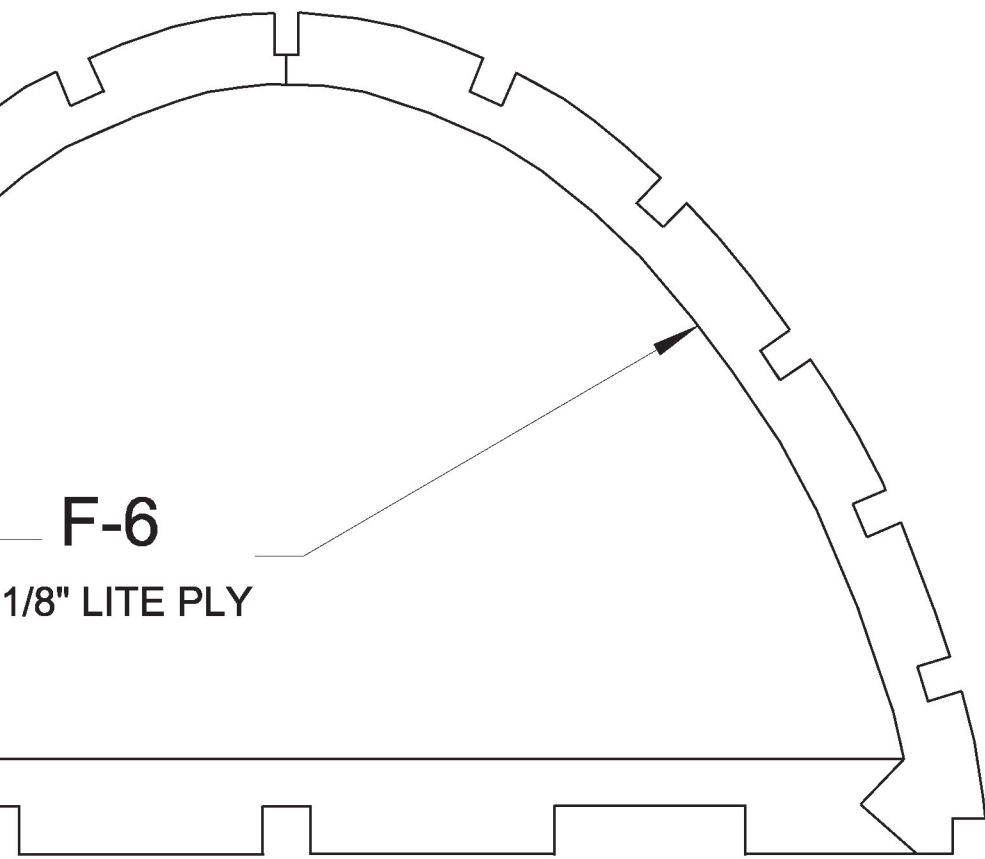

**F-6**

1/8" LITE PLY

**GUN COVERS- MADE FROM SCRAP BALSA**

FUSE IS BUILT  
"FUSE TOP VIEW"  
ADDED AFTER

FUSE STRINGER  
3/16" BALSA- C

CANOPY- MADE FROM  
CP PARTS AND THIN  
CLEAR PLASTIC

GC-1

GC-2

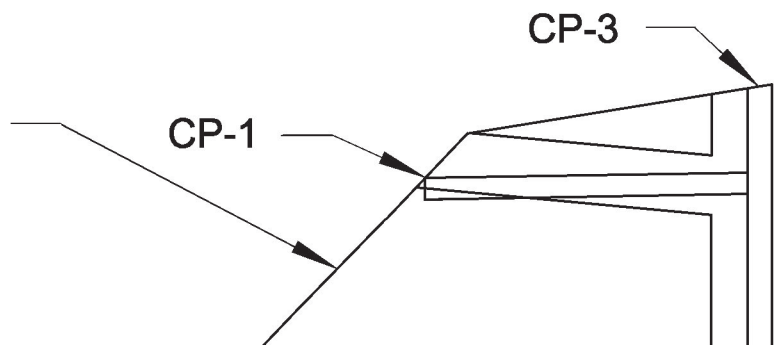

LT OVER THE BOARD ON THE  
VIEW" PLAN. BOTTOM FORMERS  
ER REMOVAL FROM BOARD

GERS ARE MEDIUM TO HARD  
OMITTED FOR CLARITY

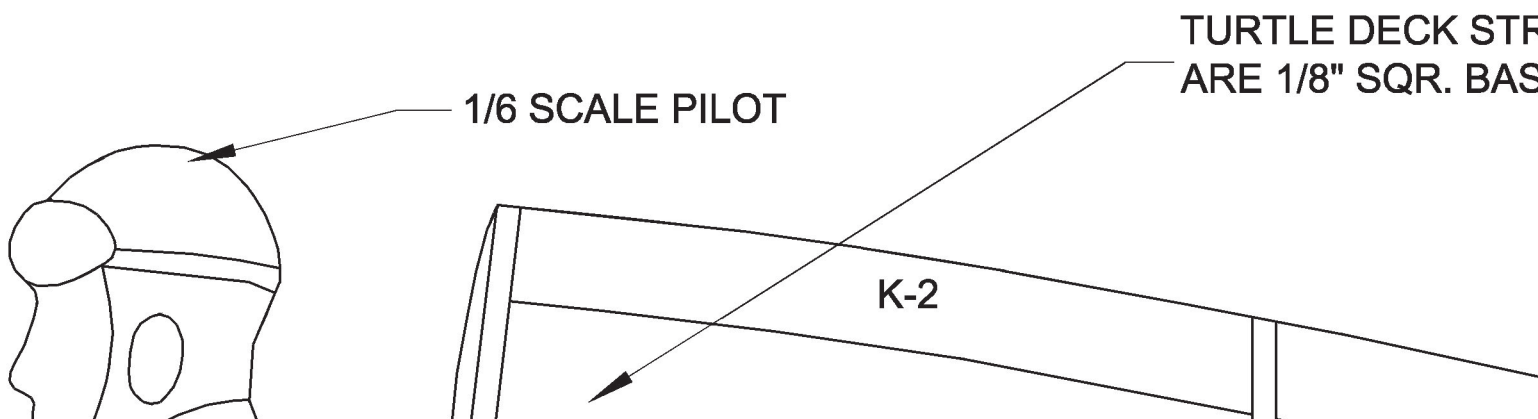

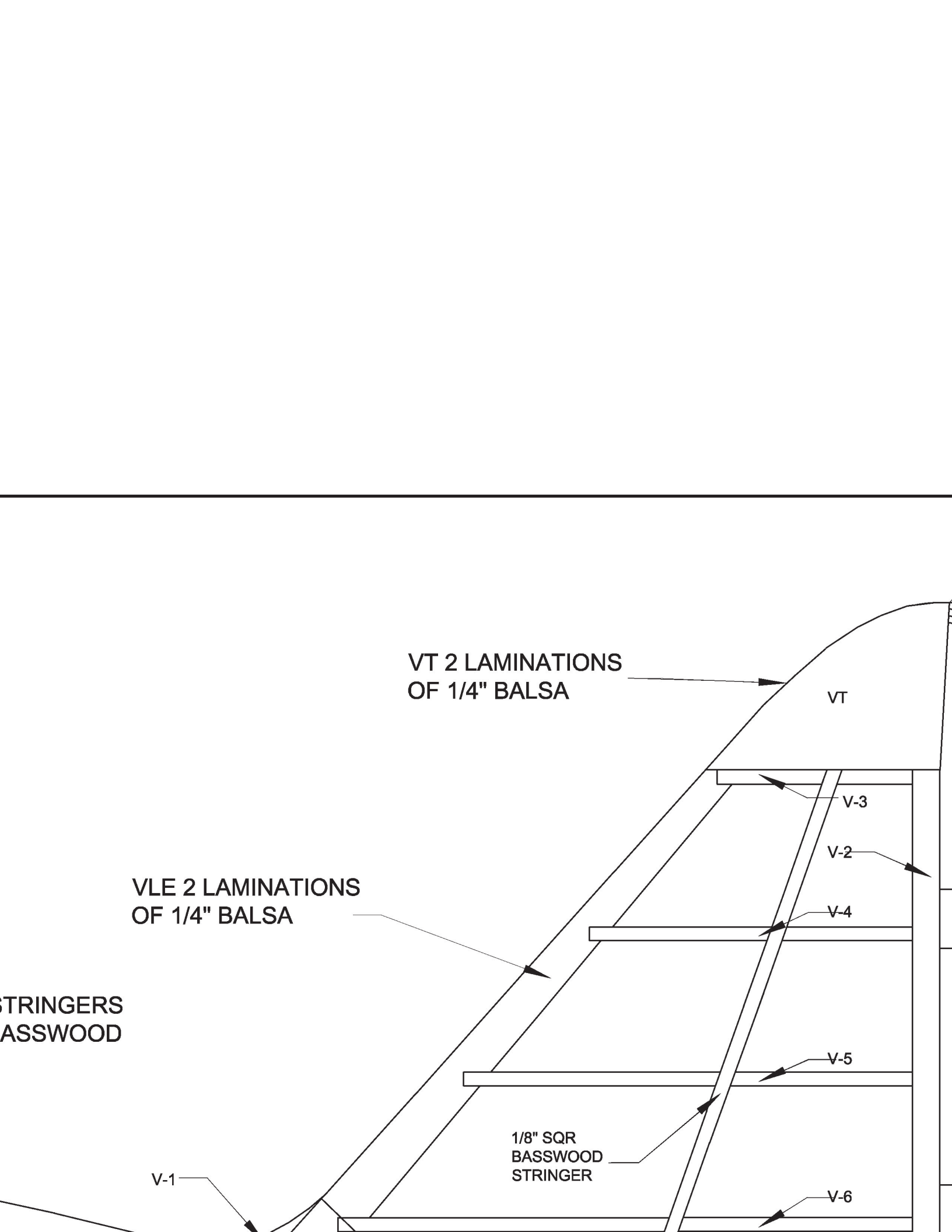

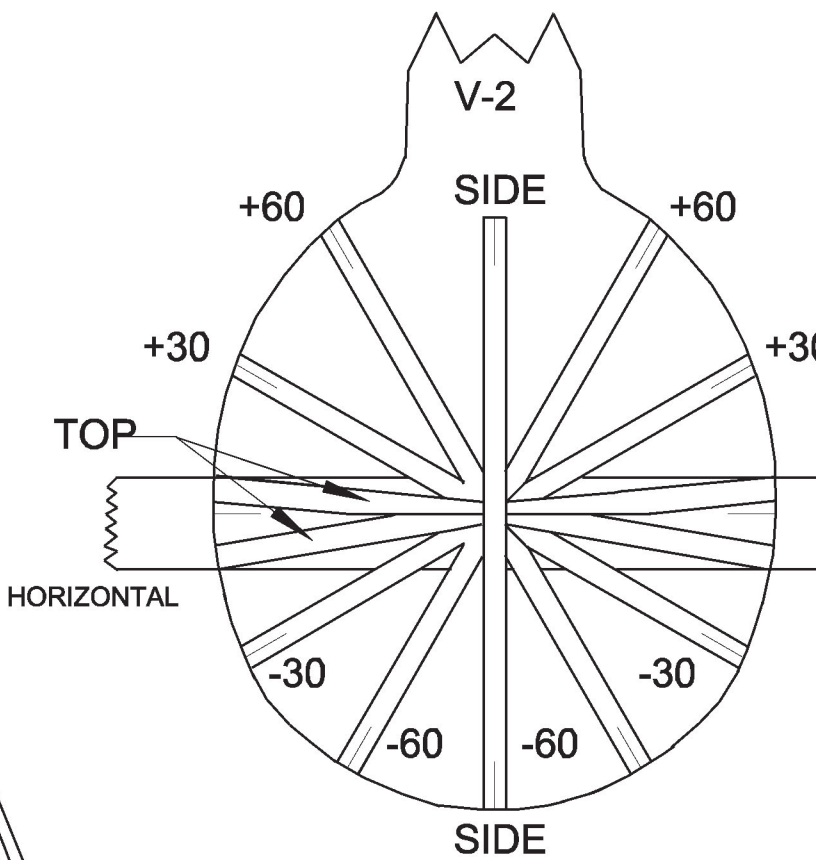
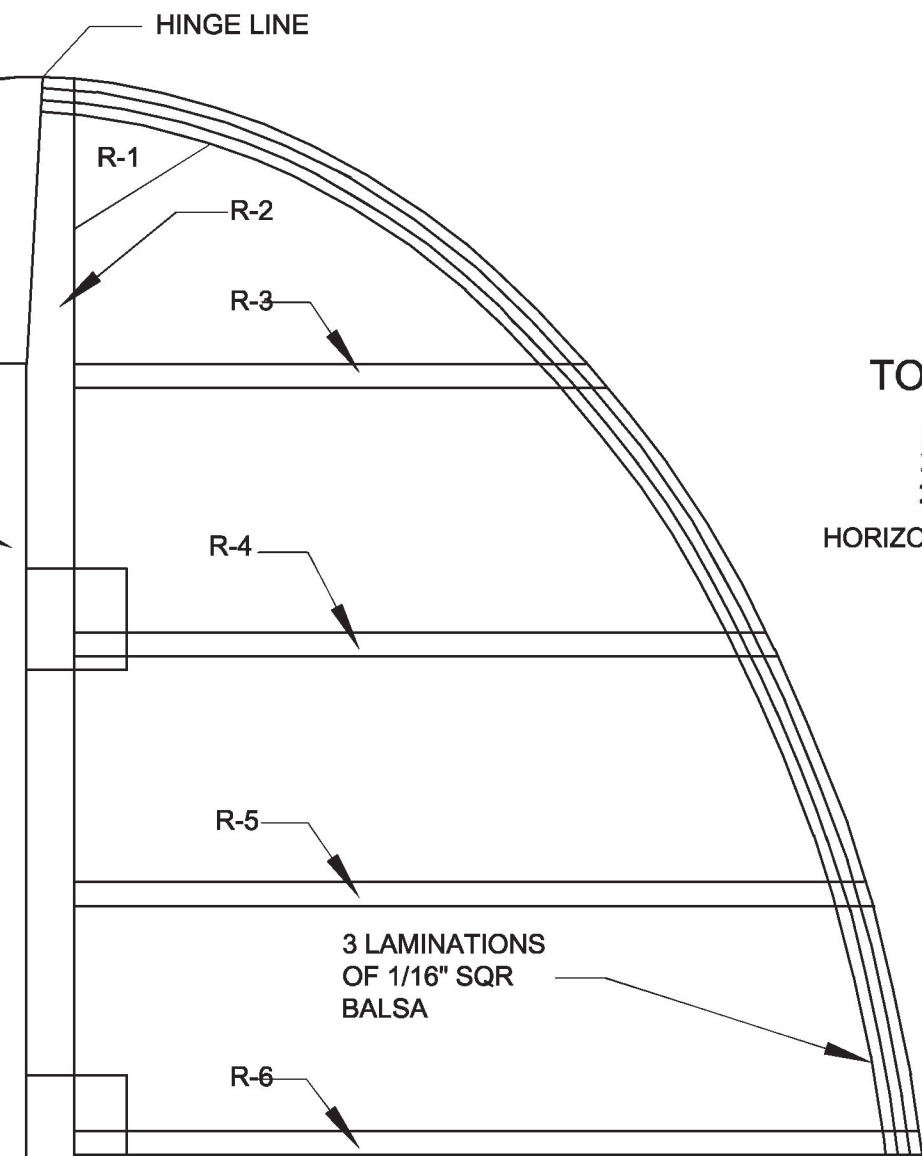

TAIL WHEEL DETAIL  
OF V-2- LOOKING

+30

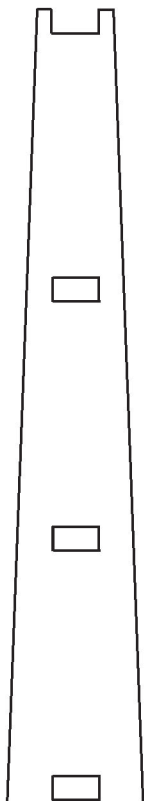
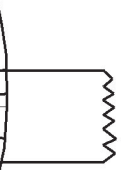

DETAIL  
ING



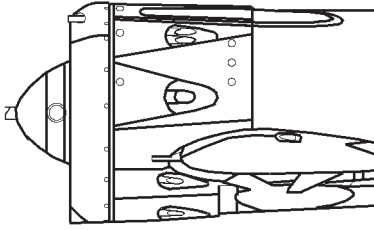
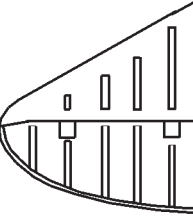

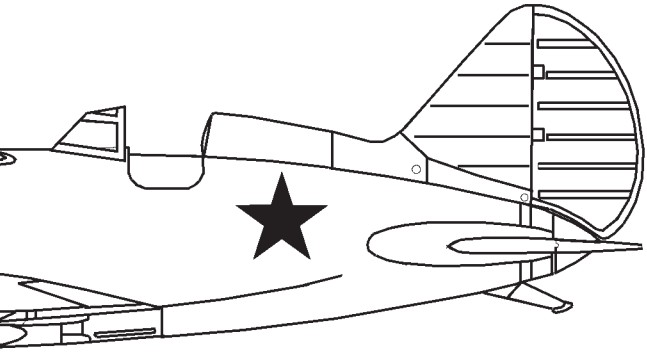
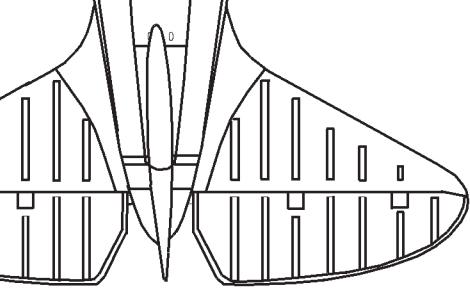

COWL RING  
CR-1 TO CR-4

**BUILDING  
BOARD  
LINE**

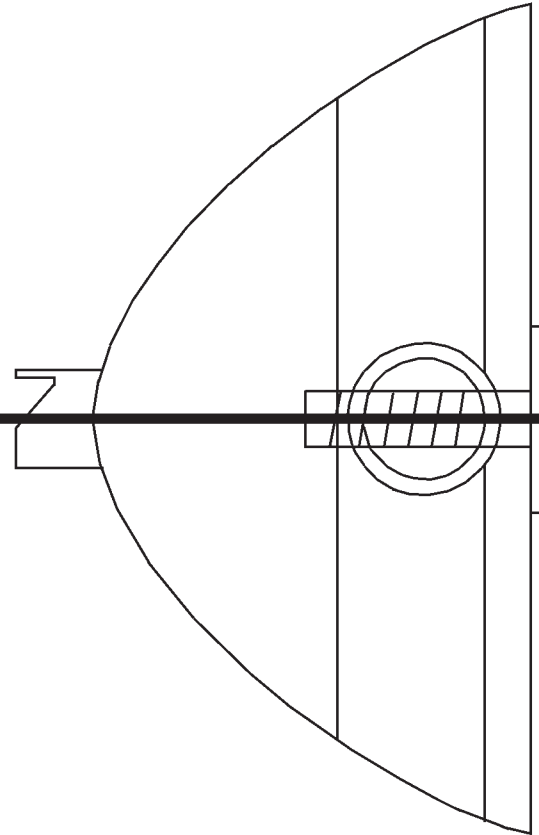

1/2" TRIANGLE  
STOCK

COWL SEPARATION  
LINE

SCOOP FROM  
SCRAP BALS

COWL SHEETED  
WITH 1/16" BALS  
SEE BELLY PAN

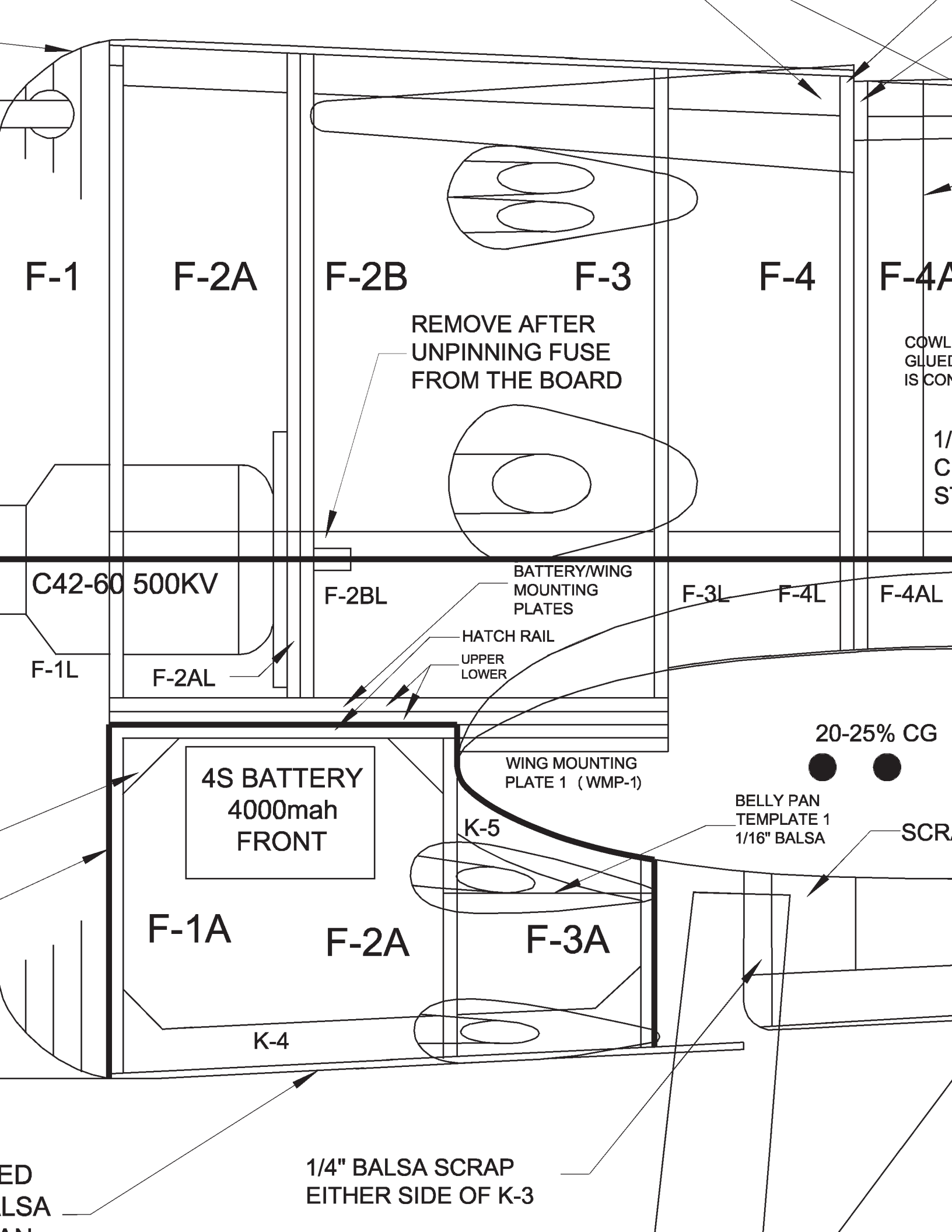

F-1

F-2A

F-2B

F-3

F-4

F-4A

REMOVE AFTER  
UNPINNING FUSE  
FROM THE BOARD

COWL  
GLUED  
IS COM

1/  
C  
S

C42-60 500KV

F-2BL

BATTERY/WING  
MOUNTING  
PLATES

F-3L

F-4L

F-4AL

F-1L

F-2AL

HATCH RAIL

UPPER  
LOWER

4S BATTERY  
4000mah  
FRONT

WING MOUNTING  
PLATE 1 (WMP-1)

20-25% CG

BELLY PAN  
TEMPLATE 1  
1/16" BALSA

SCR

F-1A

F-2A

F-3A

K-5

K-4

ED  
LSA  
AN

1/4" BALSA SCRAP  
EITHER SIDE OF K-3

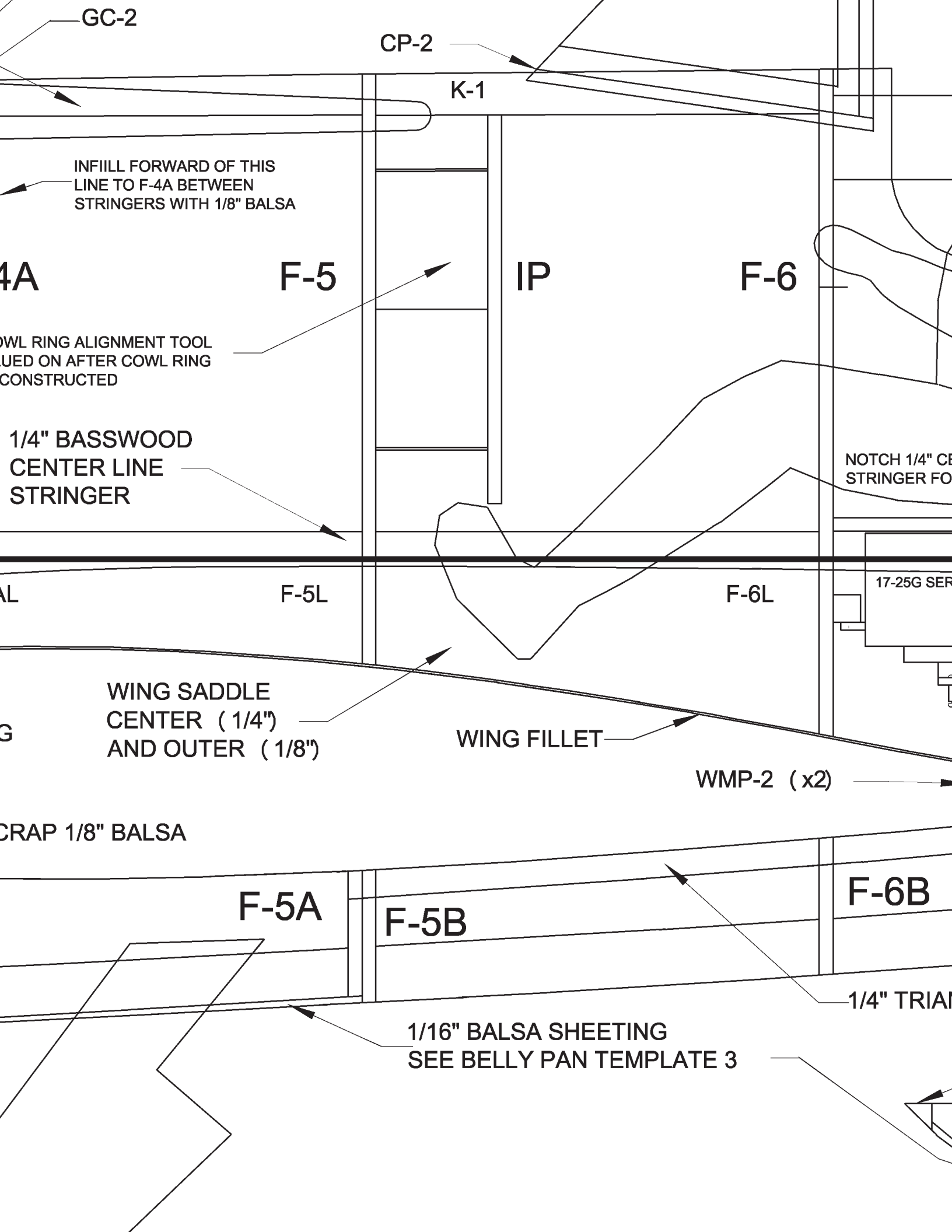

GC-2

CP-2

K-1

INFIILL FORWARD OF THIS LINE TO F-4A BETWEEN STRINGERS WITH 1/8" BALSA

F-4A

F-5

IP

F-6

COWL RING ALIGNMENT TOOL USED ON AFTER COWL RING CONSTRUCTED

1/4" BASSWOOD CENTER LINE STRINGER

NOTCH 1/4" CENTER LINE STRINGER FOR

F-5L

F-5L

F-6L

17-25G SER

WING SADDLE CENTER (1/4") AND OUTER (1/8")

WING FILLET

WMP-2 (x2)

CRAP 1/8" BALSA

F-5A

F-5B

F-6B

1/16" BALSA SHEETING SEE BELLY PAN TEMPLATE 3

1/4" TRIANG

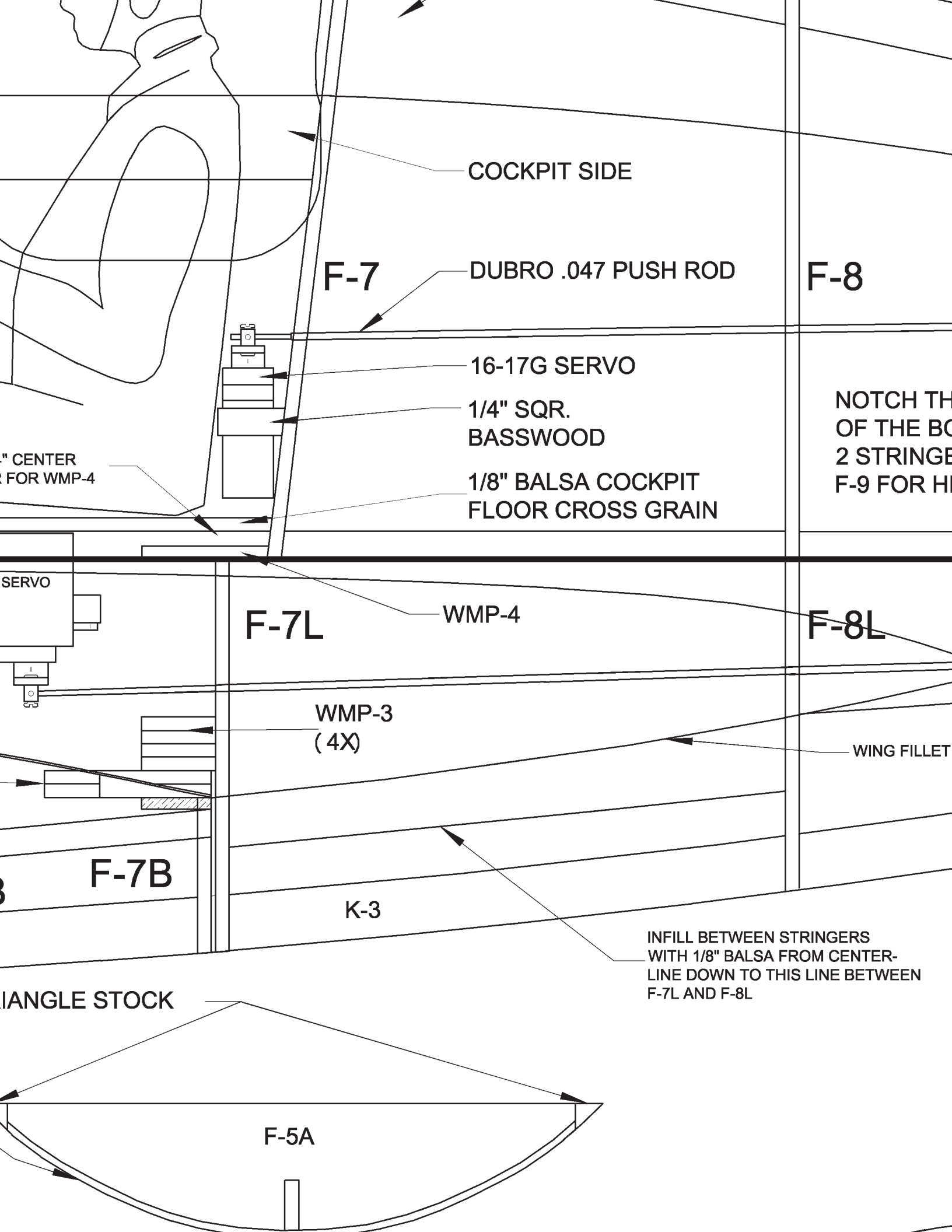

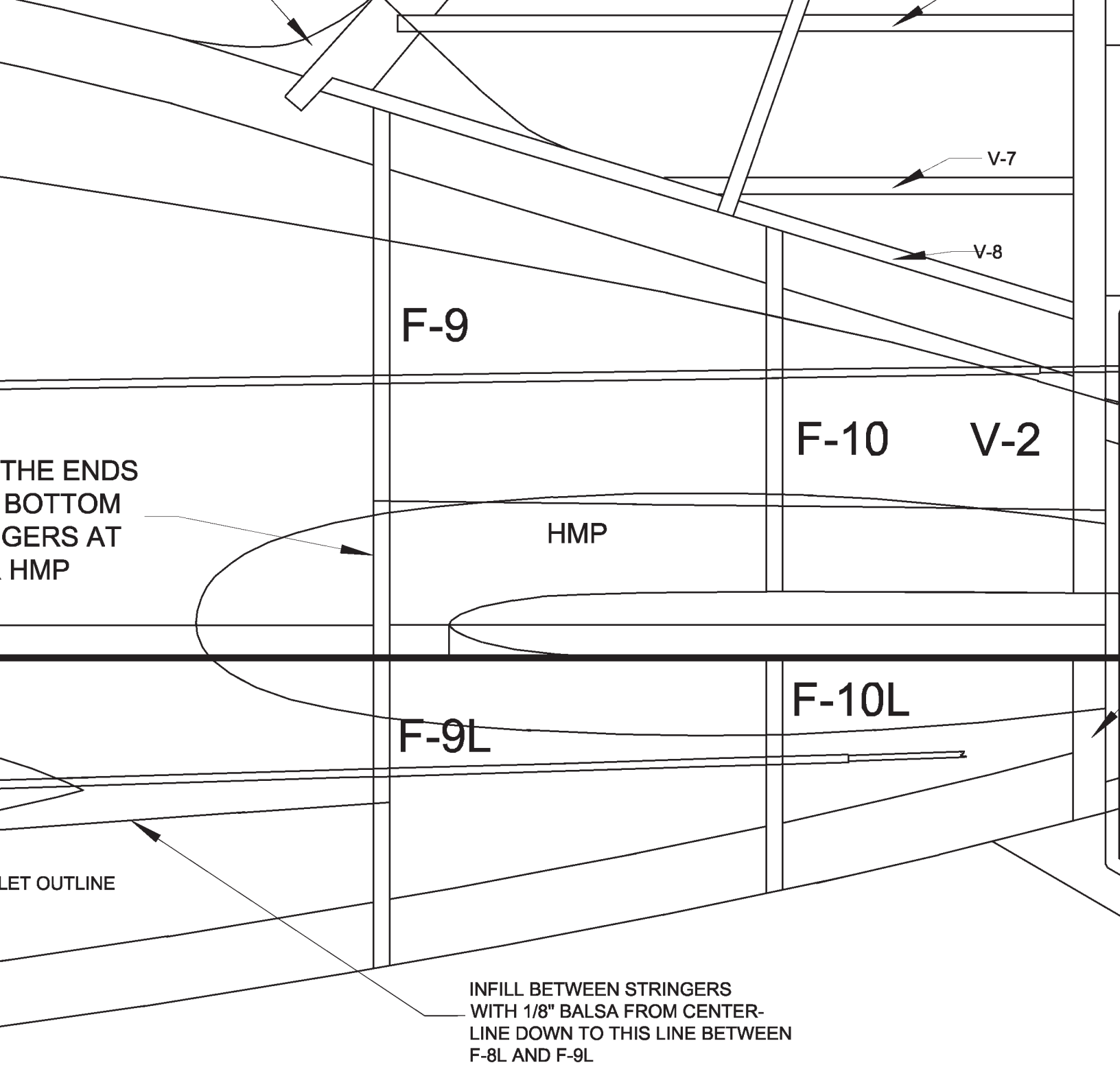

**\*HORIZONTAL IS BUILT  
BEFORE FUSE  
IS CONSTRUCTED**

OF V-2- LOOKING FORWARD

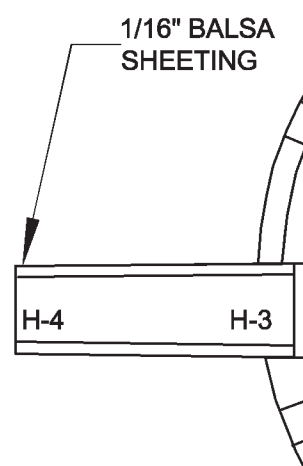
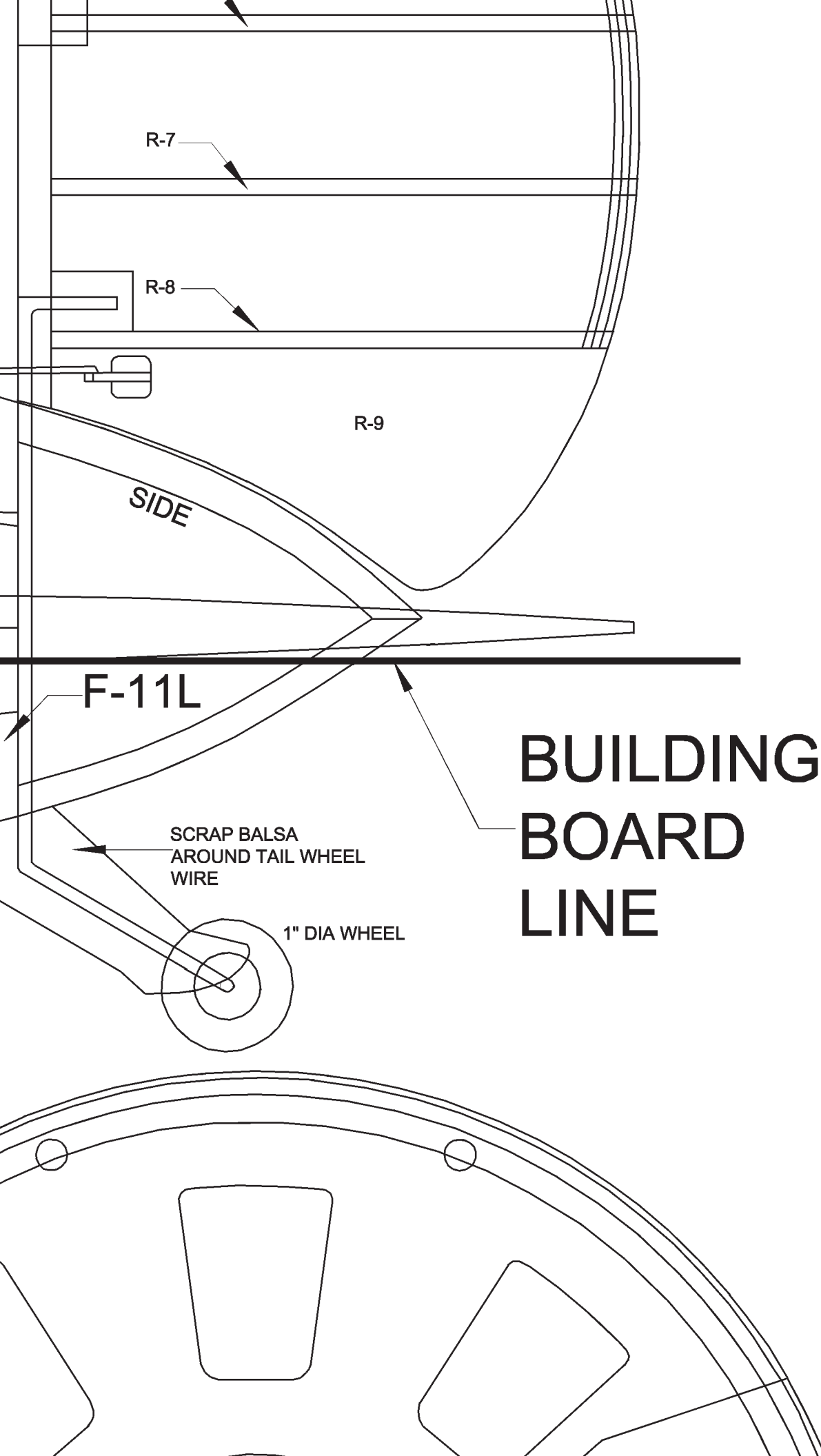

ING

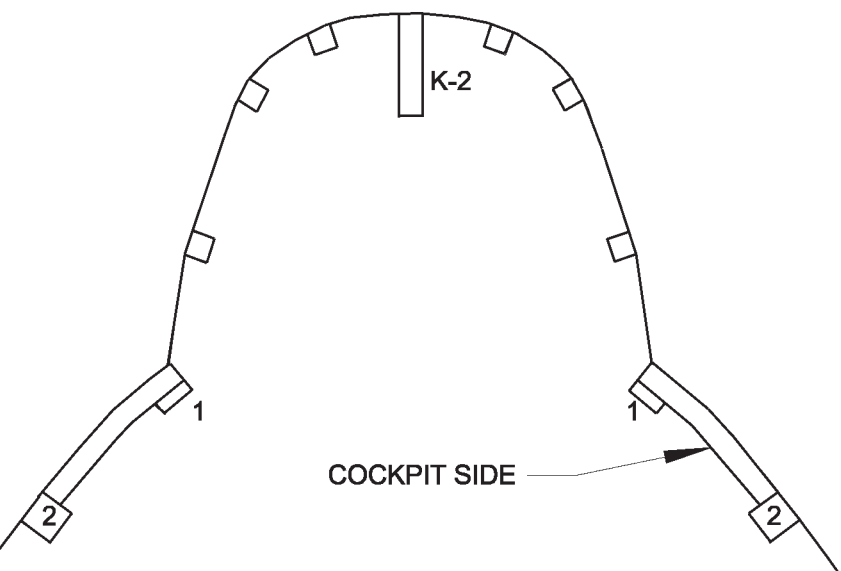
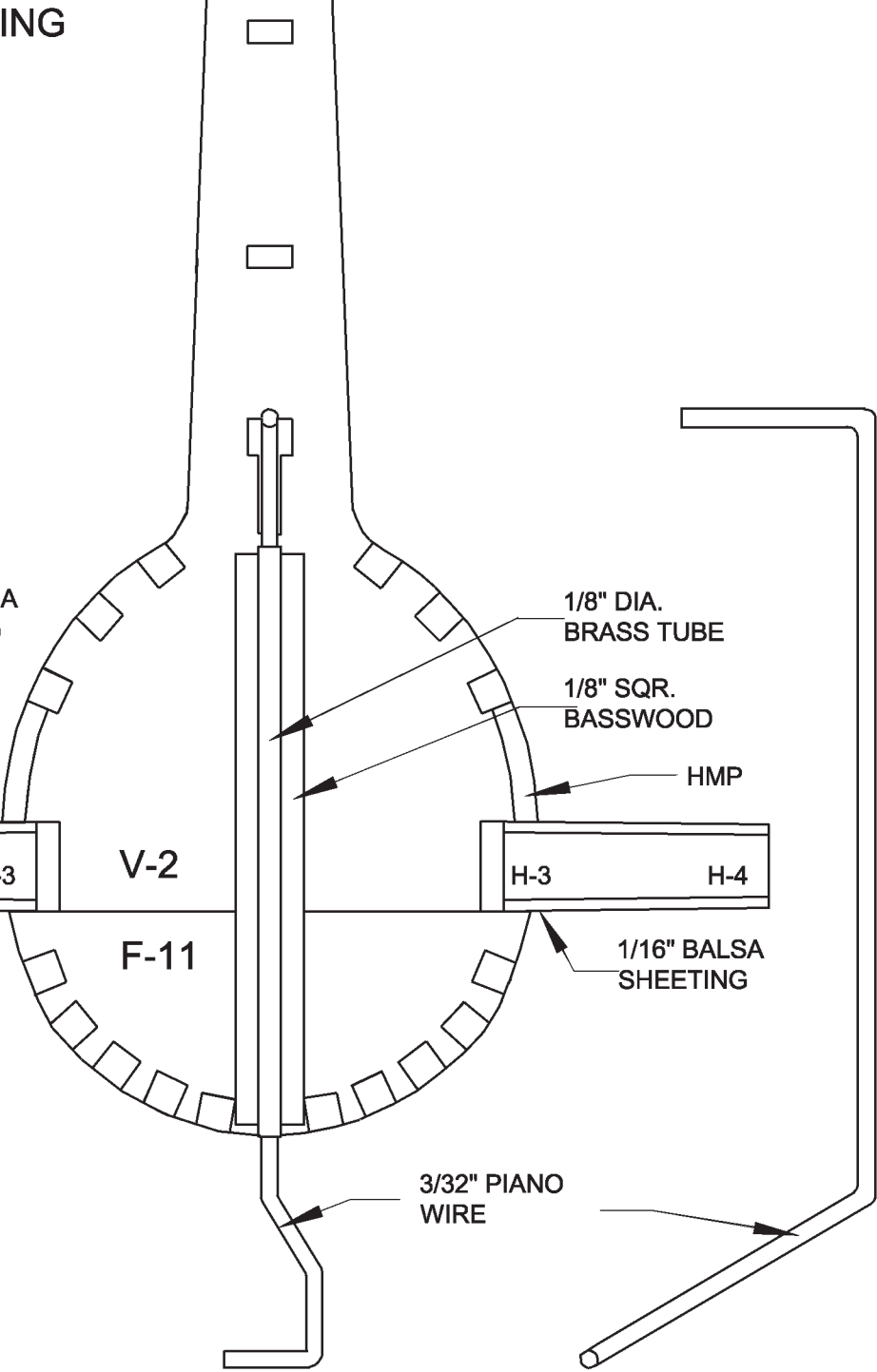



# 1-16 RATA

DESIGNED BY D

60" WINGSPAN

4-6 POUNDS

CHANNELS: 5

MOTOR: POWER

ALL RIGHTS RES

PLAN 1 OF 4

DEREK MICKO

Copyright 2018  and **ModelAviation**  
ACADEMY OF MODEL AERONAUTICS  
*Bringing Modelers Together*

Copying for resale of this drawing without  
the written approval or consent of AMA  
is expressly prohibited.

R 46 ELECTRIC  
RESERVED

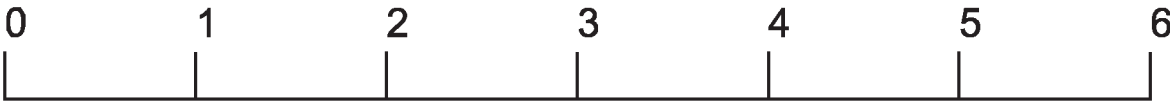

LSA  
AN

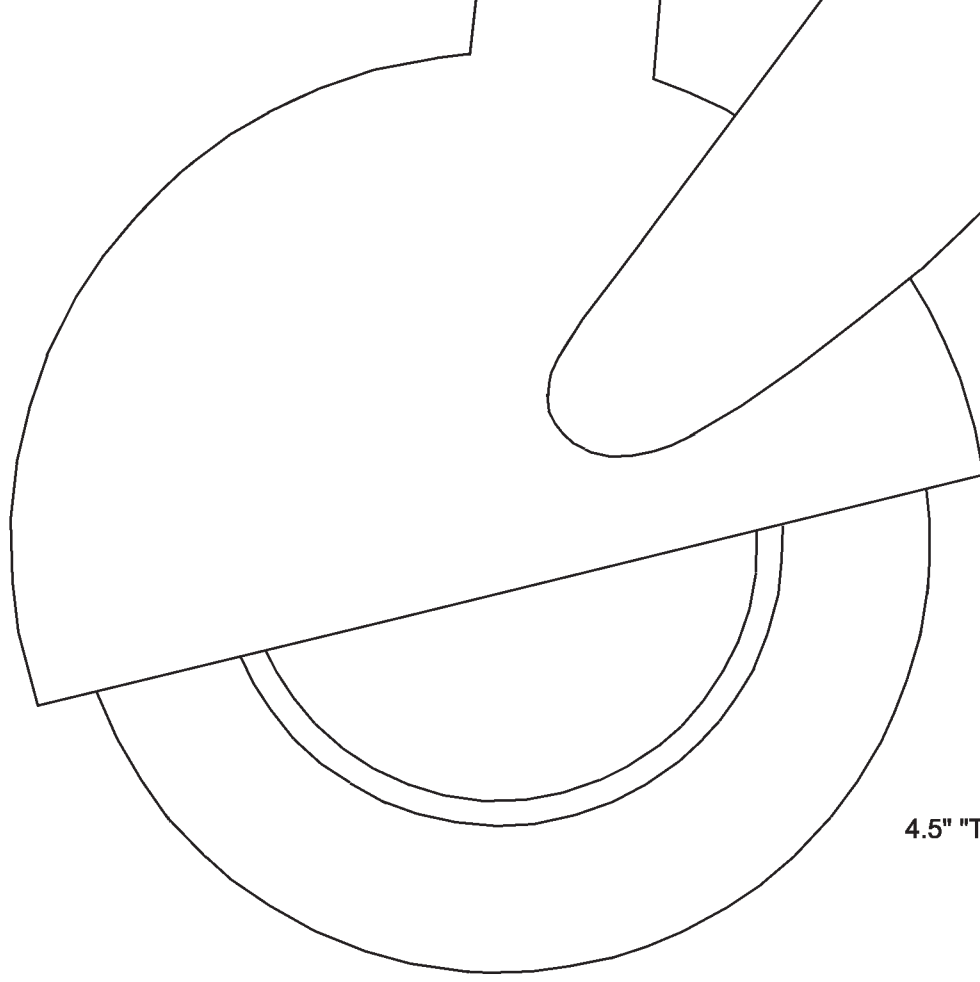

4.5" T



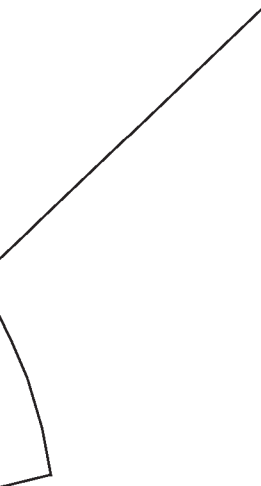

5" "THIN" WHEEL

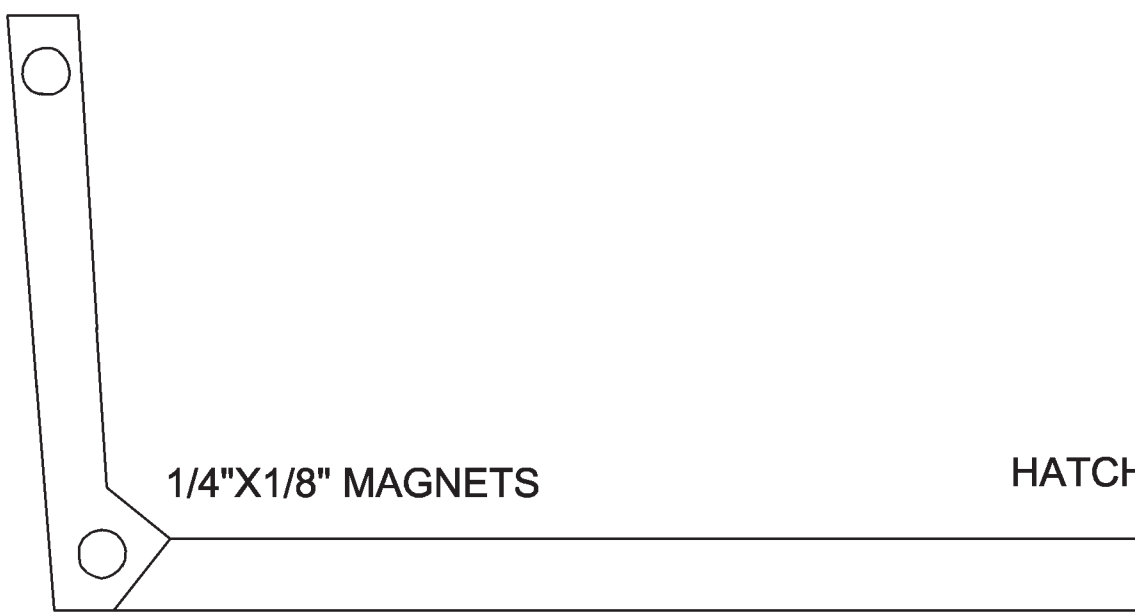

1/4"X1/8" MAGNETS

HATCH



CH RAIL DETAIL

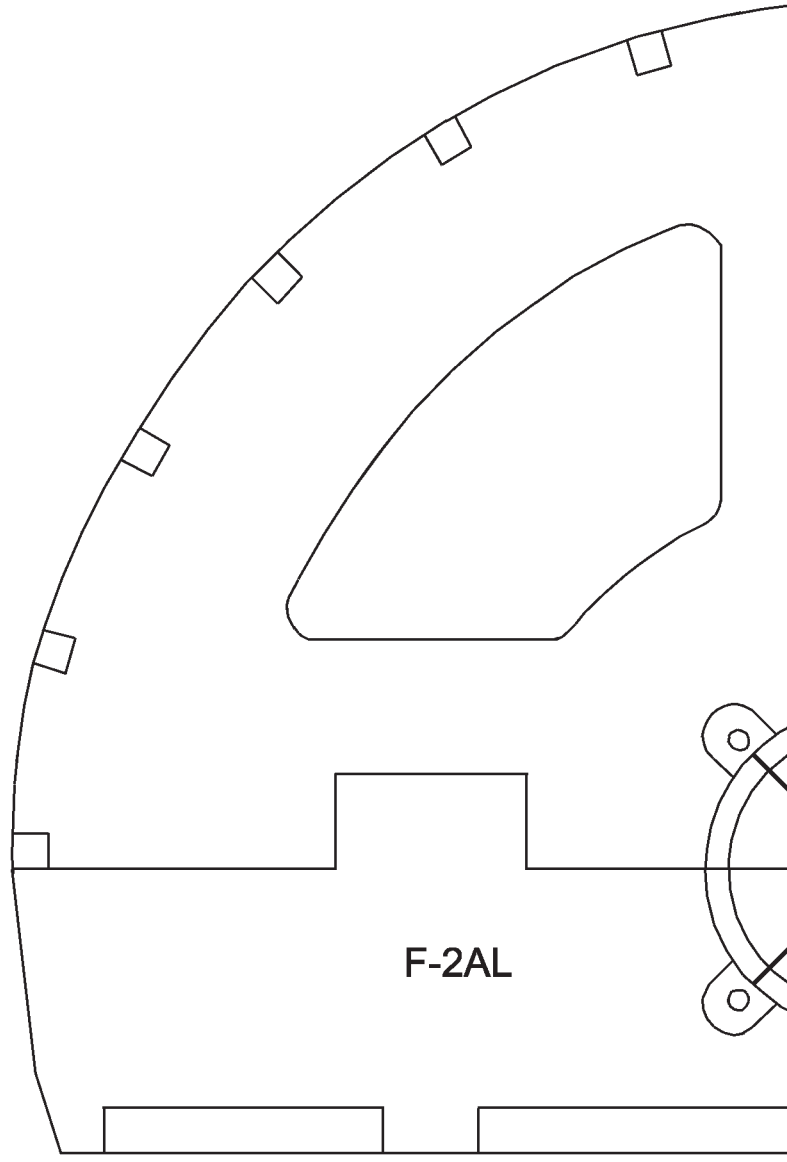
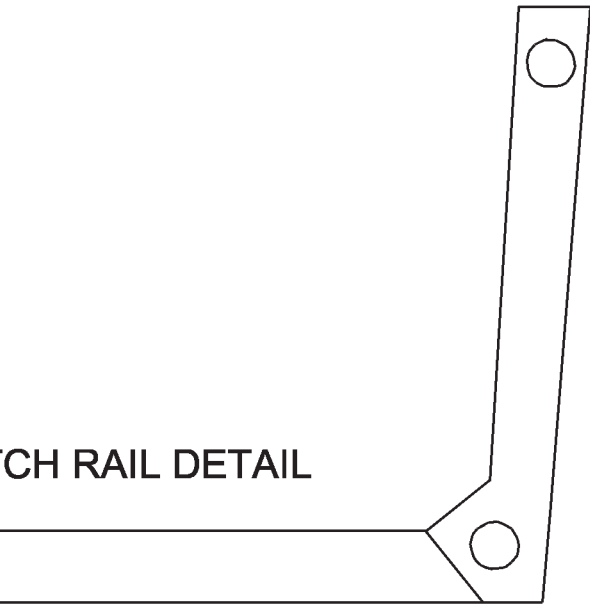

F-2AL

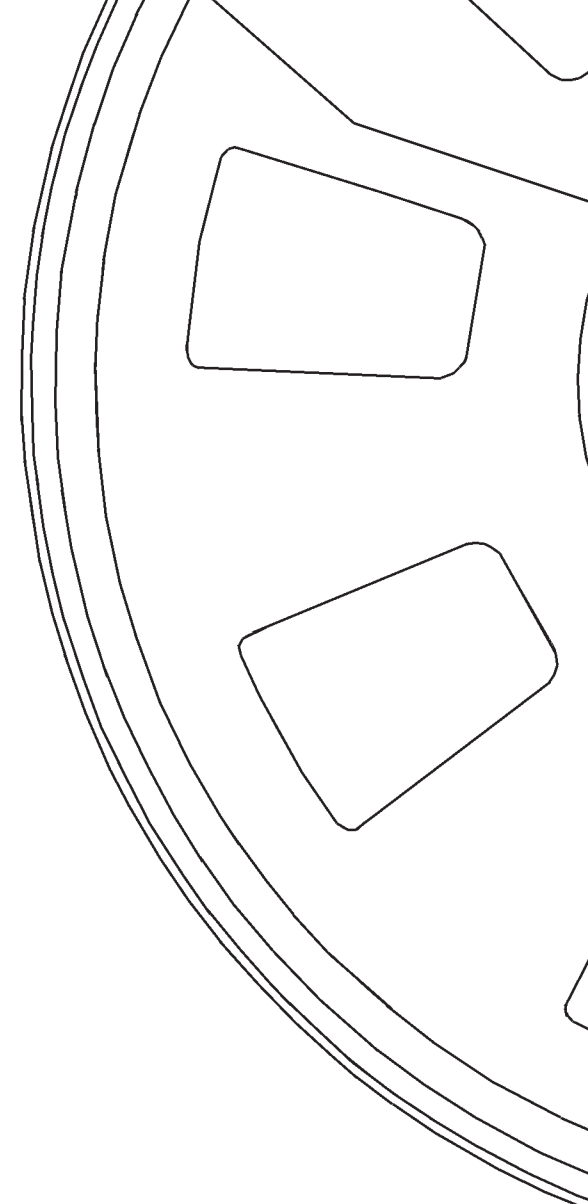
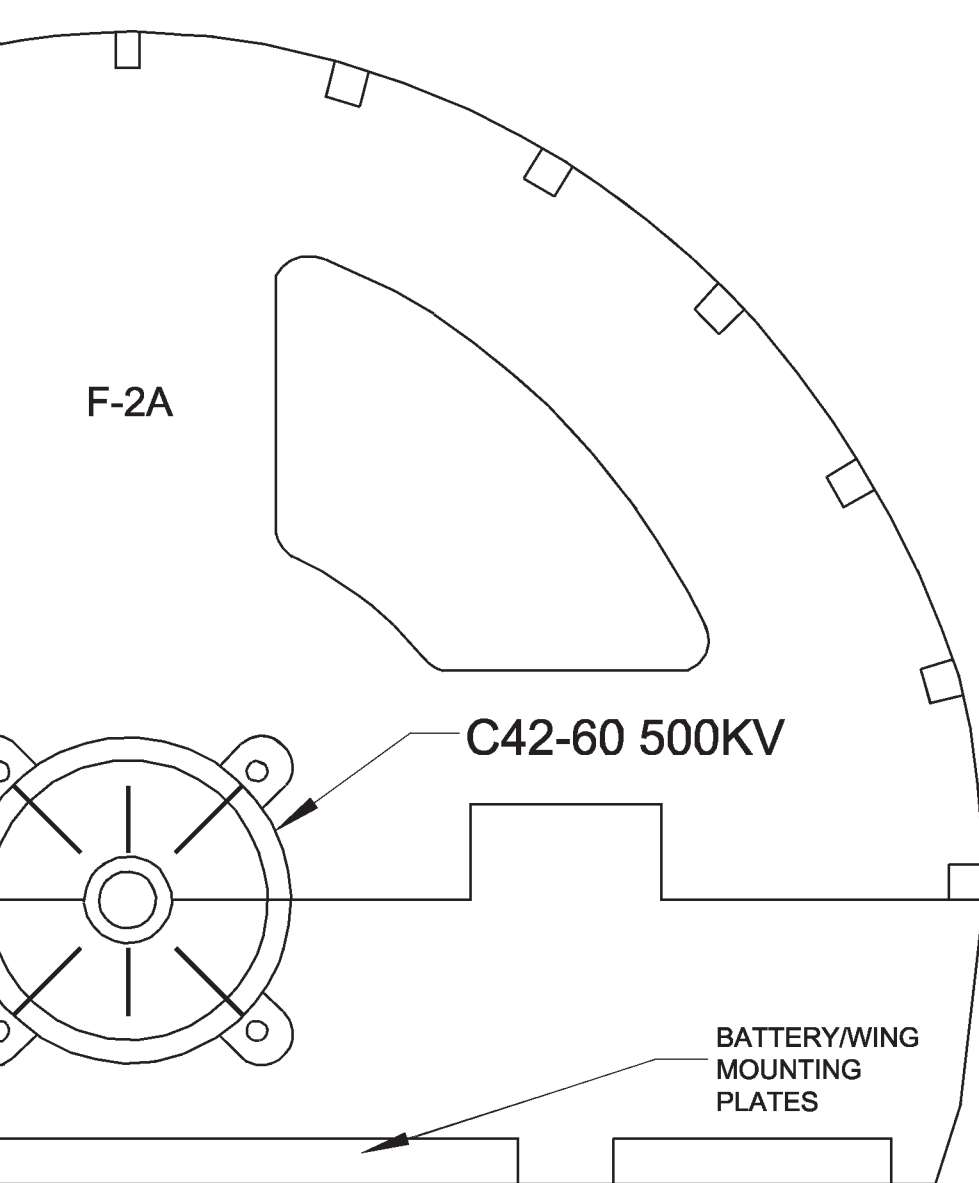

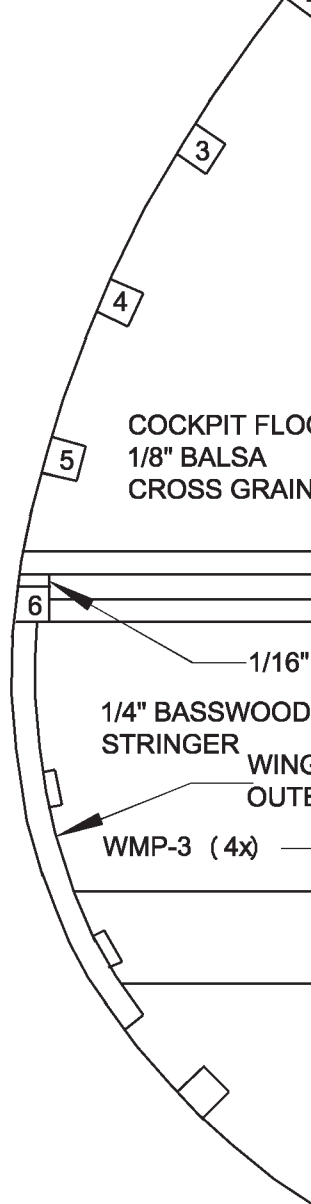
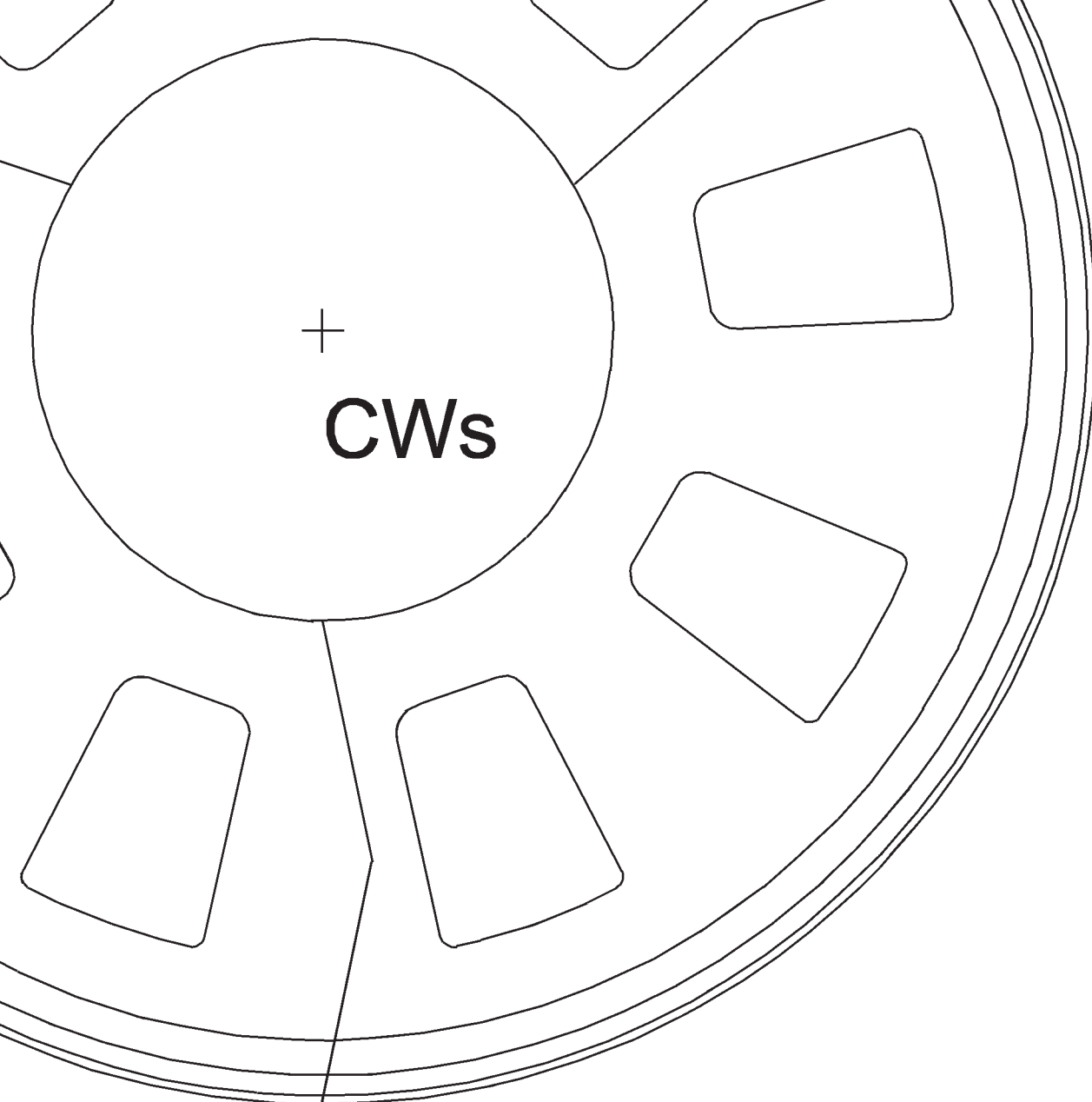

# F-7 DETAIL LOOKING AFT

