

2 OF EA

1/8

ACH NEEDED

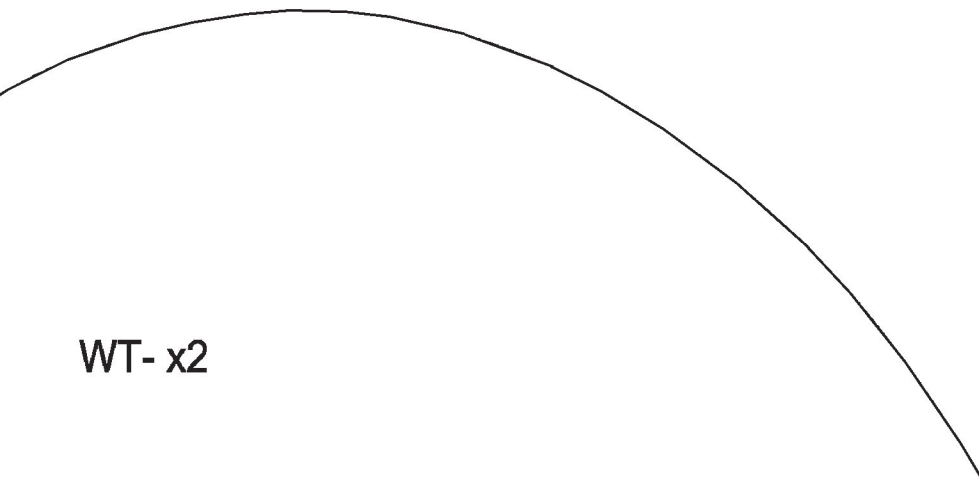

WT- x2

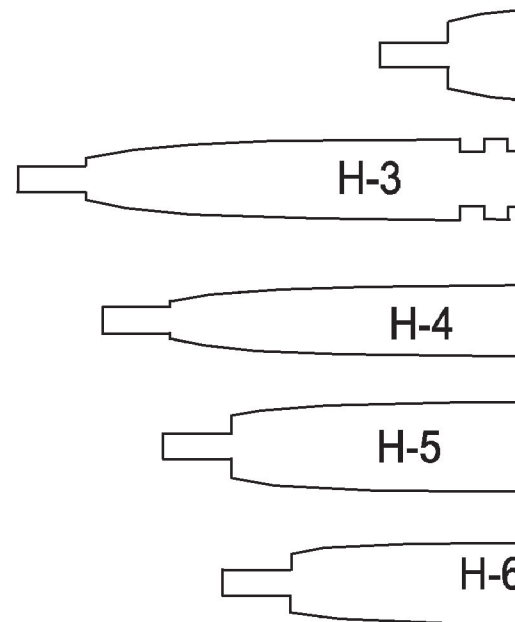

B BALSAS

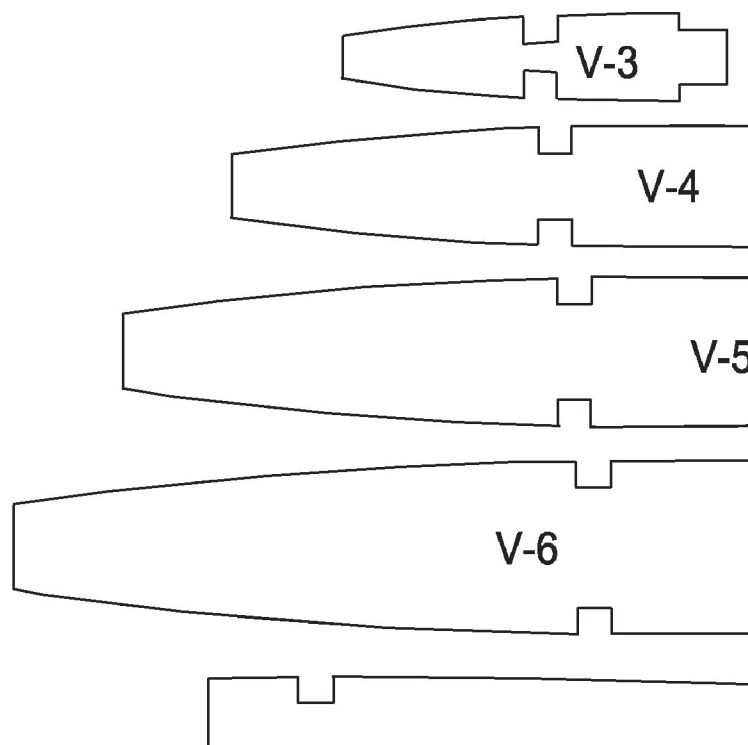
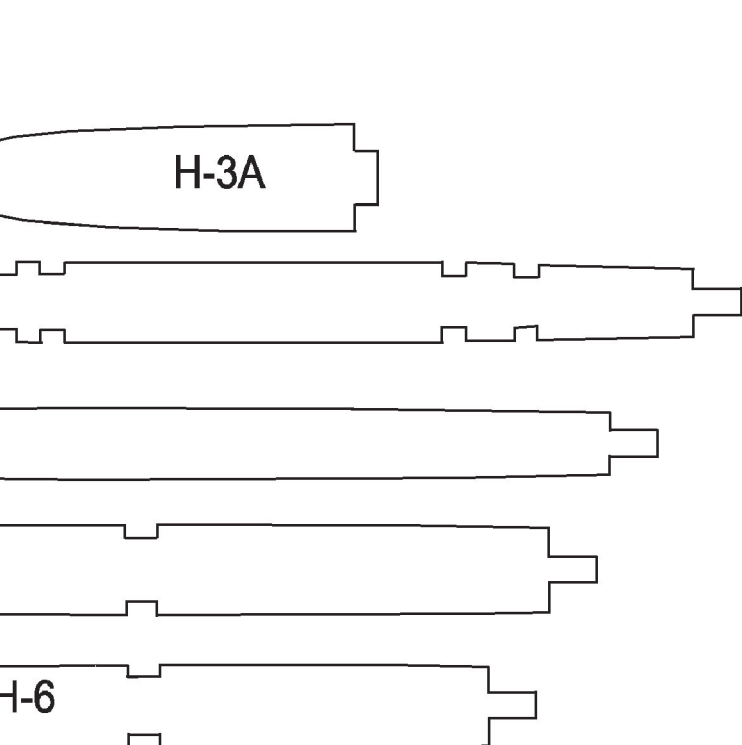

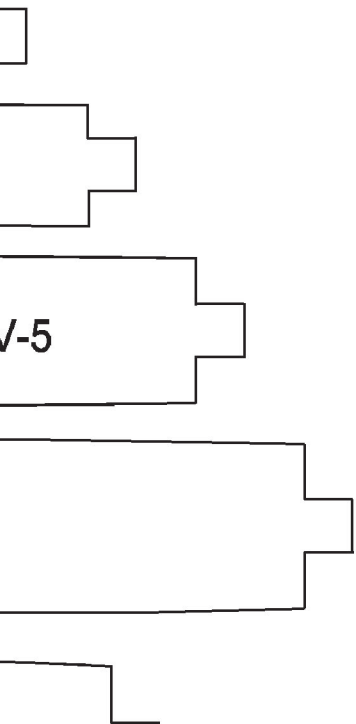

V-5

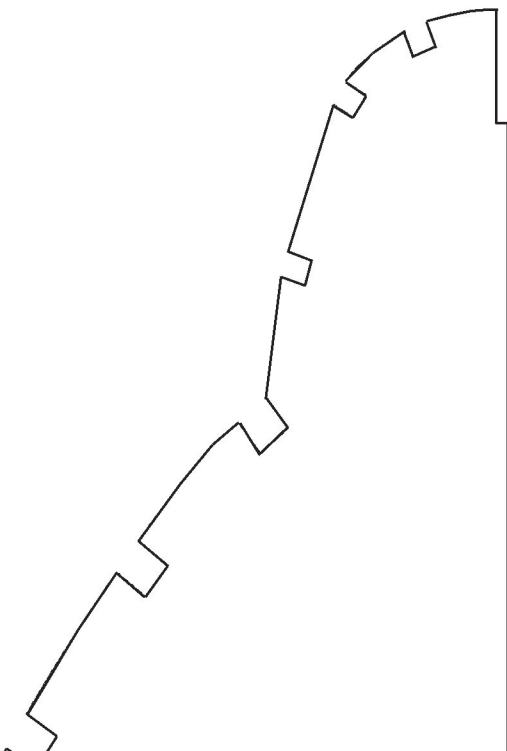

1/8 BALSAM

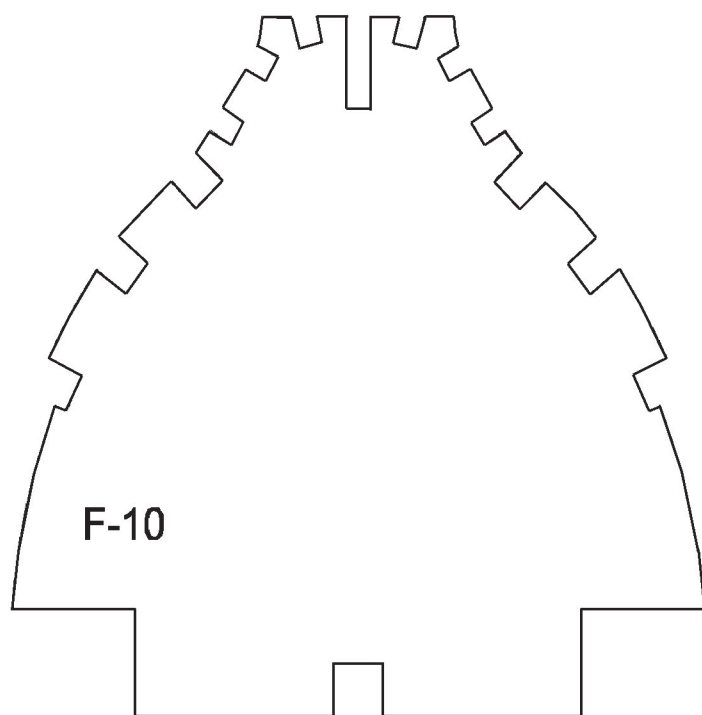

A

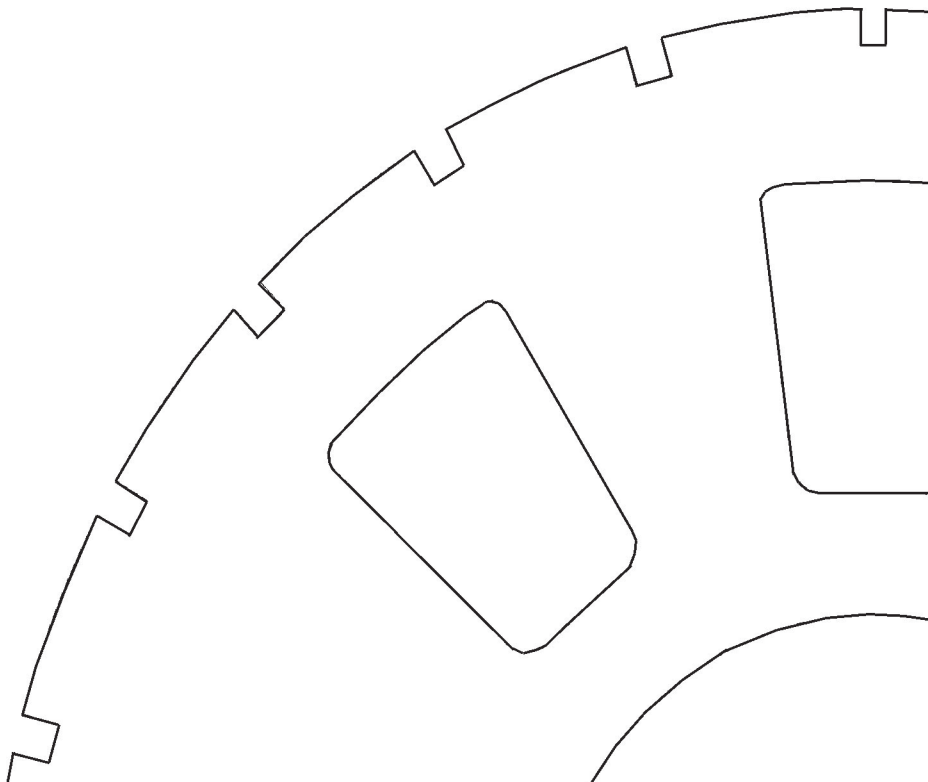

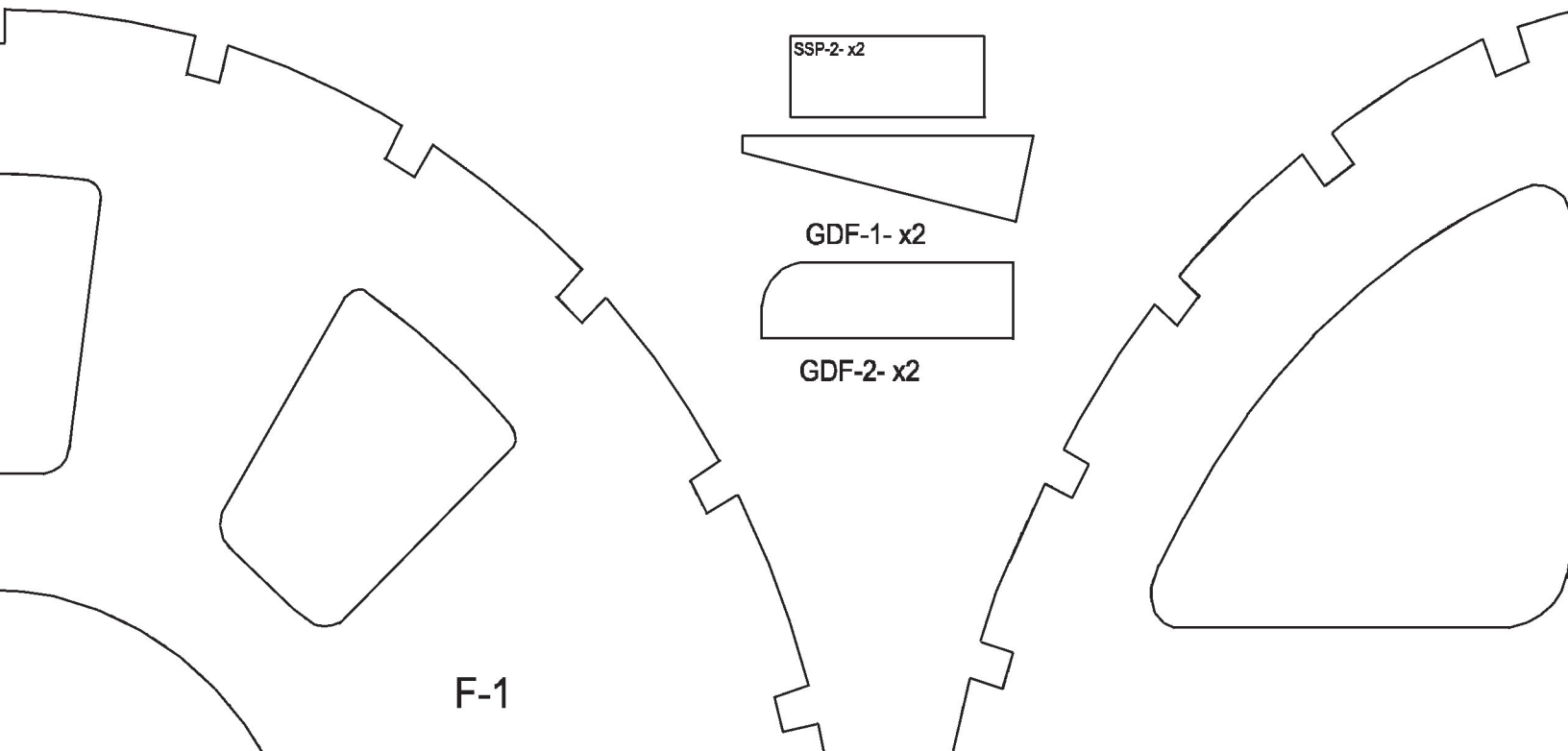

1/8

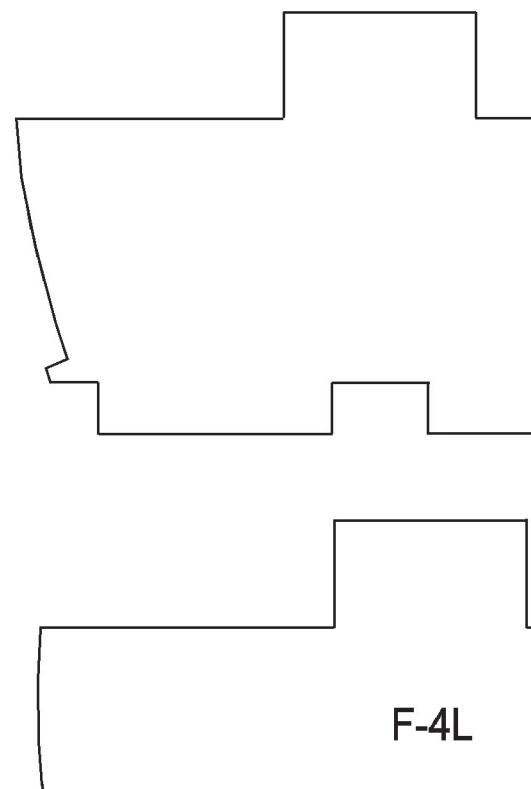
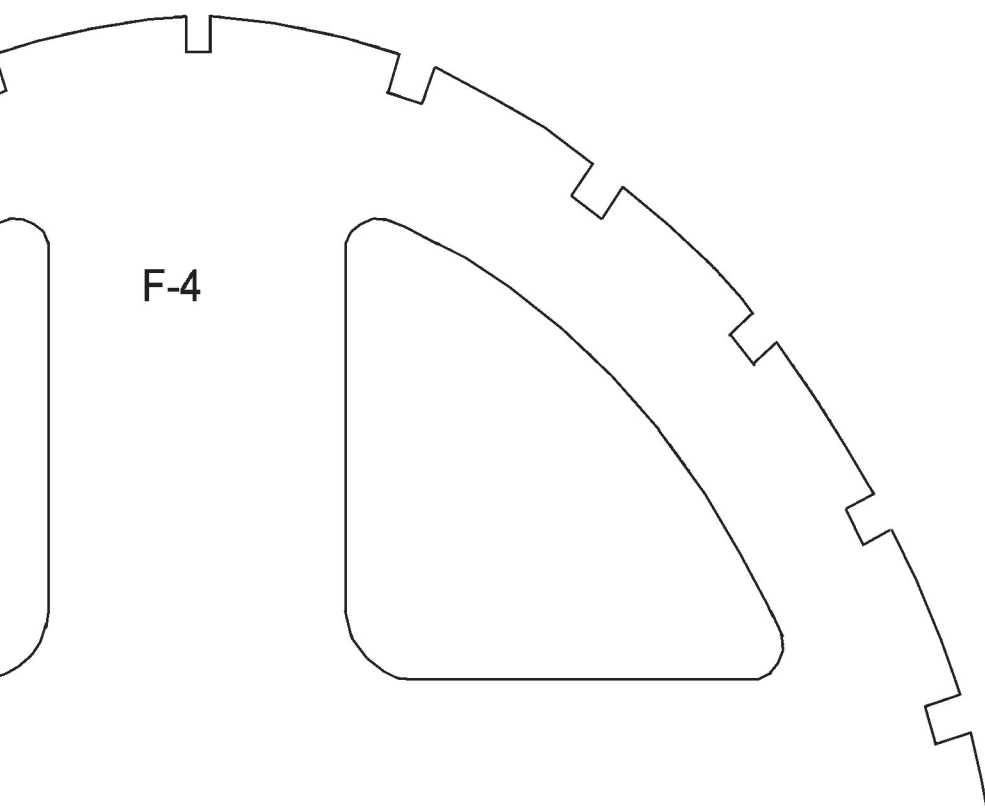

B LITE PLY

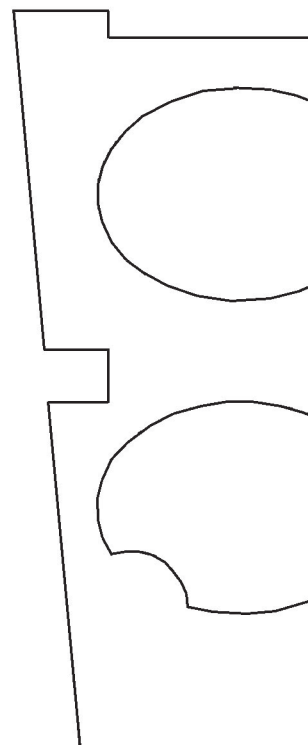
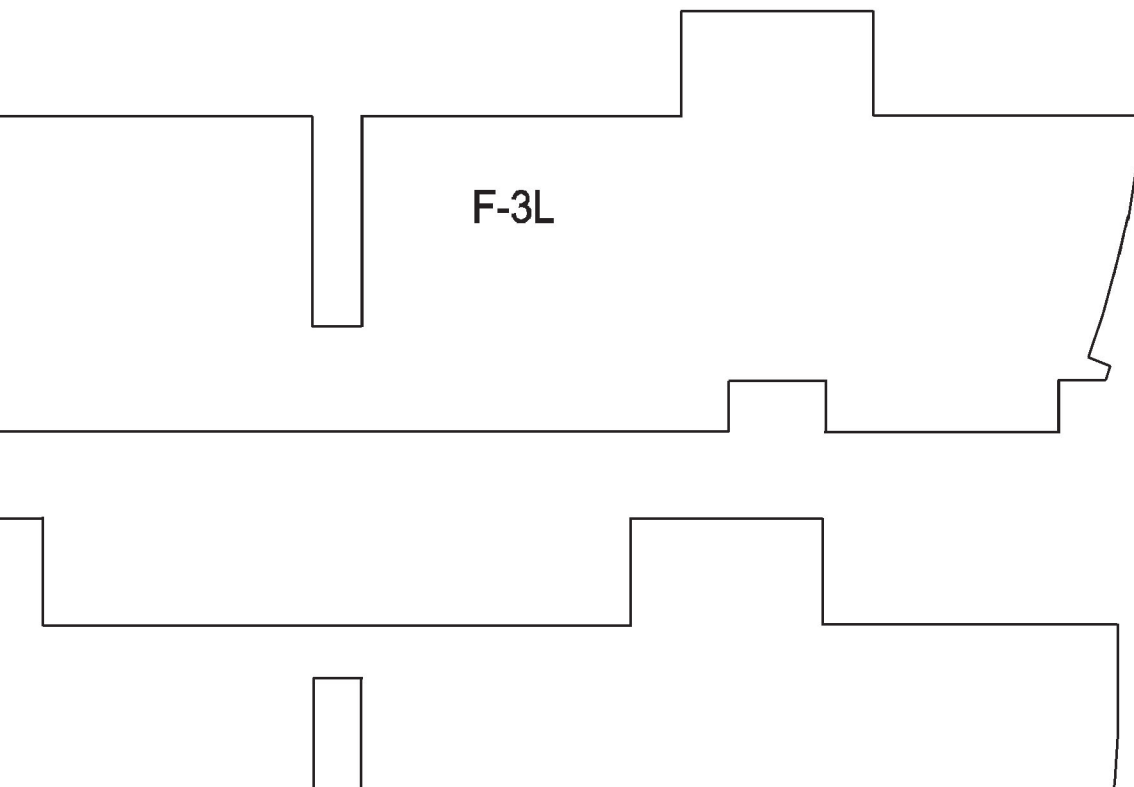

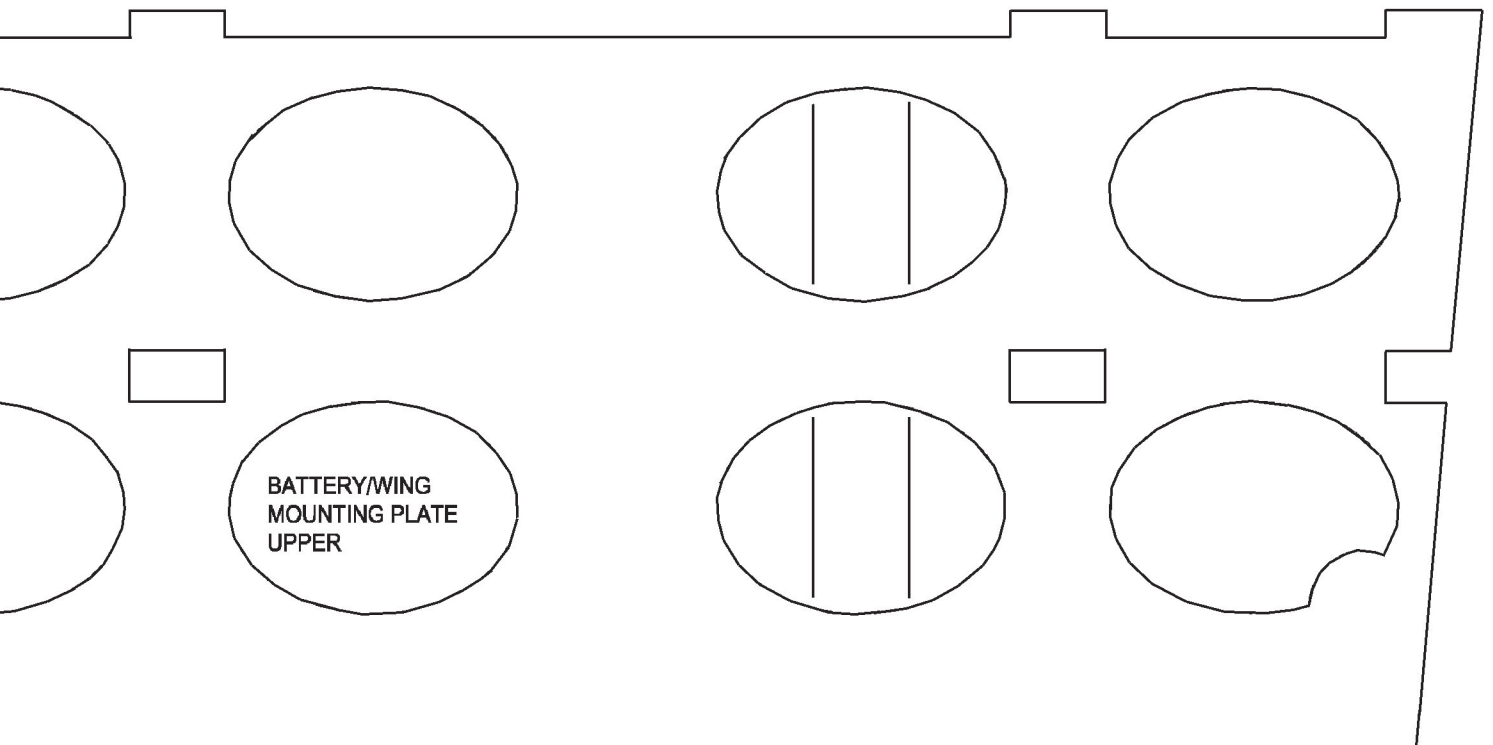

BATTERY/WING
MOUNTING PLATE
UPPER

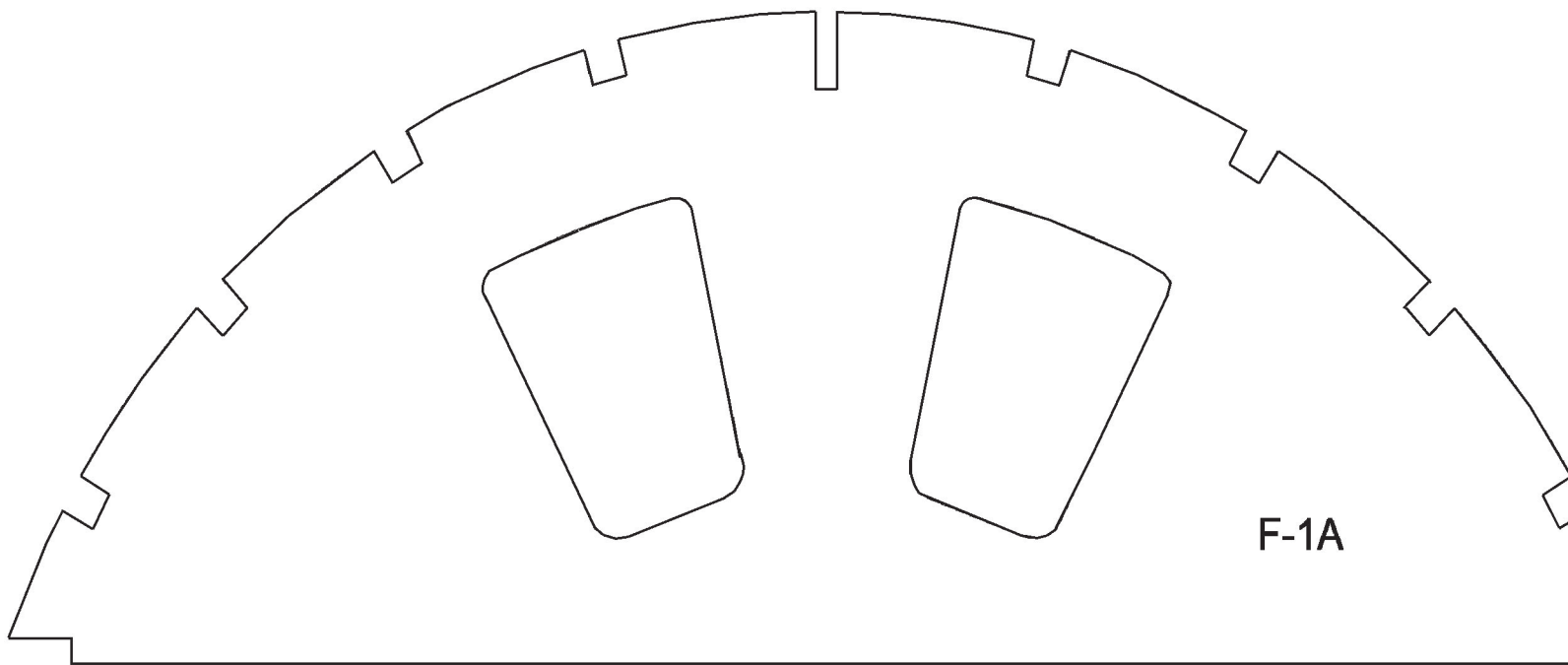

F-1A

1/4 B/

CO
3 E
CIP

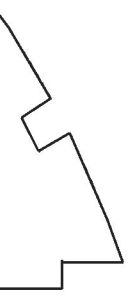
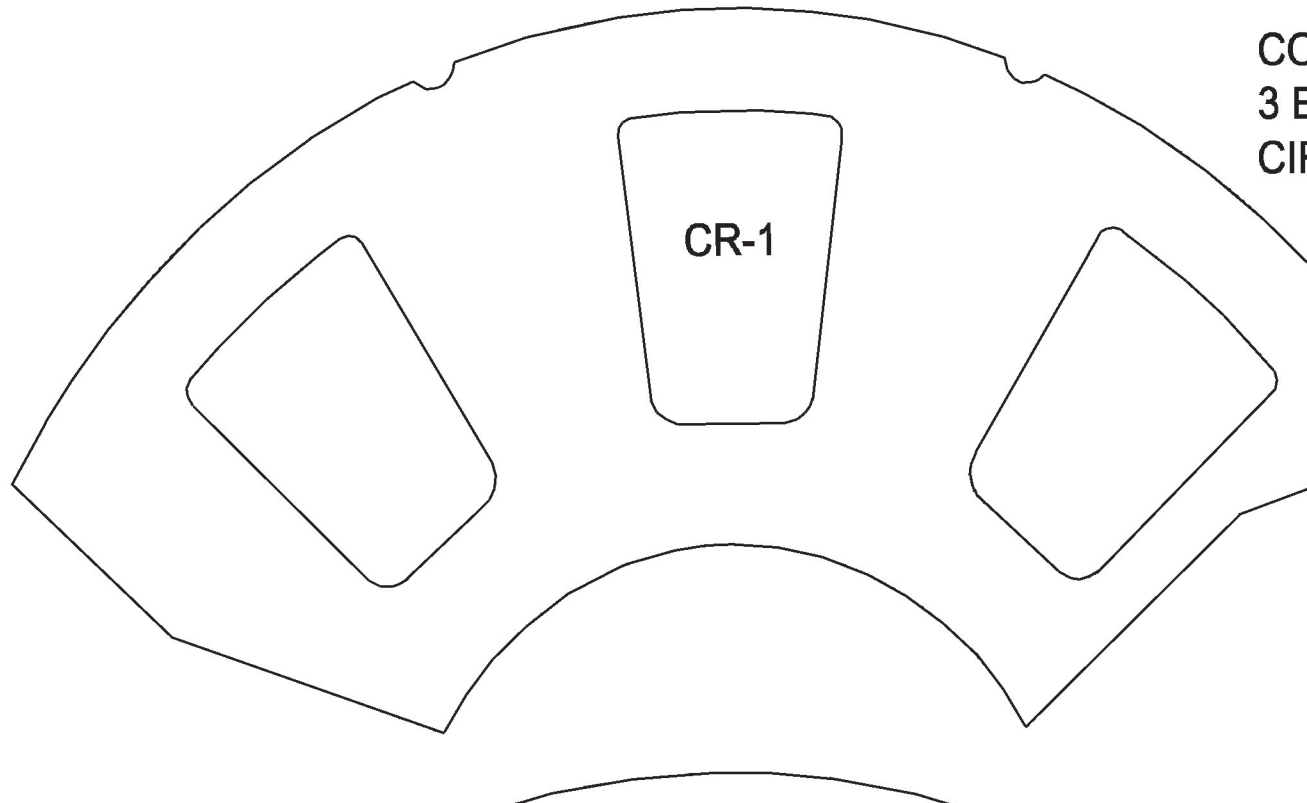

ALSA

COWL RINGS FROM 1/4 BALSA
3 EACH NEEDED- ONLY ONE HAS
CIRCLE CUT OUTS (FOR GUNS)

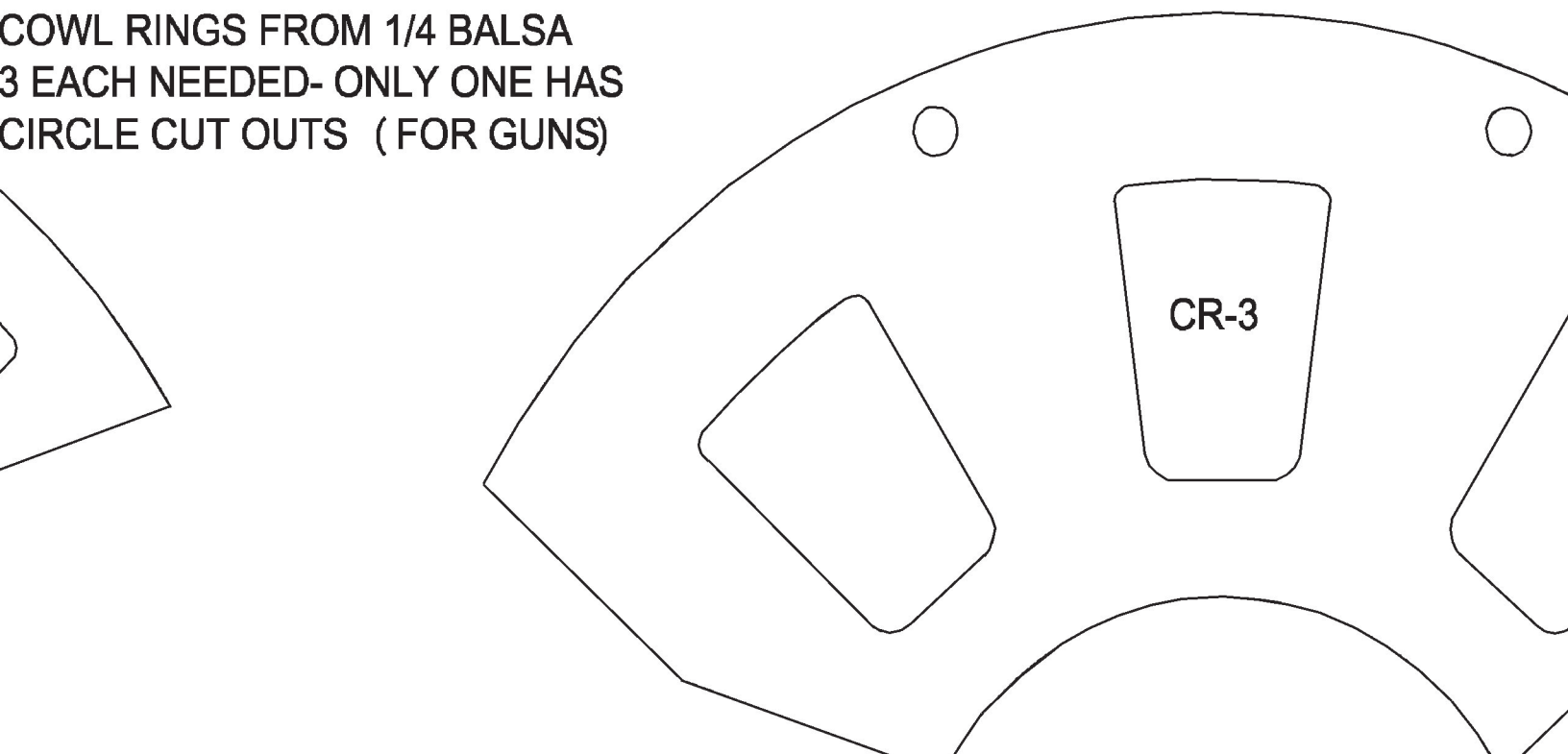

1/8

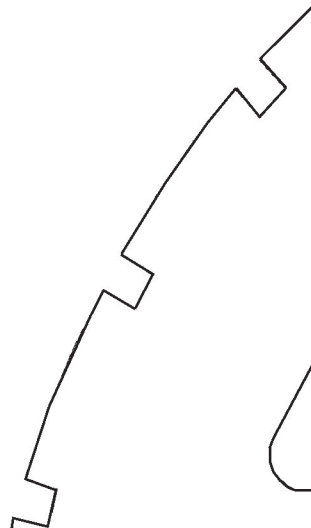
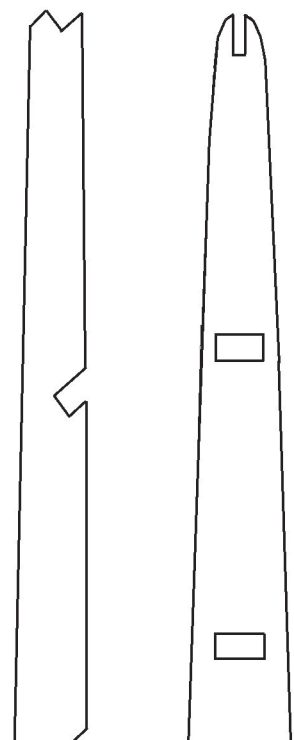
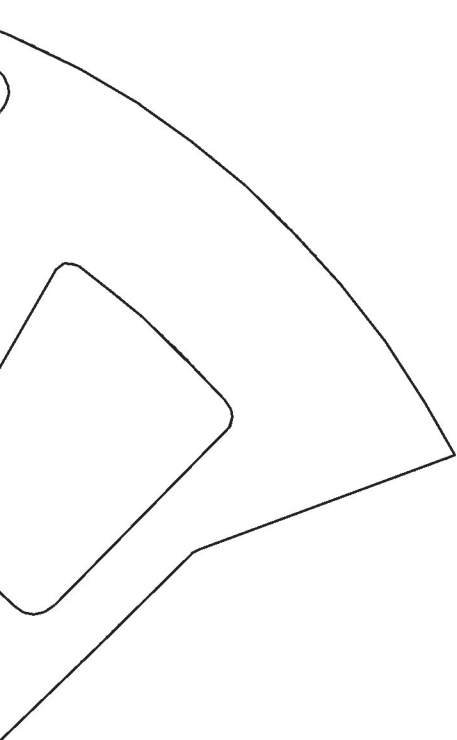

8 REG. PLY

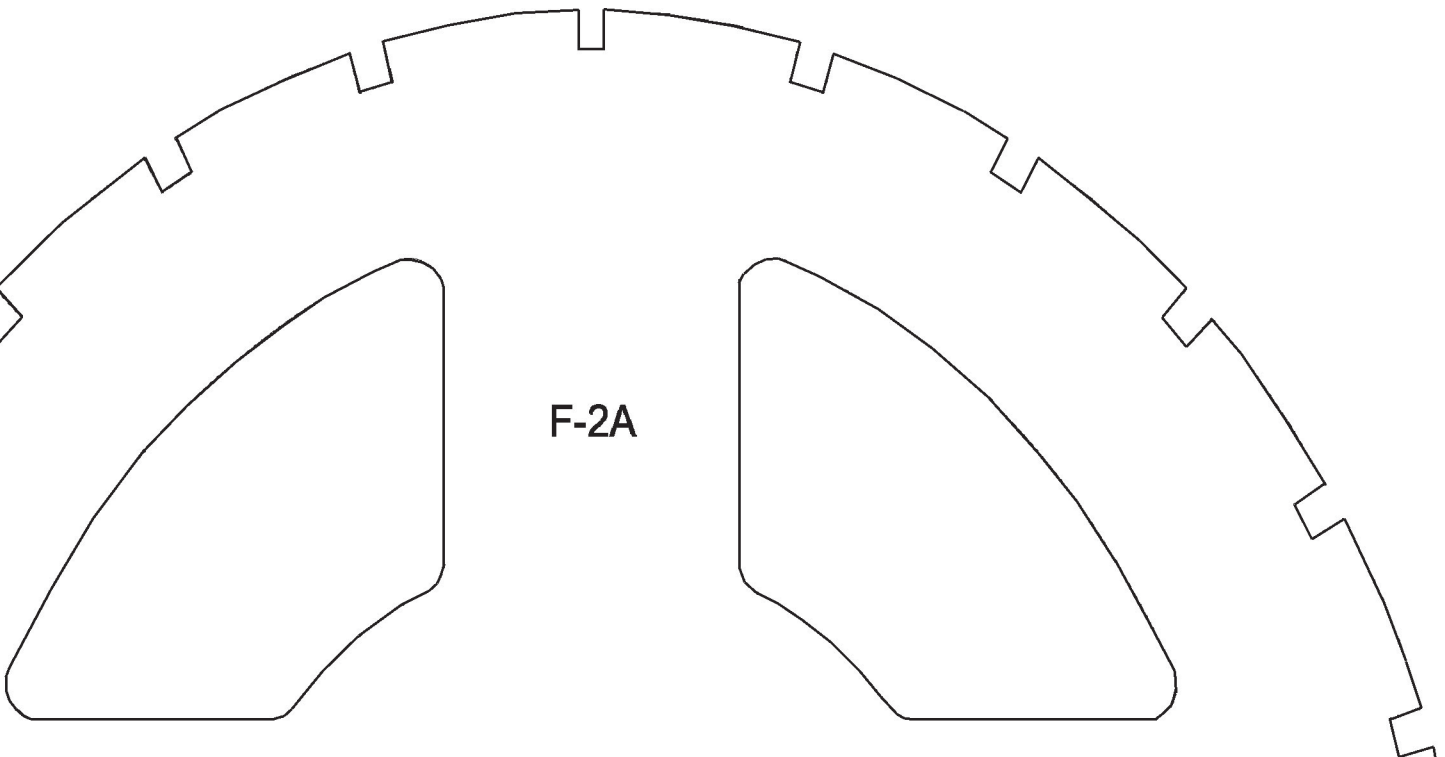

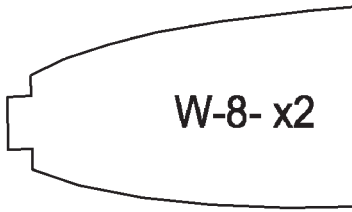

W-8- x2

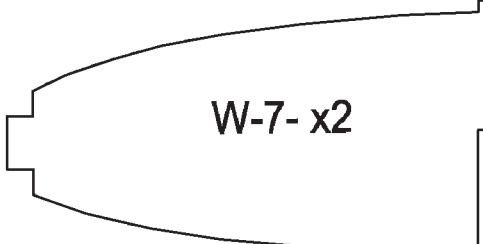

W-7- x2

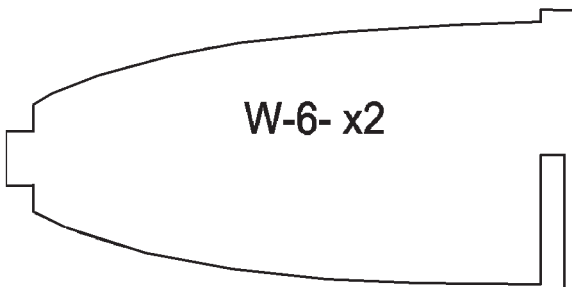

W-6- x2

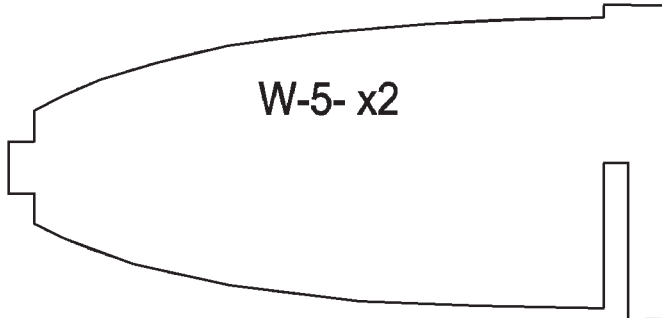

W-5- x2

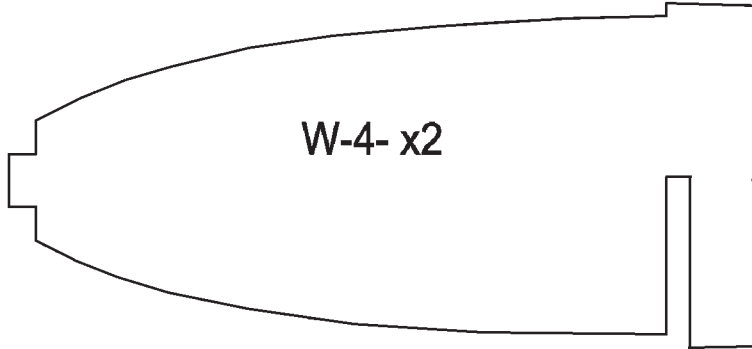

W-4- x2

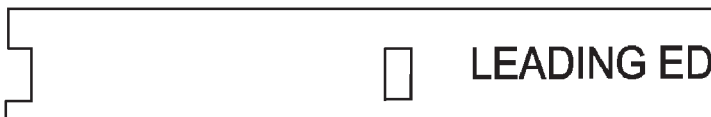

LEADING ED

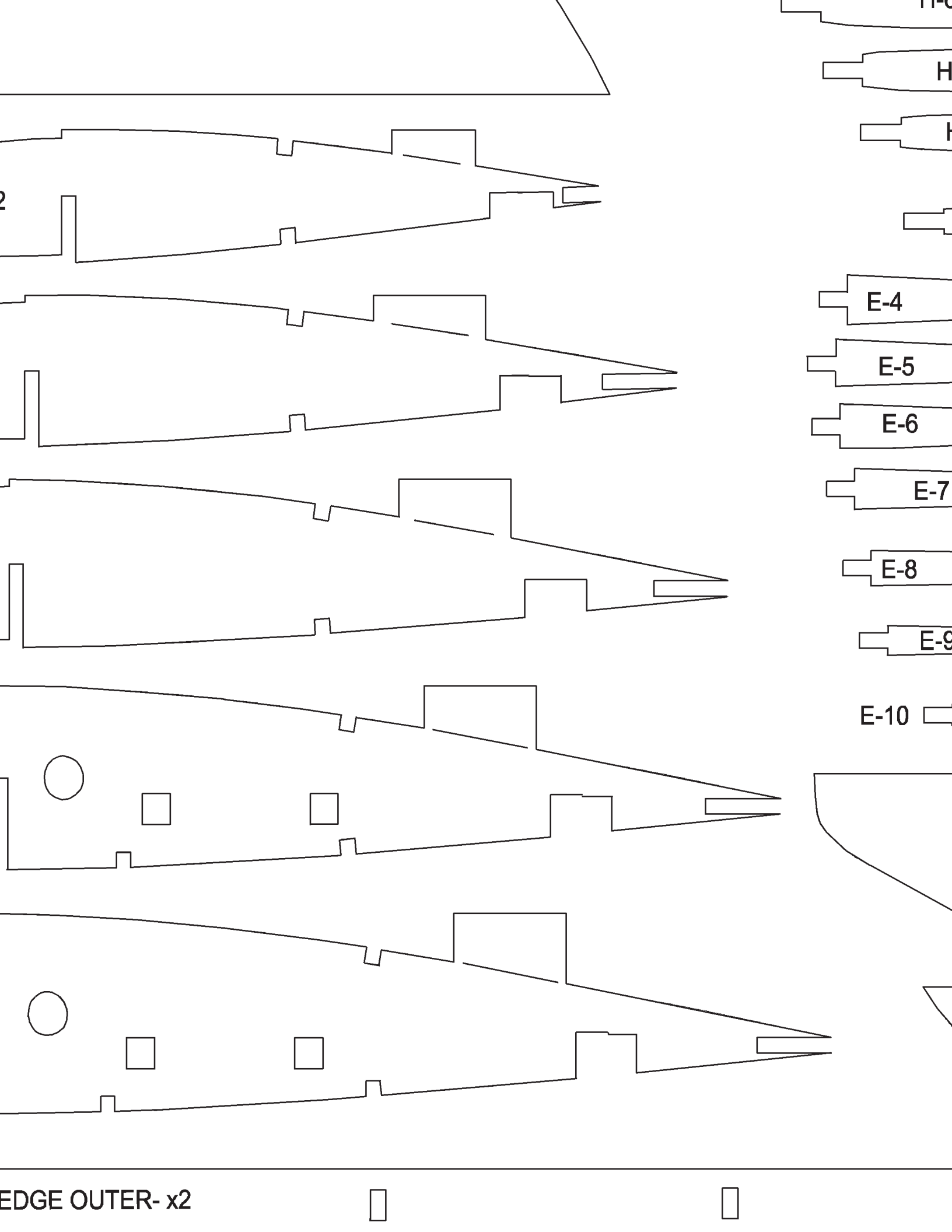

2

H

H

E-4

E-5

E-6

E-7

E-8

E-9

E-10

EDGE OUTER- x2



H-6

H-7

H-8

H-9

E-1

E-2

E-3

E-4

E-5

E-6

E-7

E-8

E-9

E-10

E-11

E-12

E-13

E-14

E-15

E-16

V-7

V-8

R-3

R-4

R-5

R-6

R-7

R-8

R-9- x2



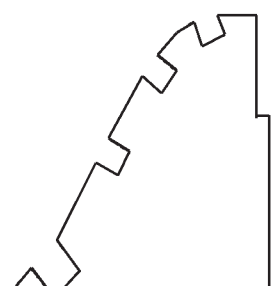
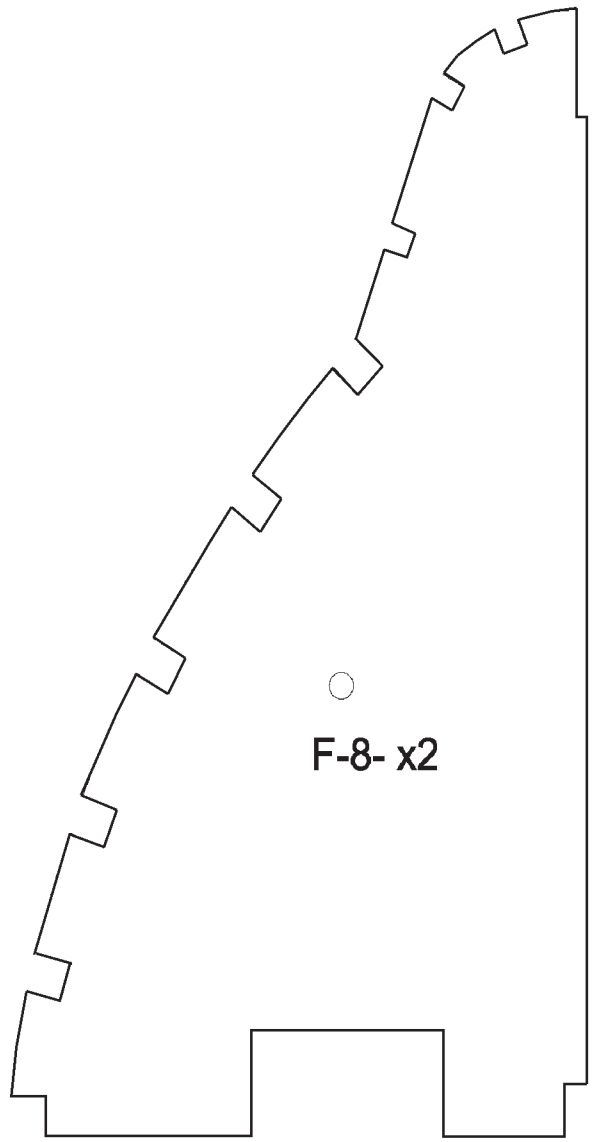
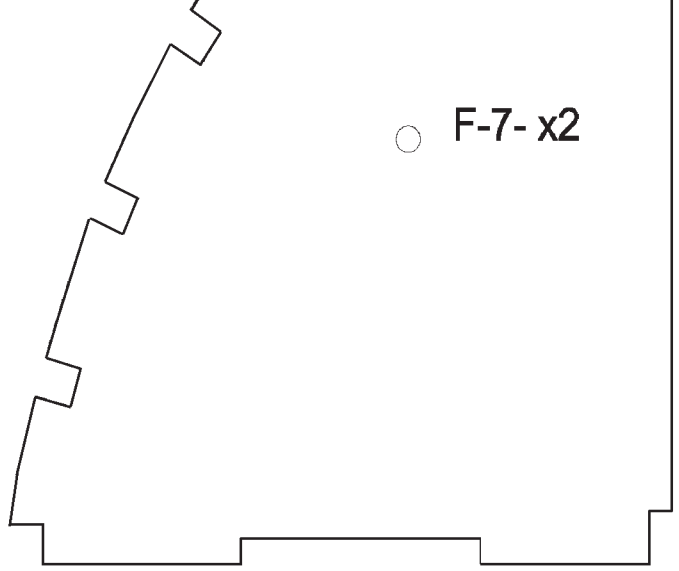
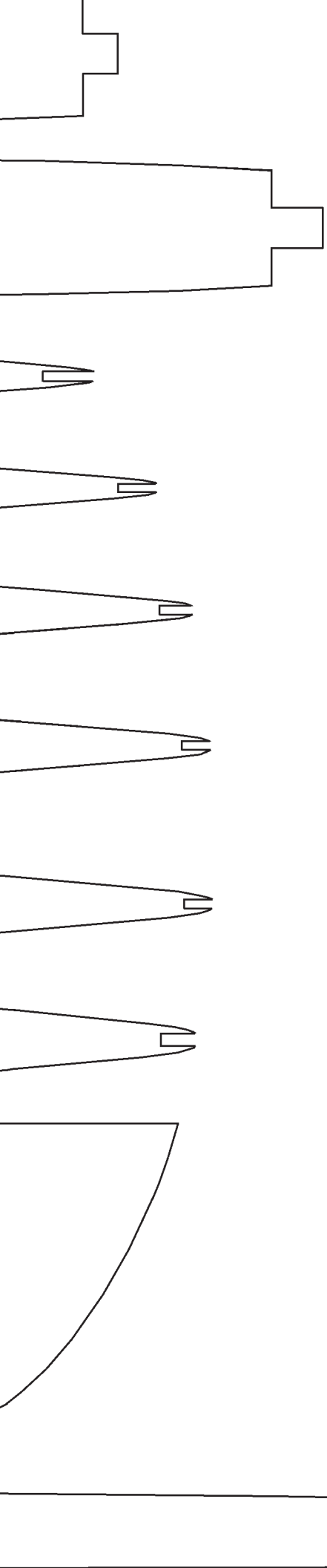

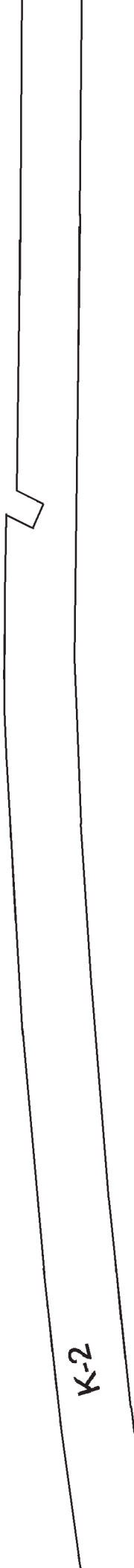
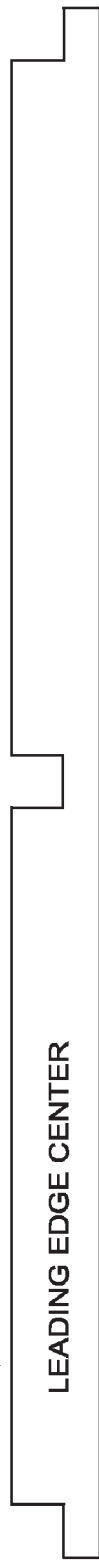
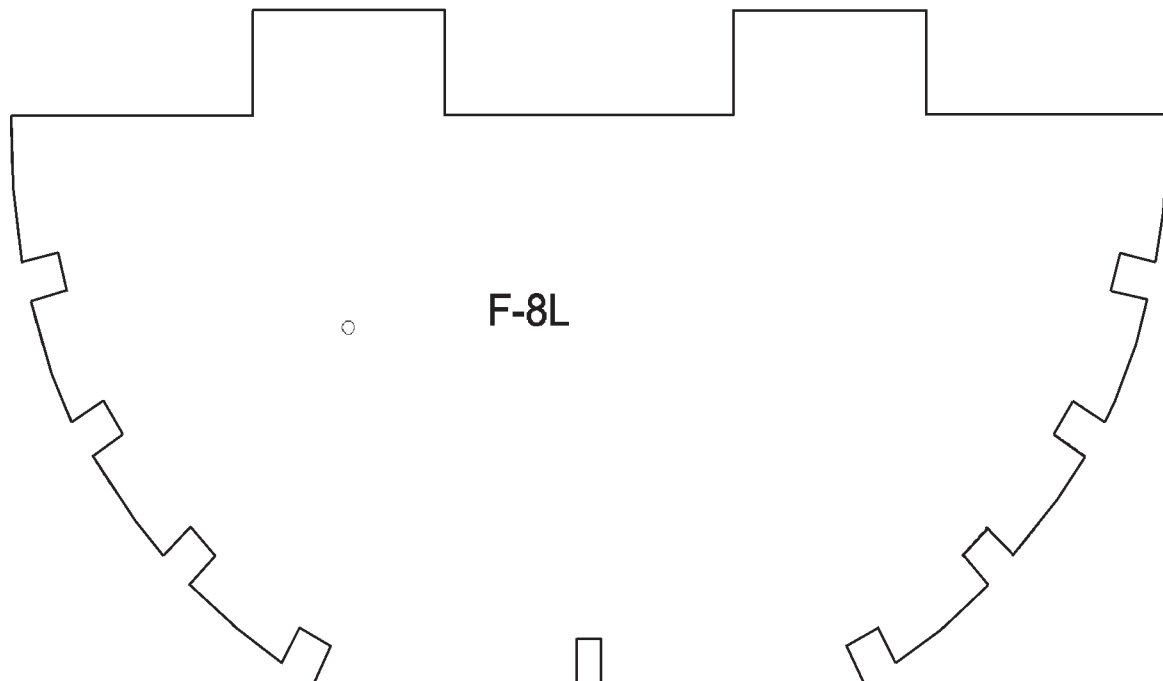
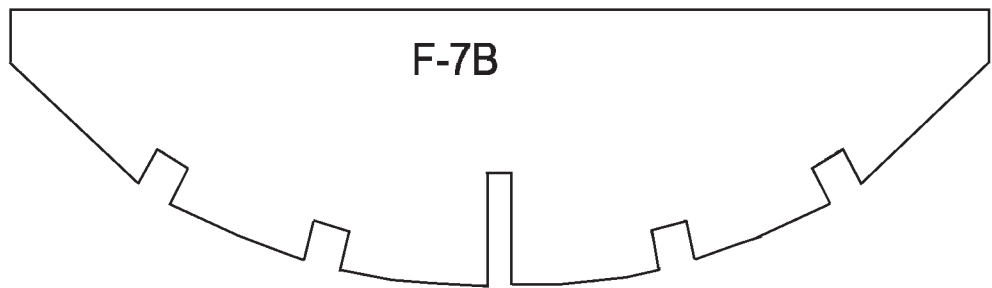
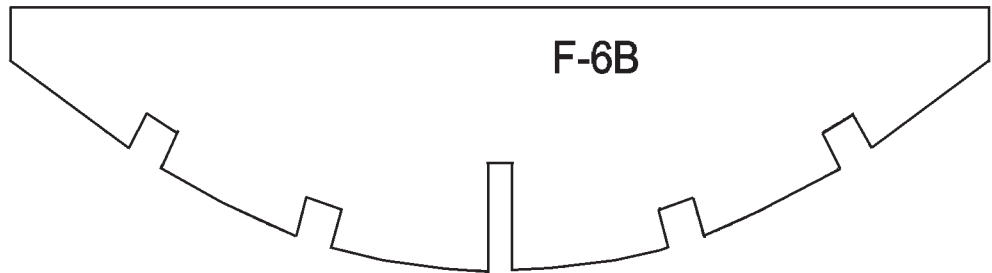
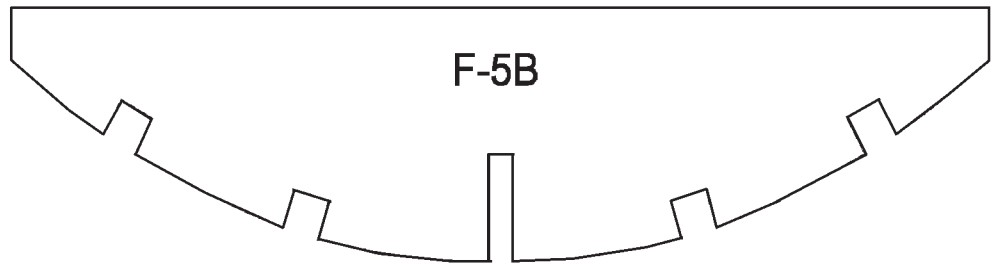
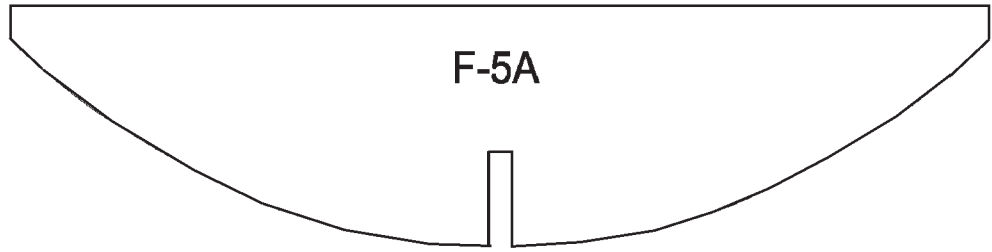

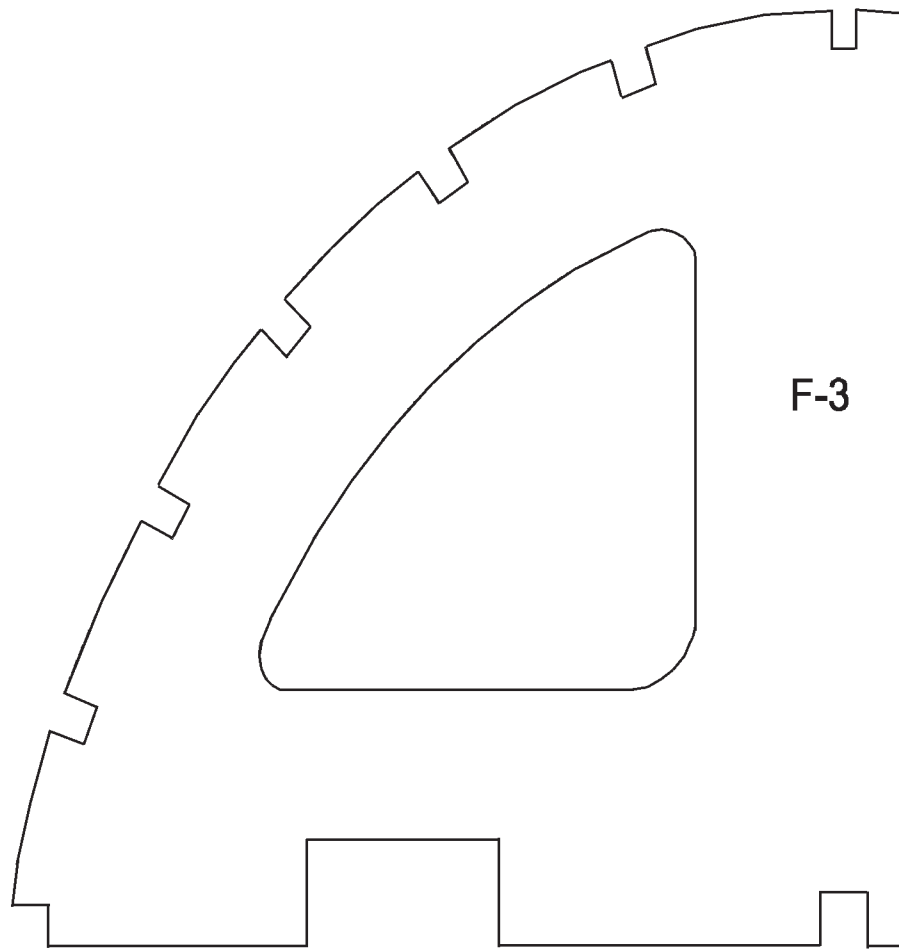
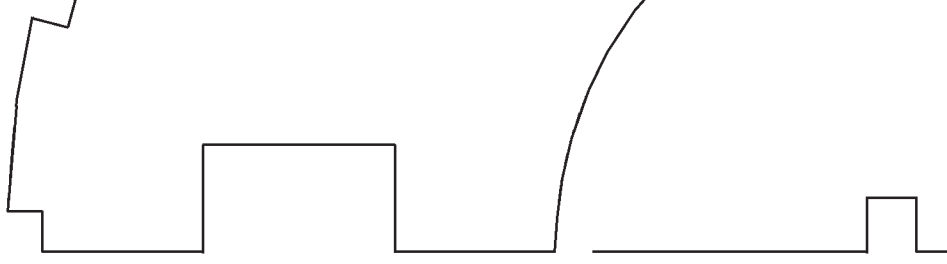

F-3

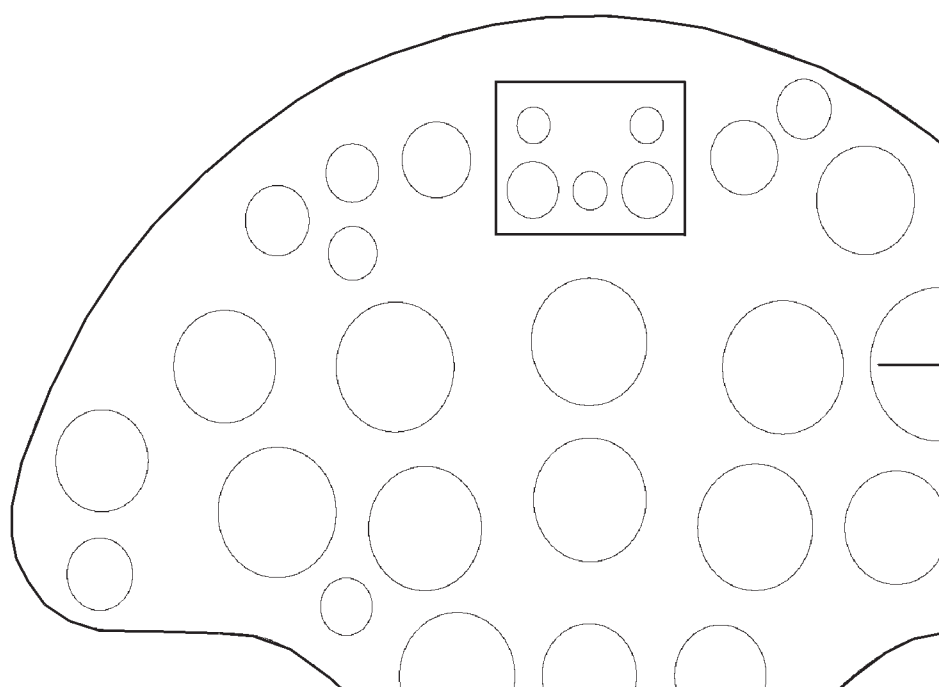

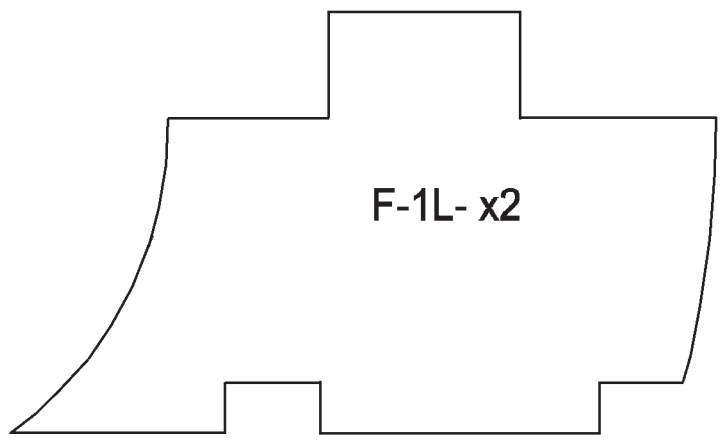
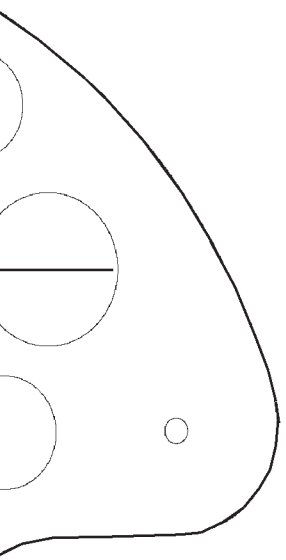
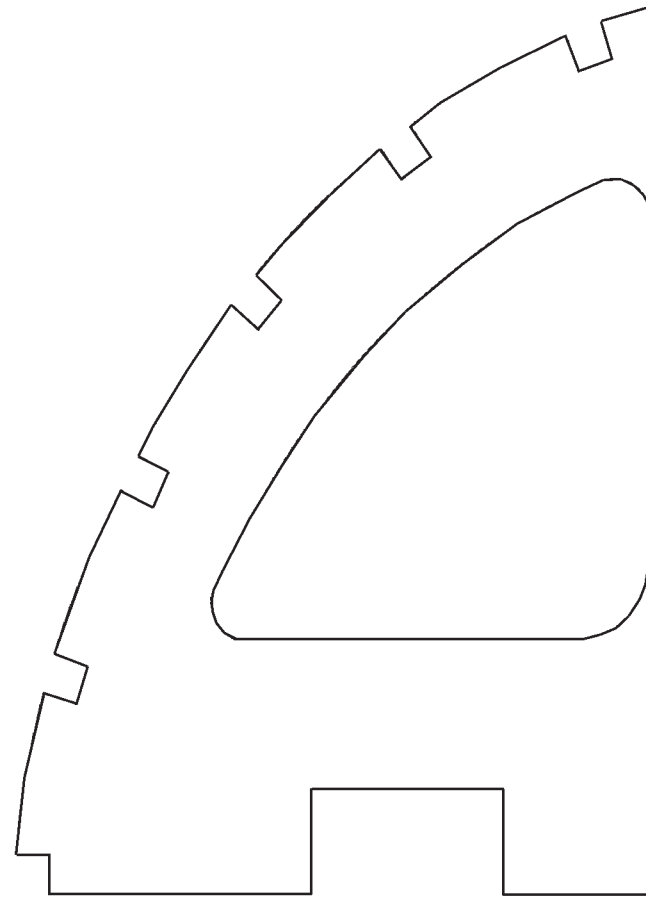
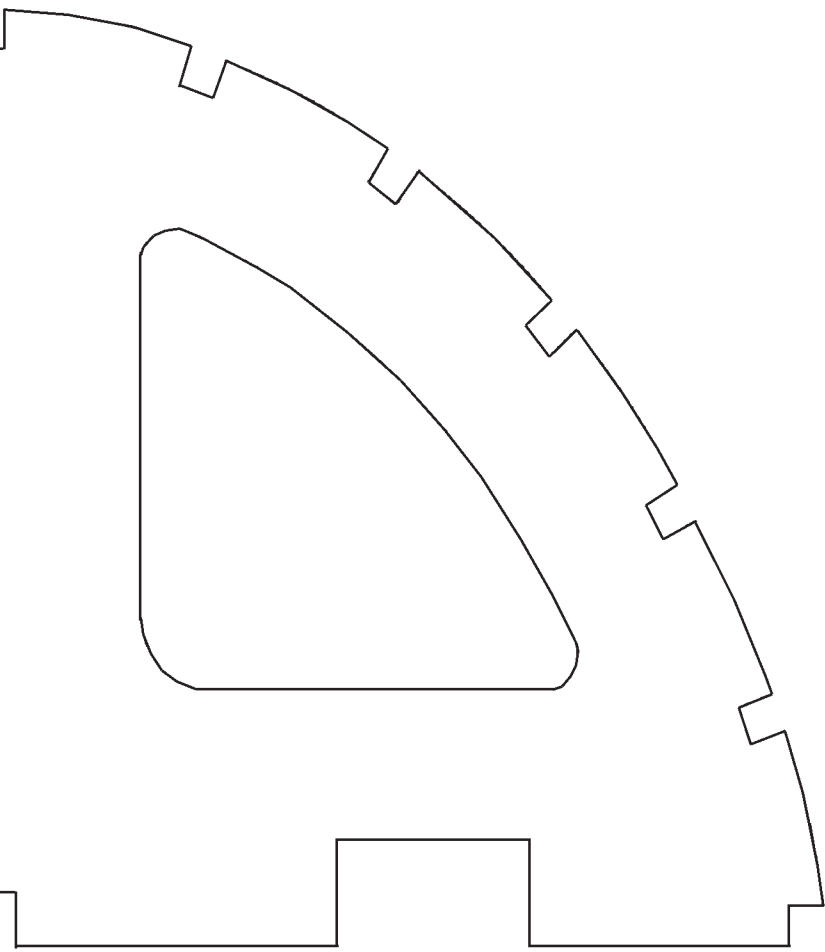
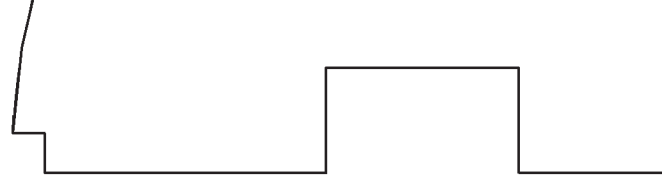
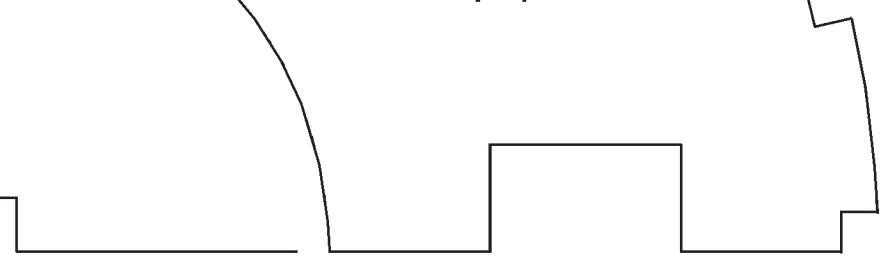

F-1L- x2

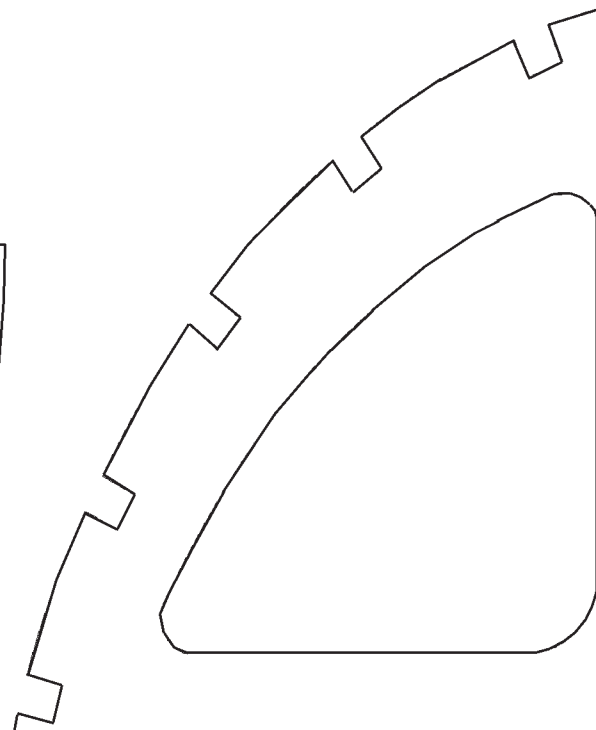

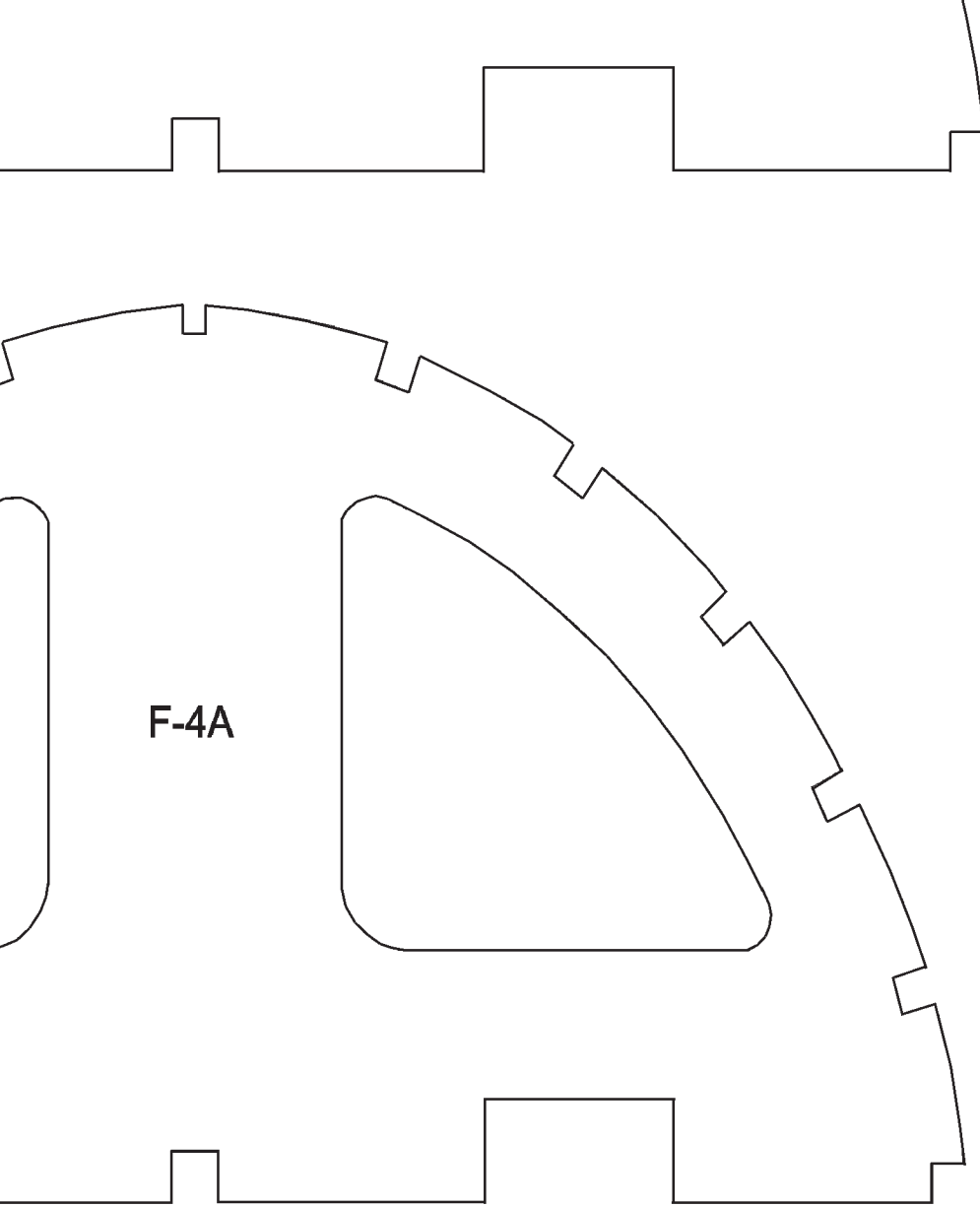

F-4A

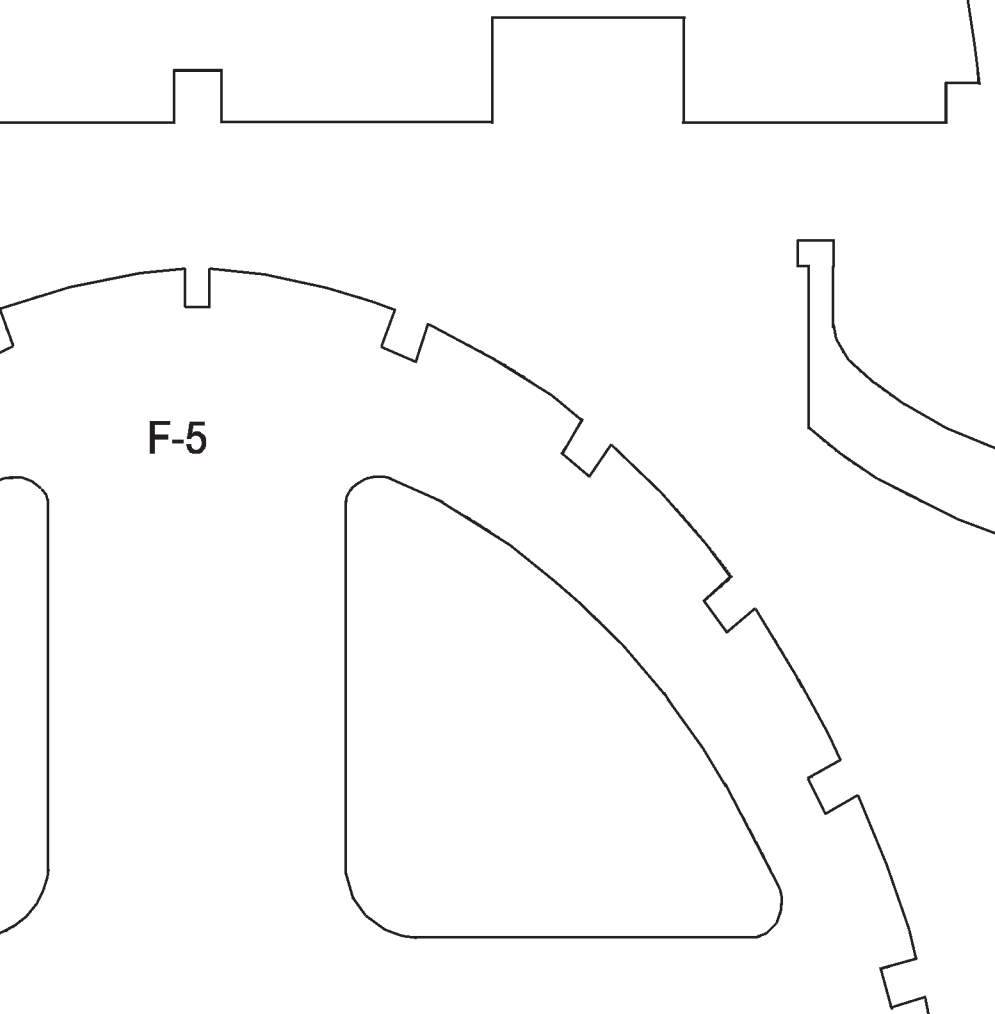

F-5

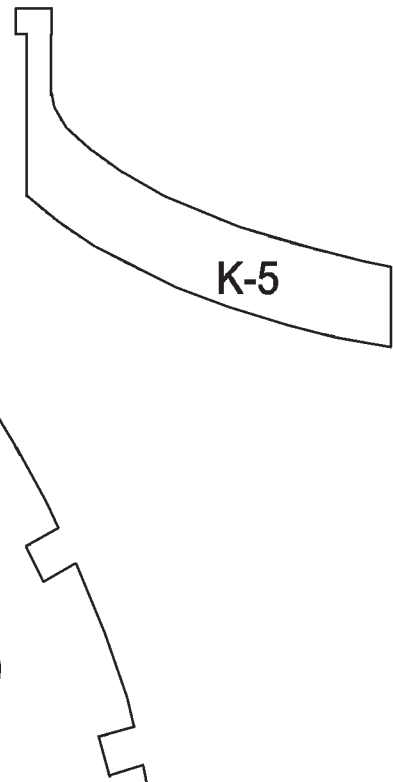

K-5

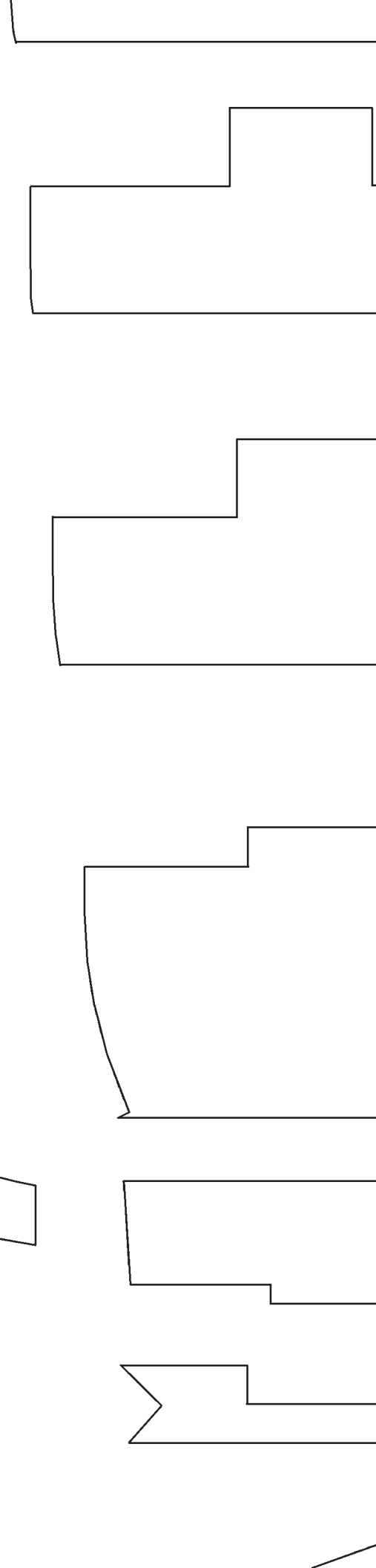



F-4AL

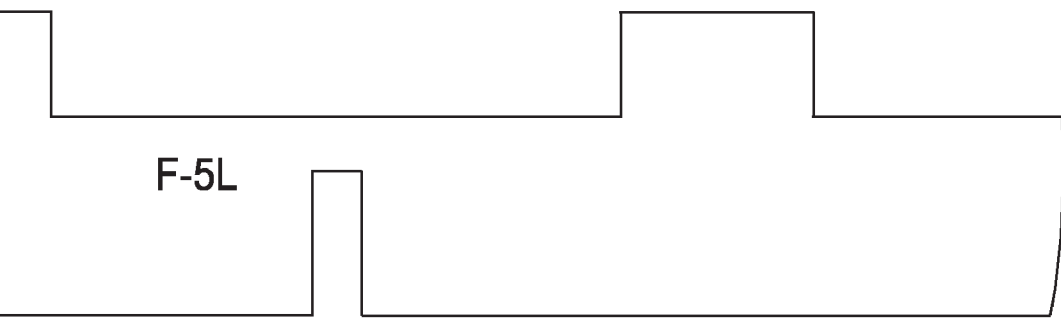

F-5L

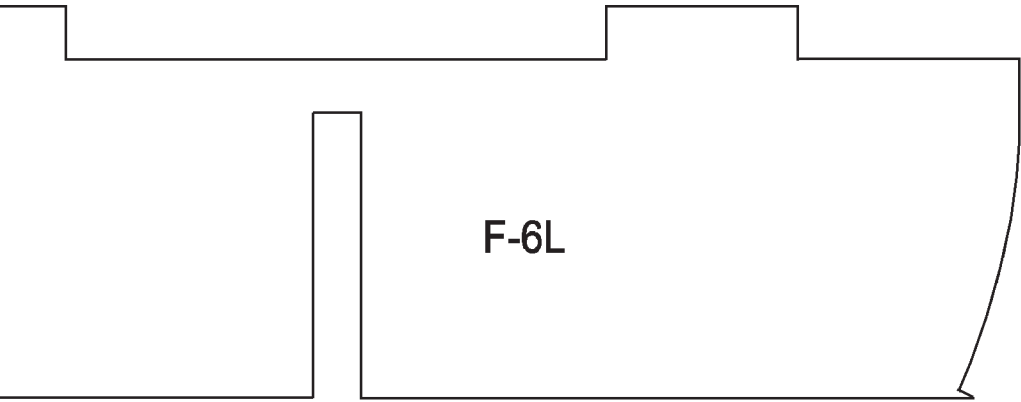

F-6L



WMP-3- x4



F-6U

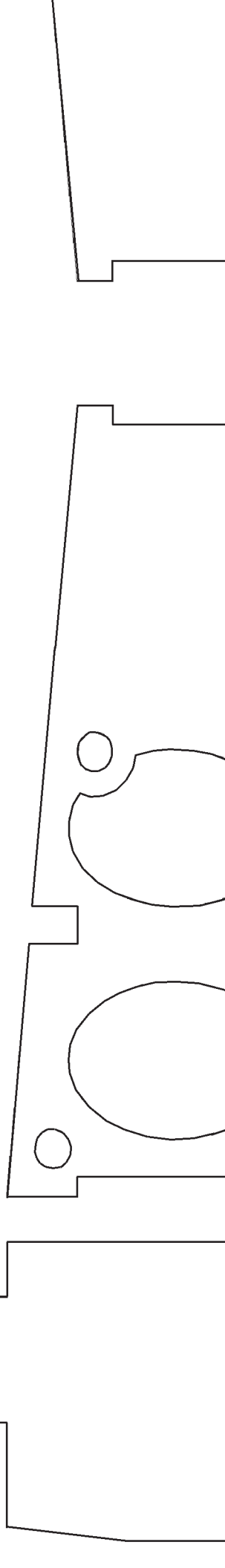

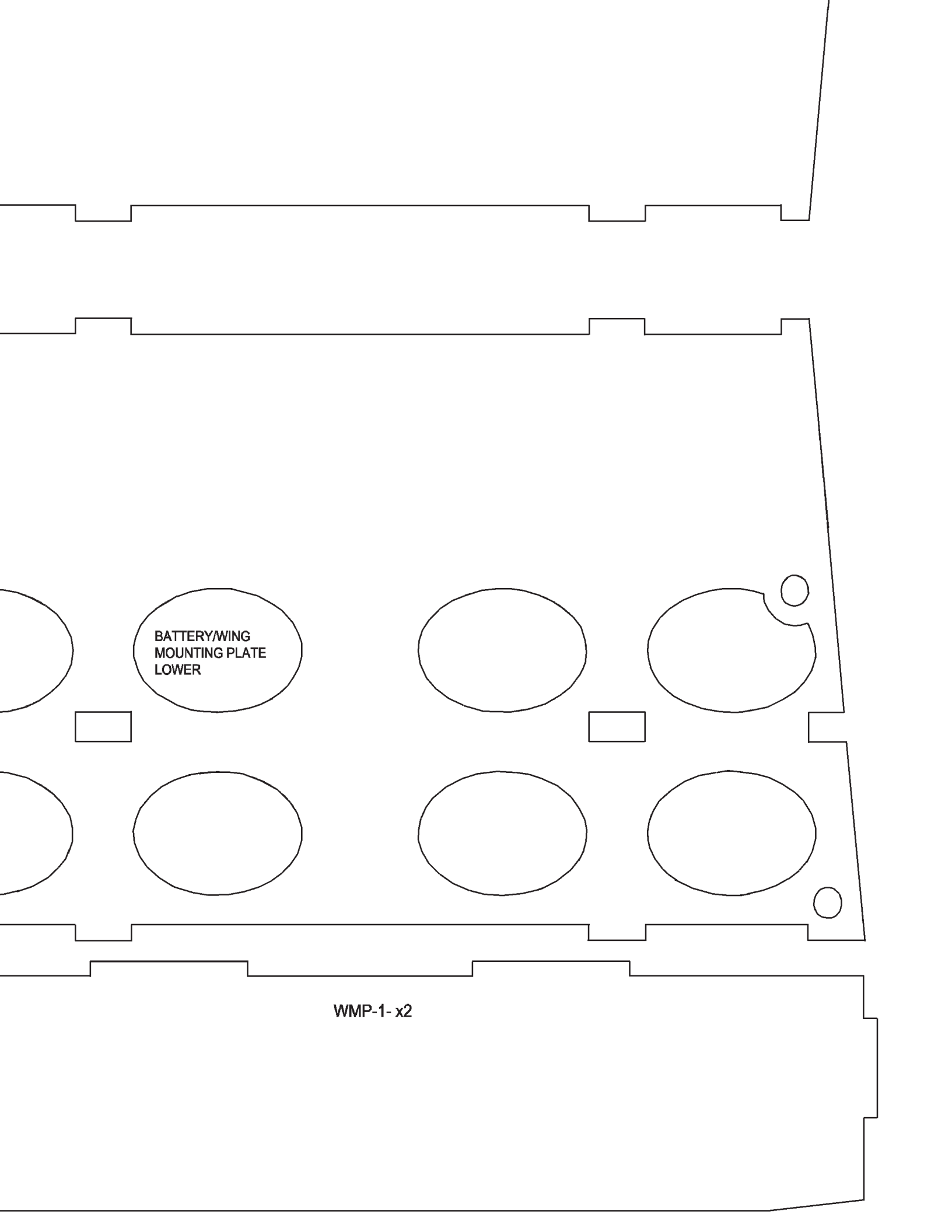

BATTERY/WING
MOUNTING PLATE
LOWER

WMP-1- x2

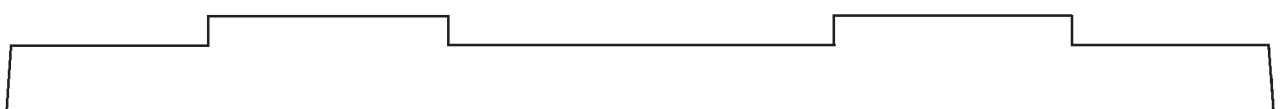
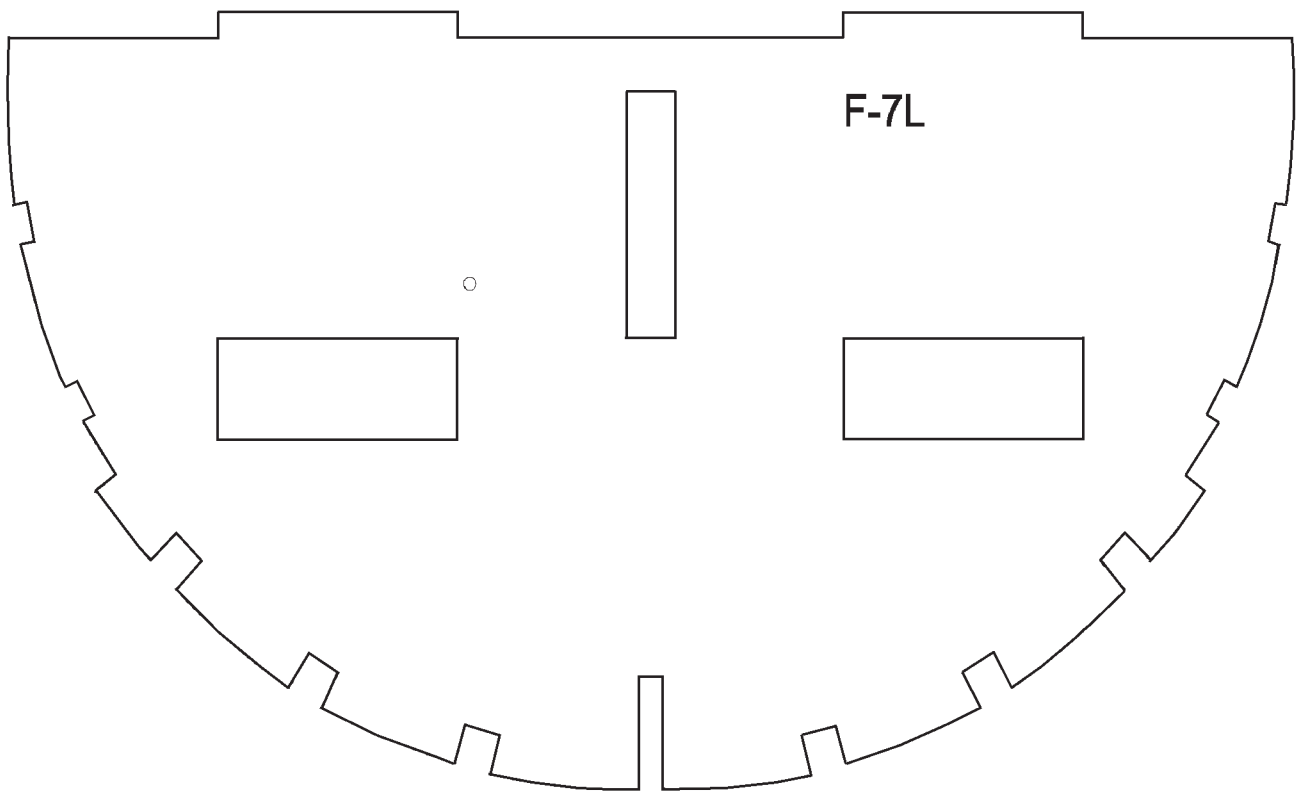
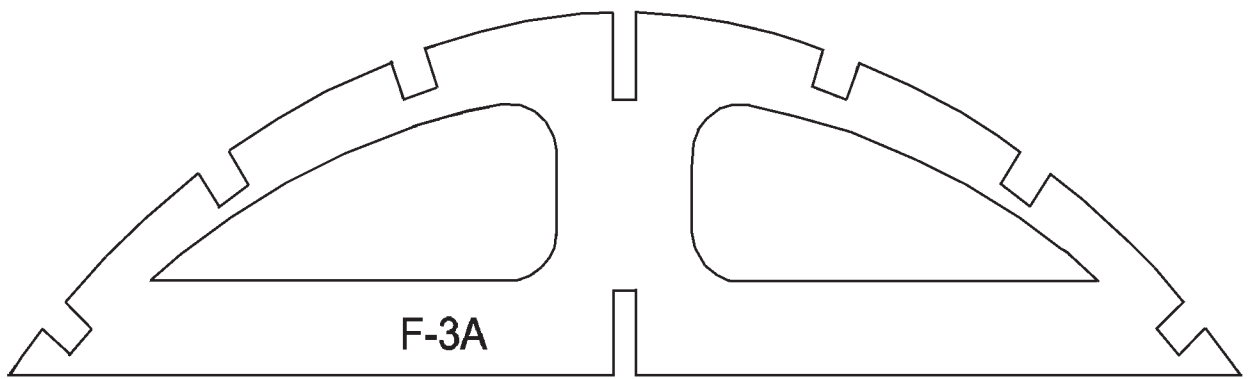
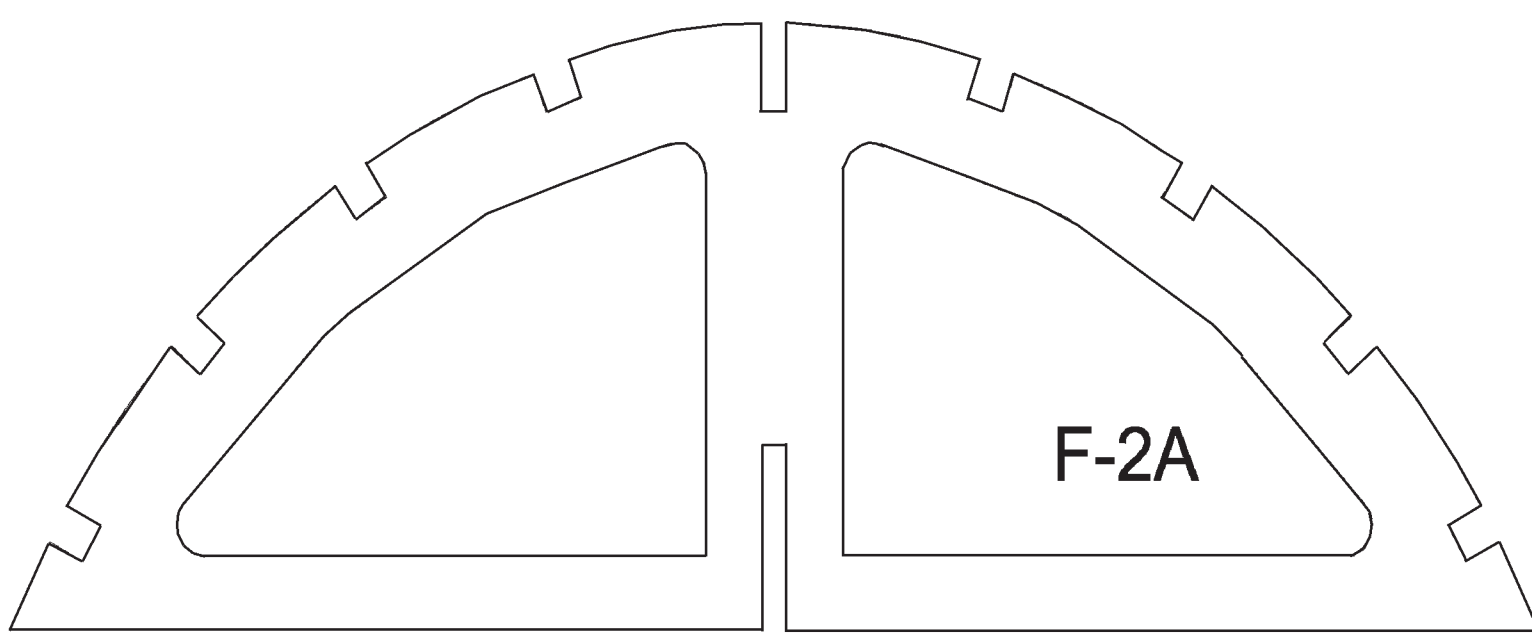

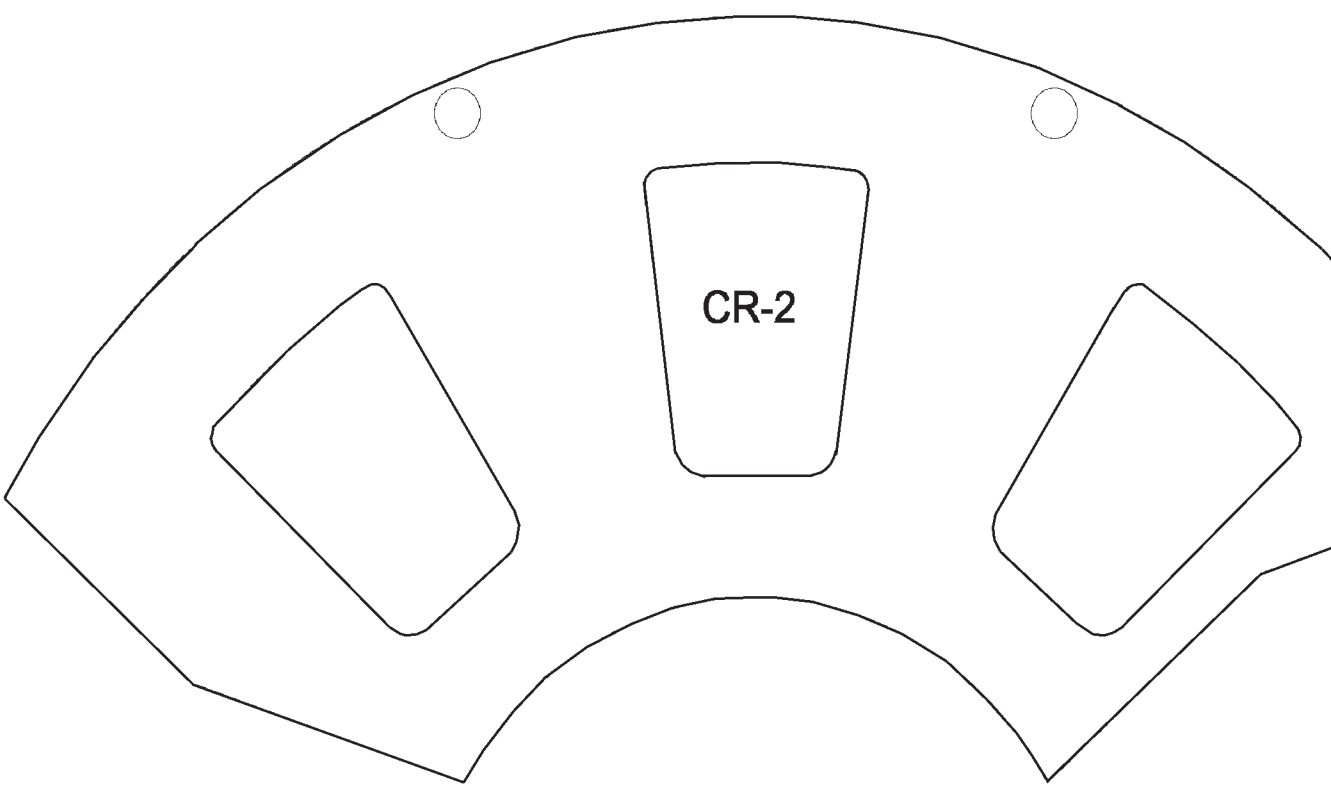

CR-2

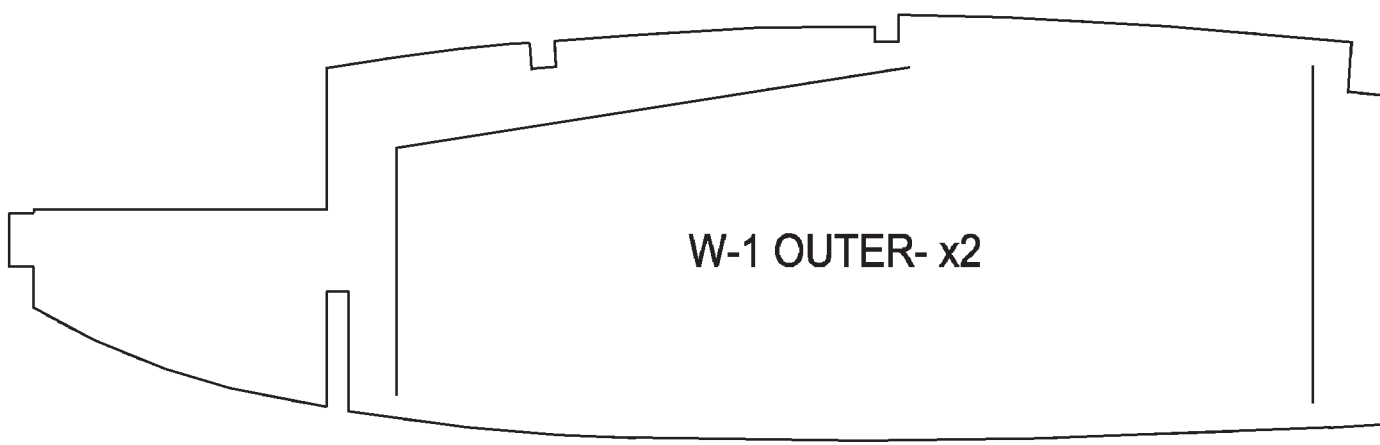

W-1 OUTER- x2

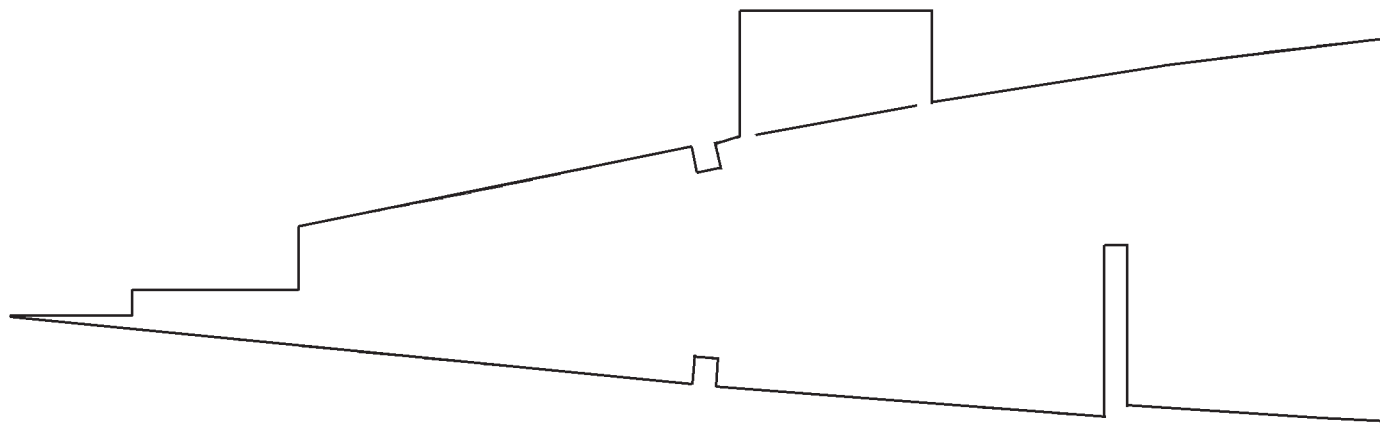

F-11



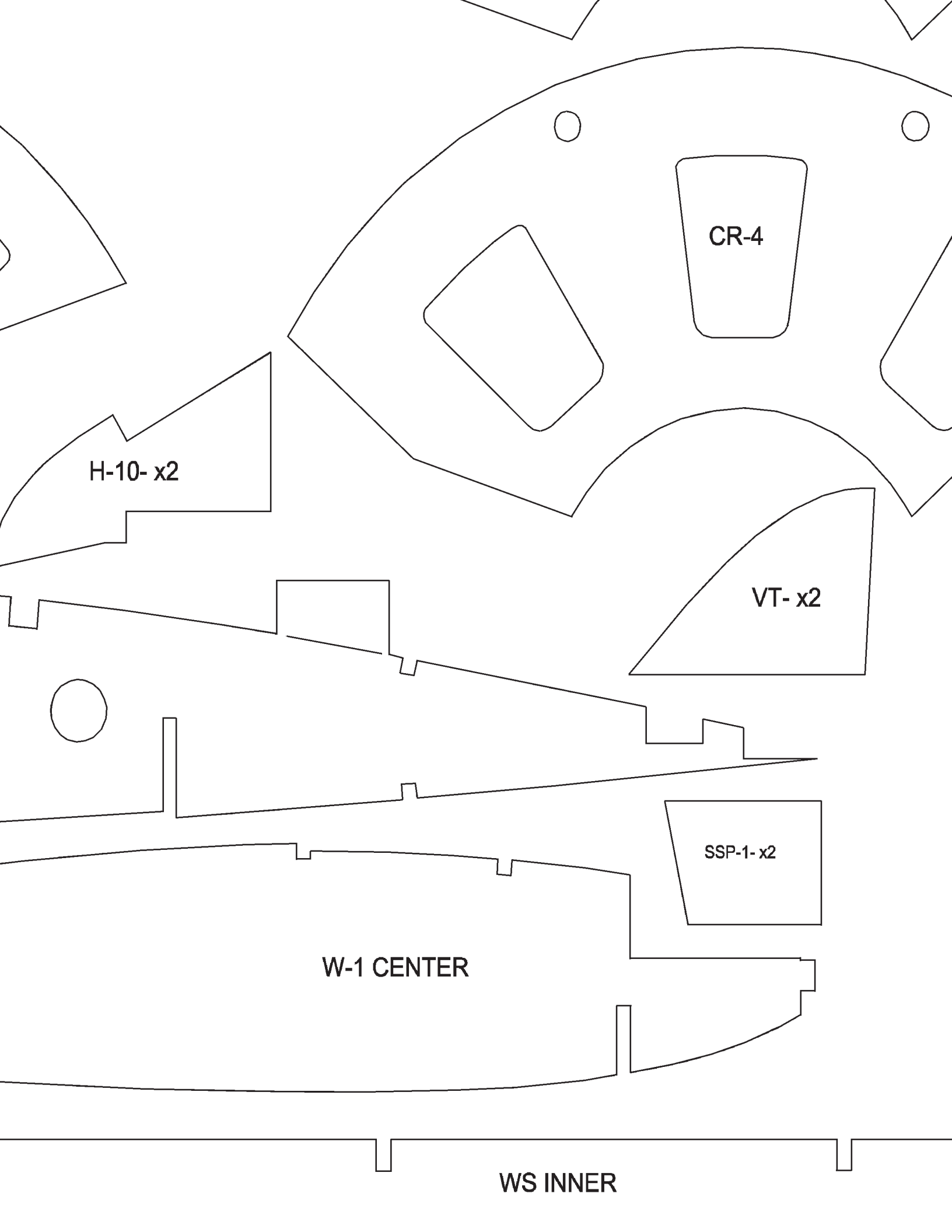

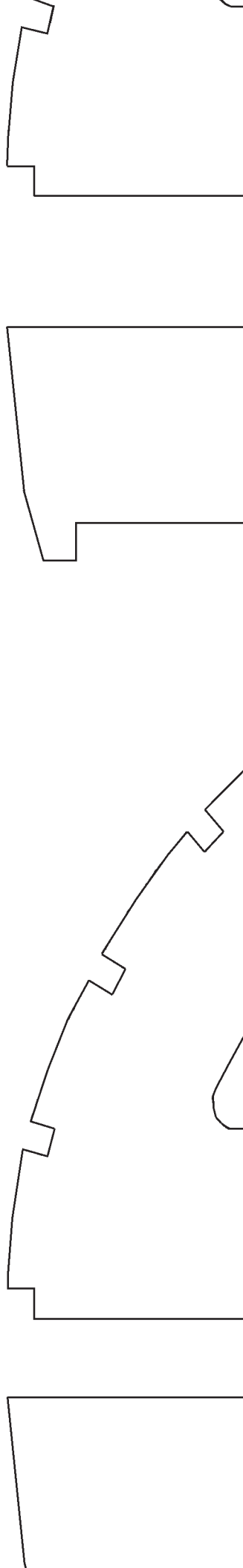
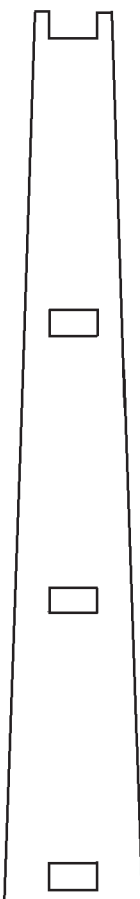
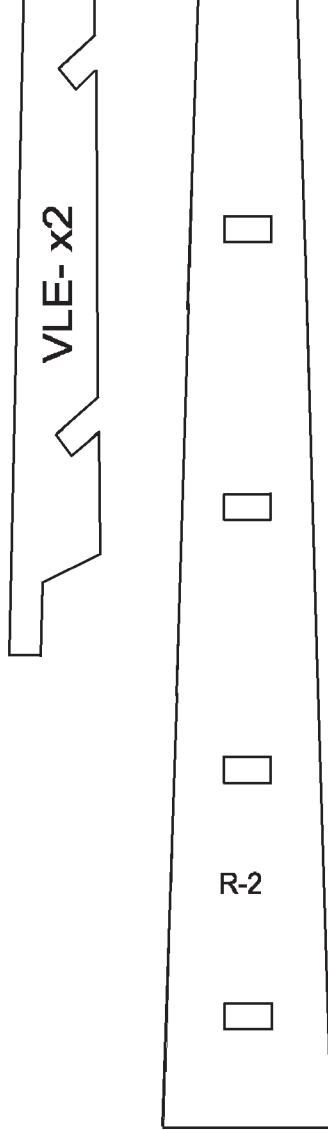
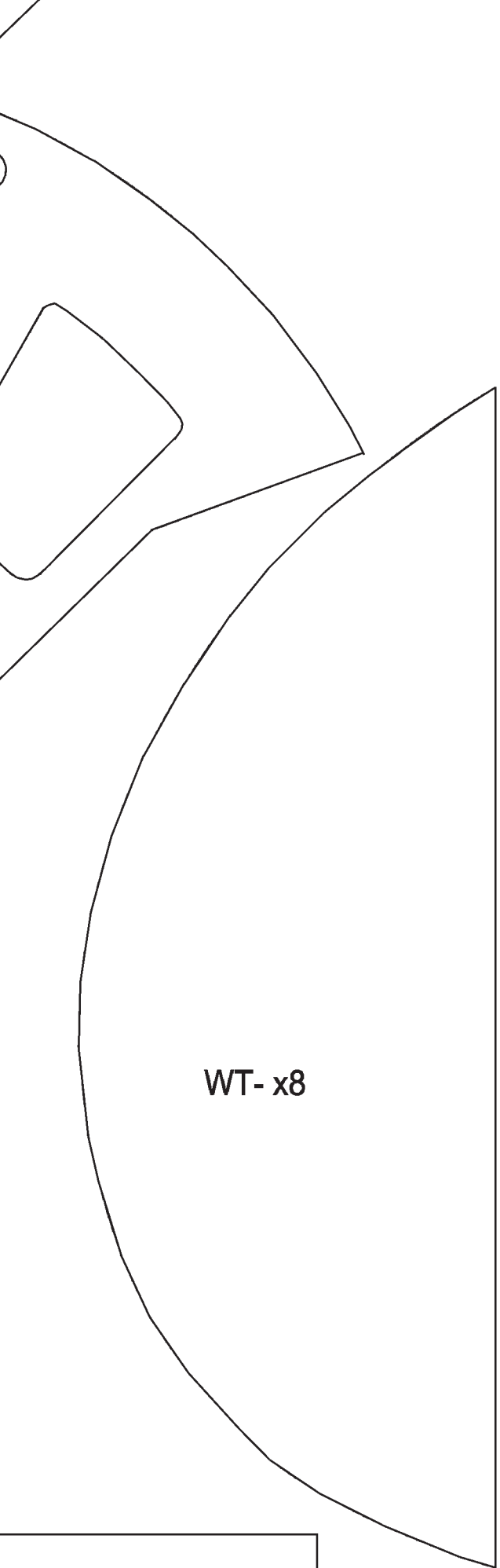

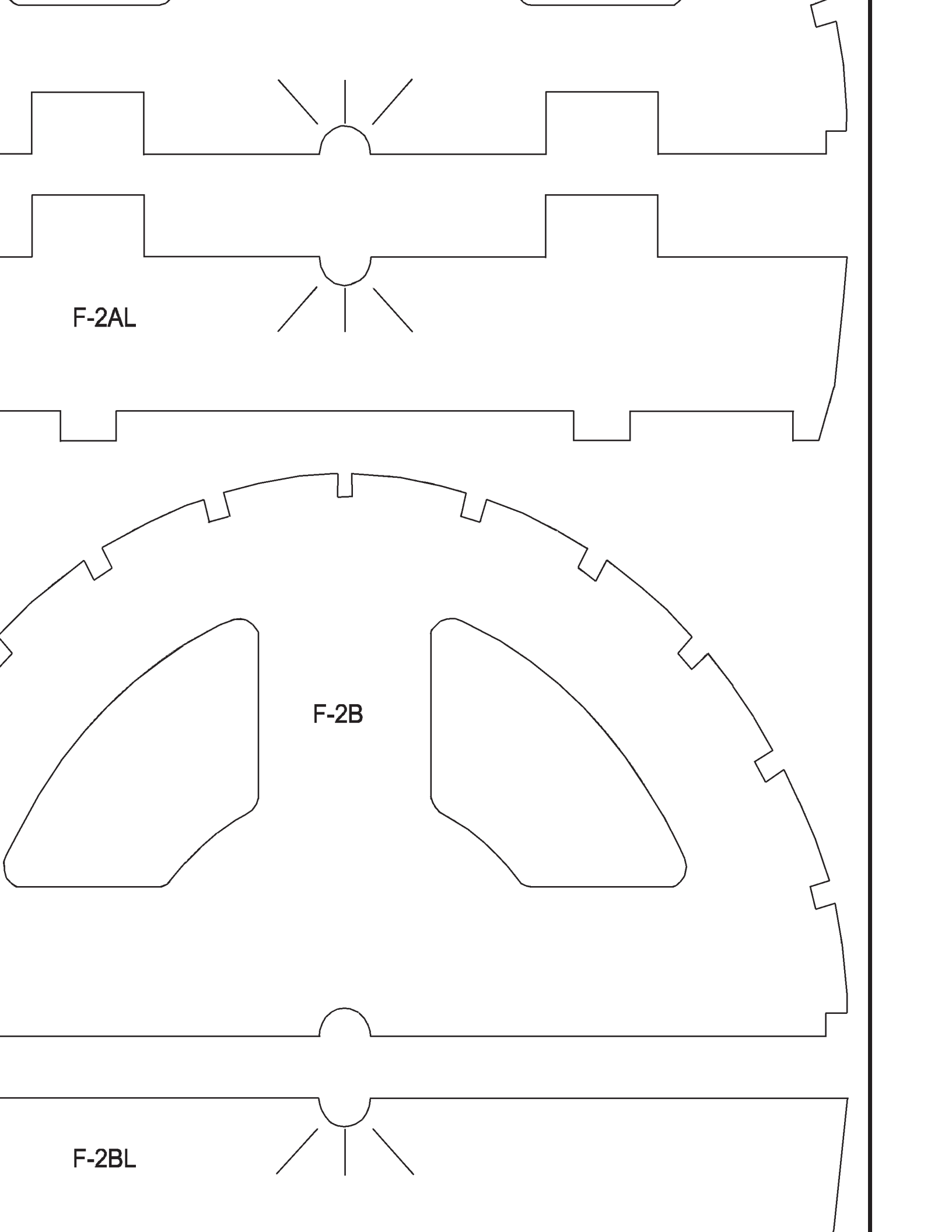

F-2AL

F-2B

F-2BL

LEADING ED

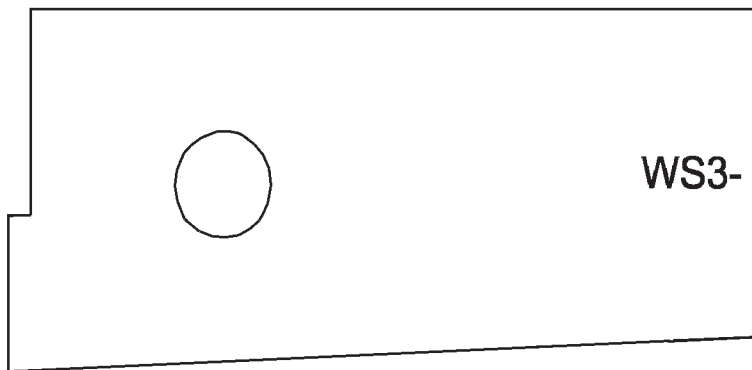

WS3-

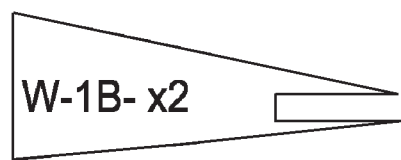

W-1B- x2

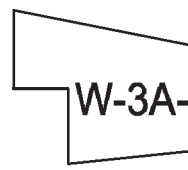

W-3A-

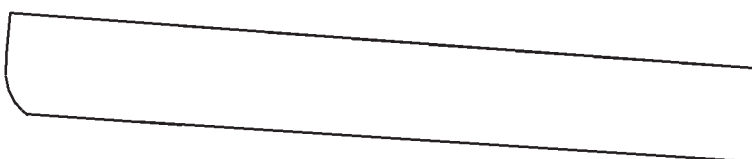

EDGE OUTER x2

3- x2

3A- x2

COCKPIT SIDE- x2

K-3

WS OUTER- x2

COWL RING

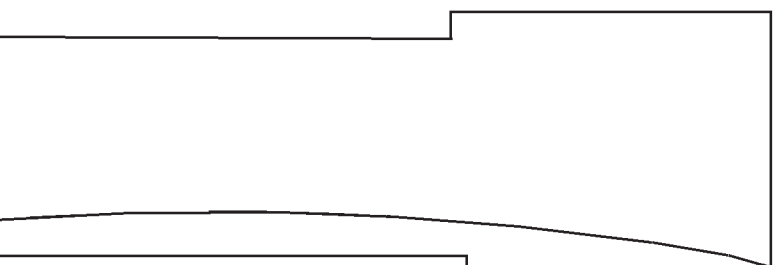

RING ALIGNMENT TOOL

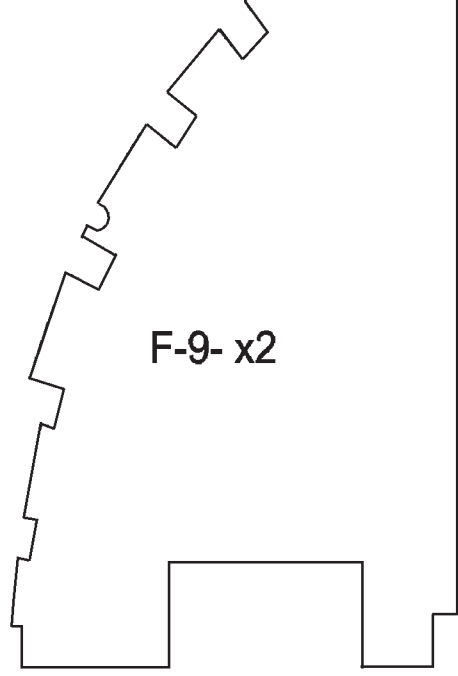

F-9- x2

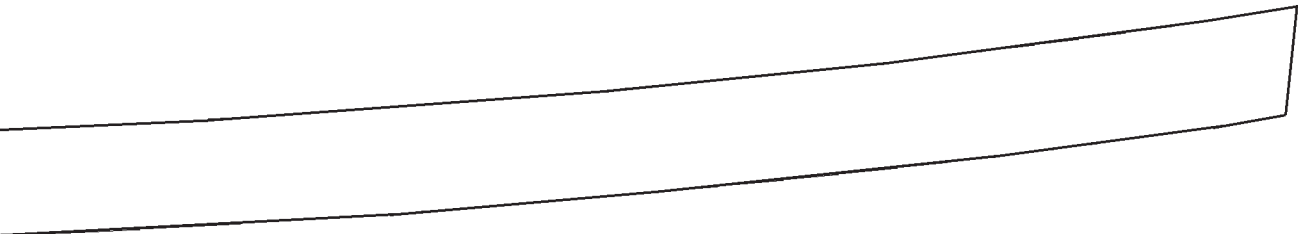

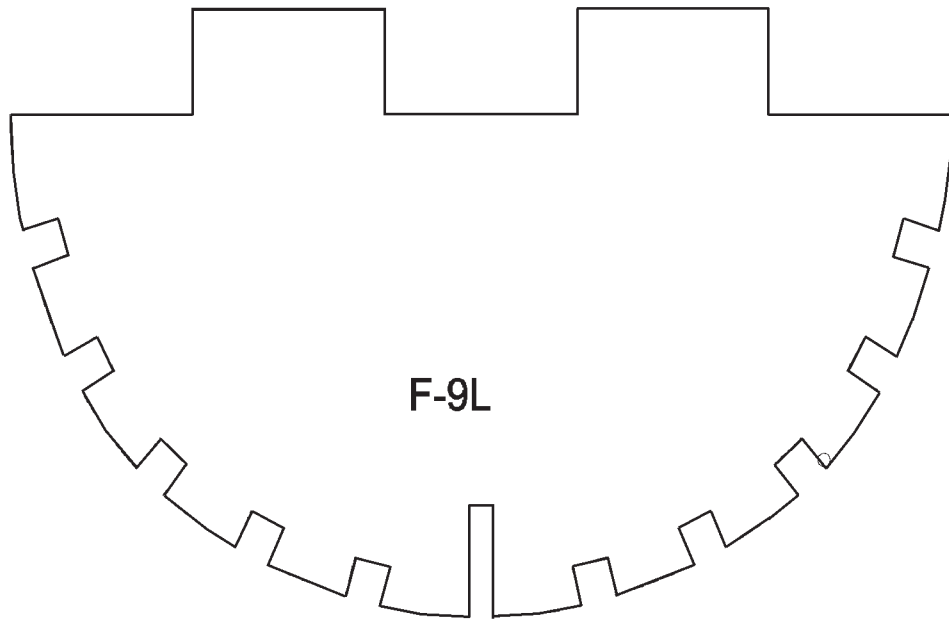

F-9L

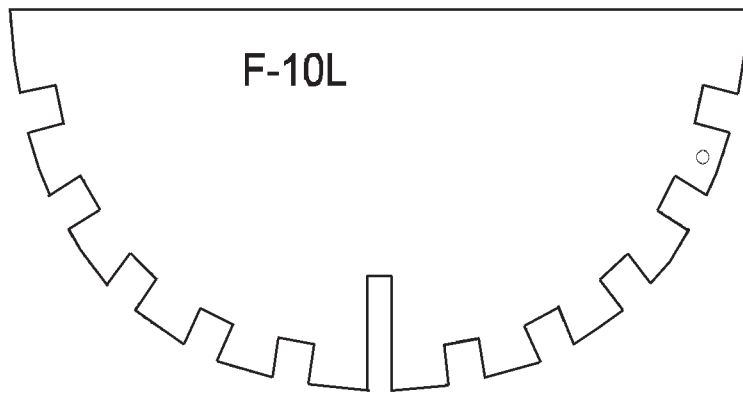

F-10L



TOP- x4

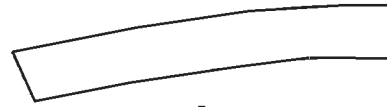

SIDE - x2 E



+30 x2 Eac



+60 x2 EA



x4

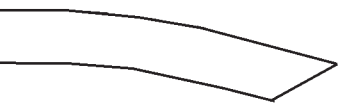

2 EACH



Each



EACH

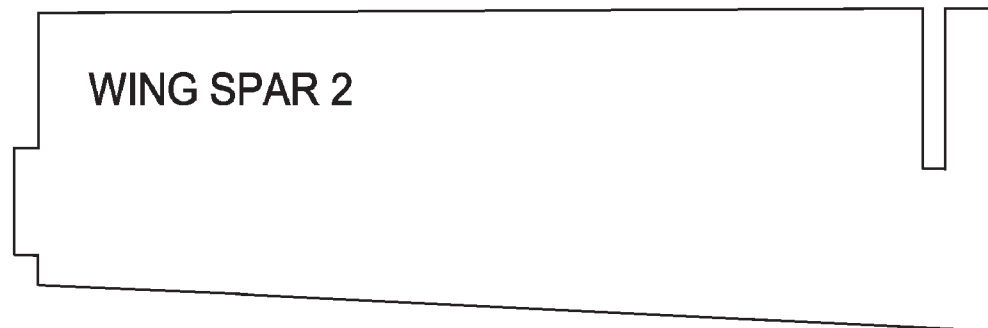
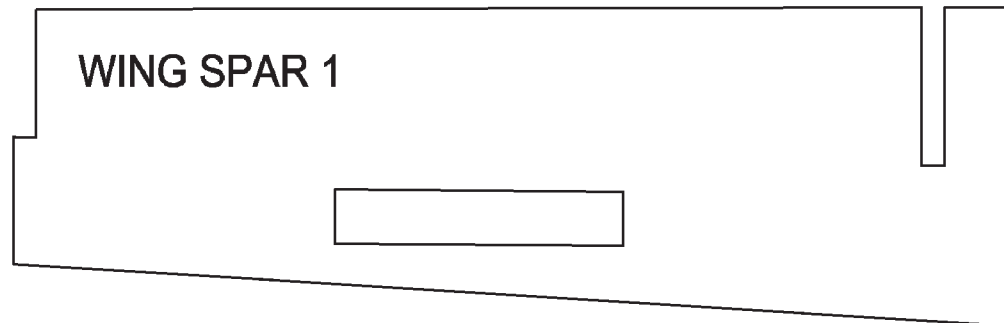
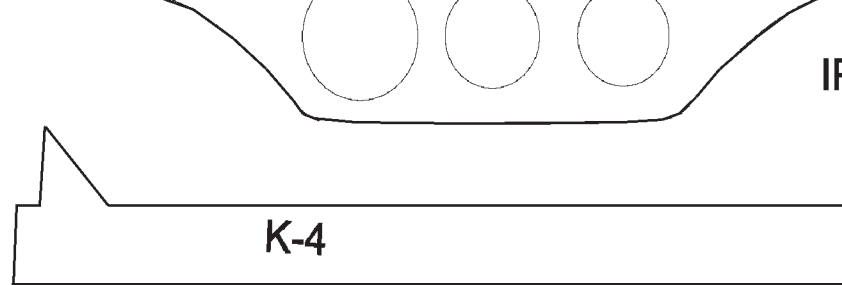

IP

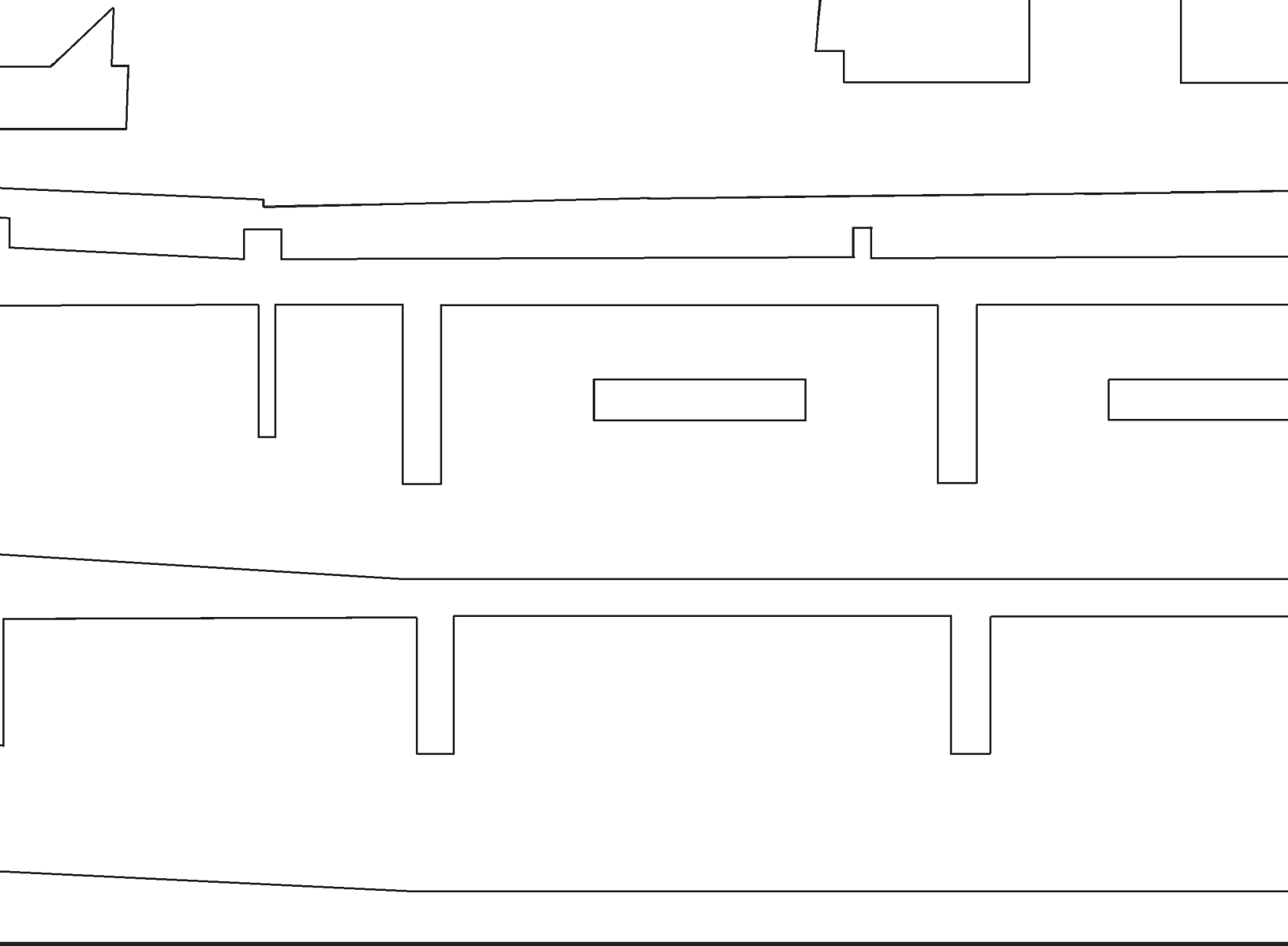

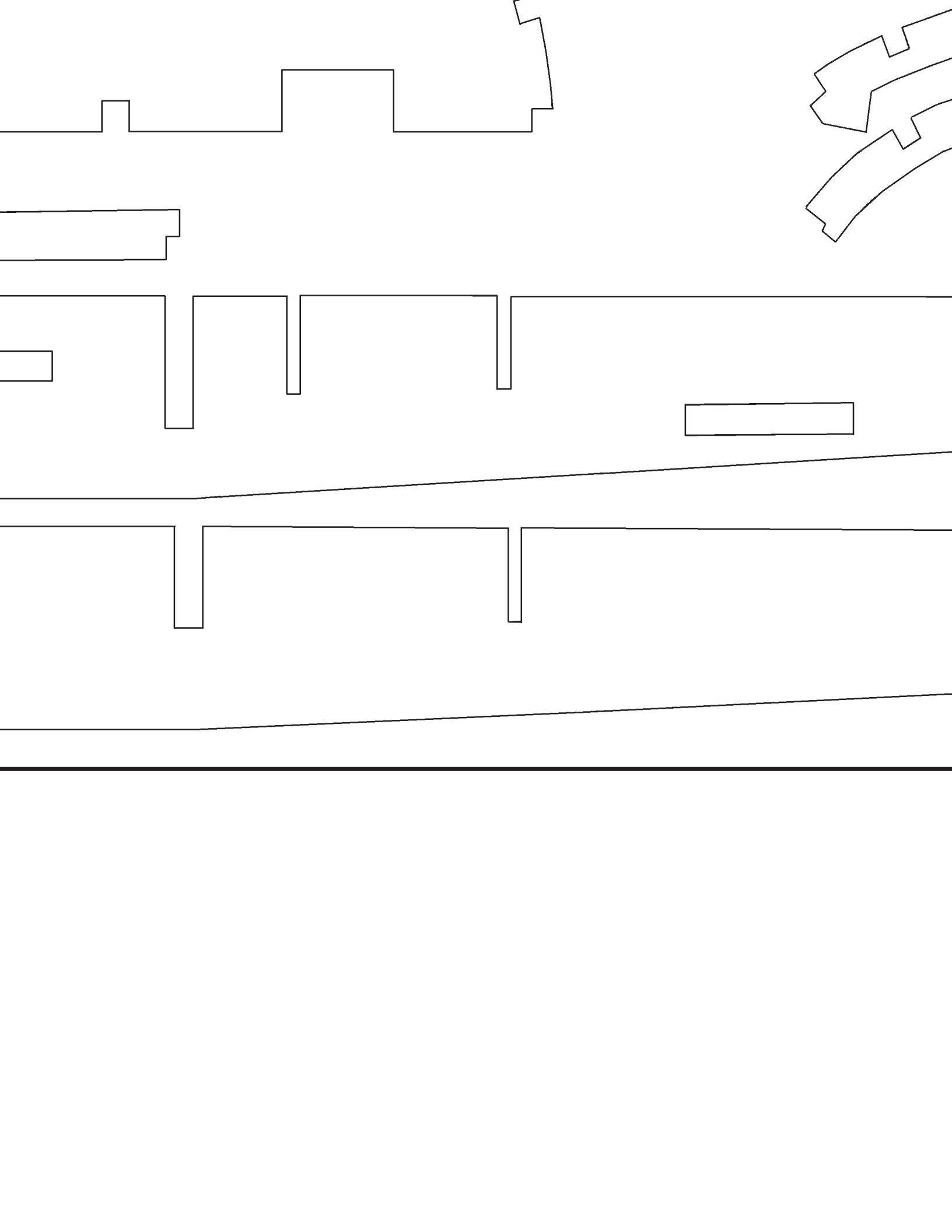

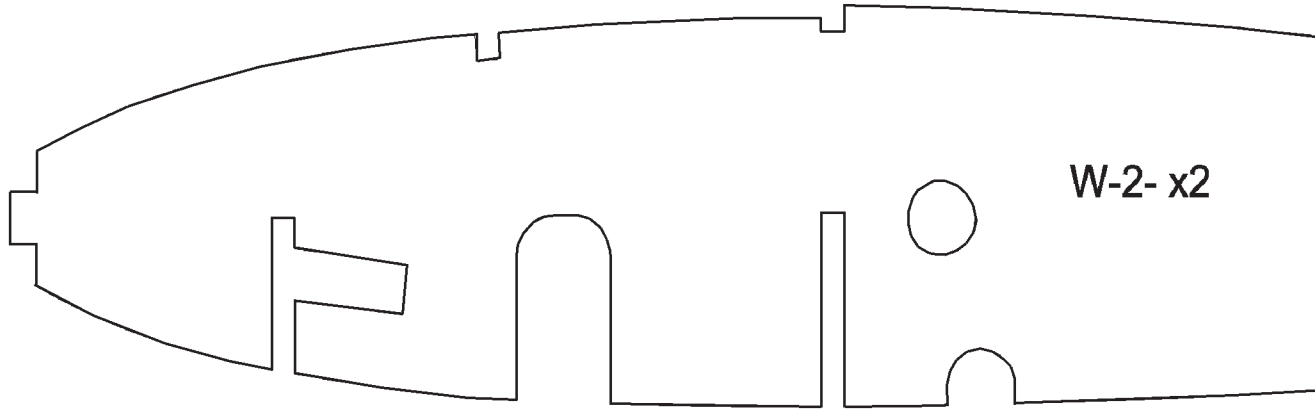
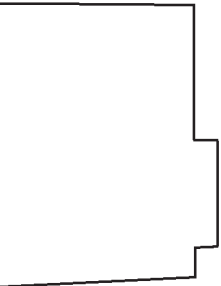
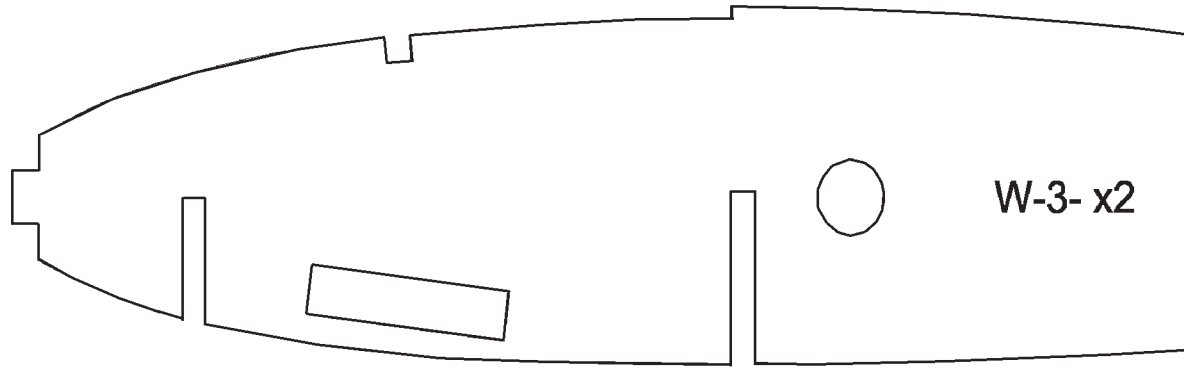
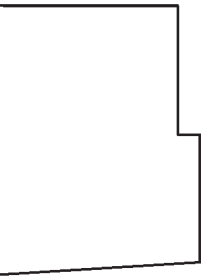
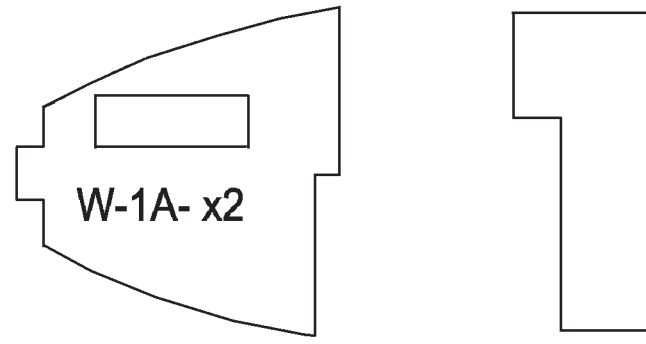
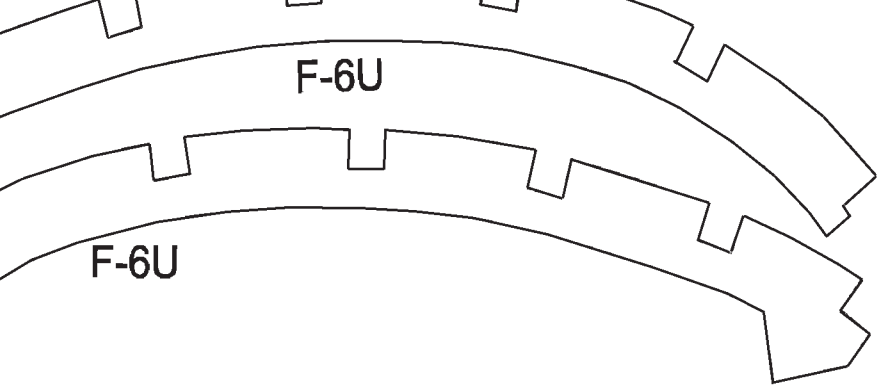

WMP-2- x2

GEAR DOOR 2
MOUNTING TAB

GDMT- x4

CP-3

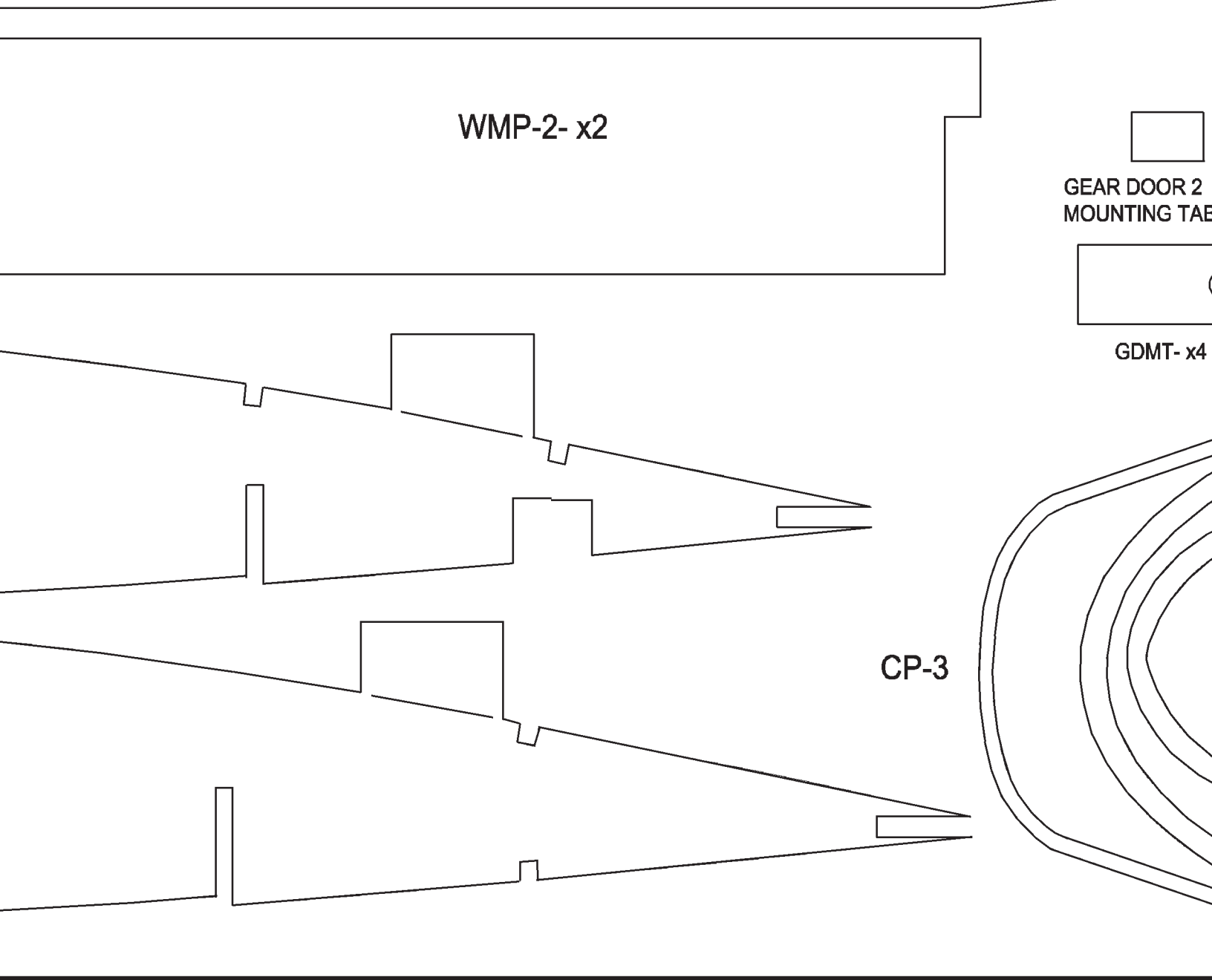



R 2
TABS- x8



x4



WMP-4

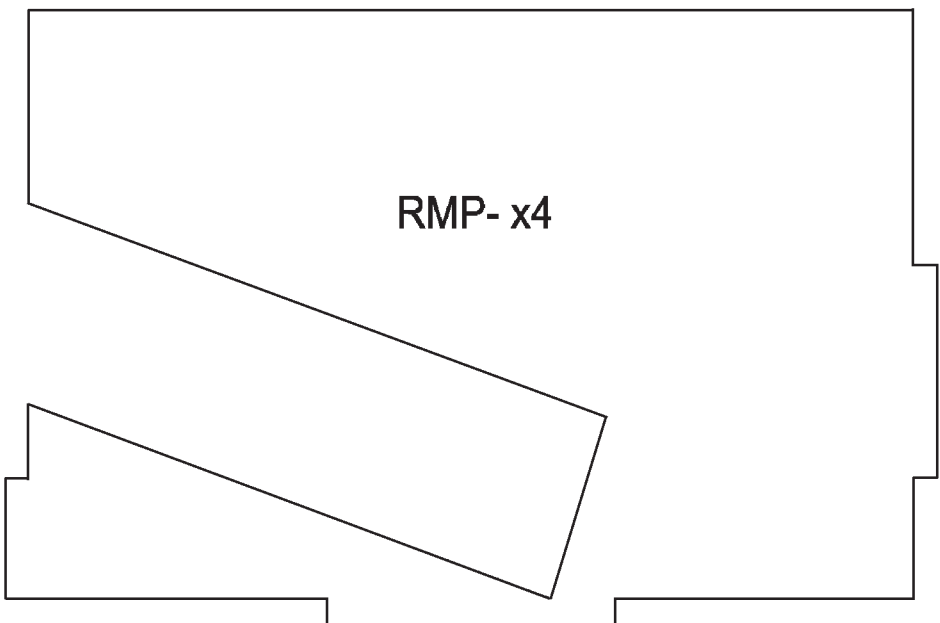

RMP- x4

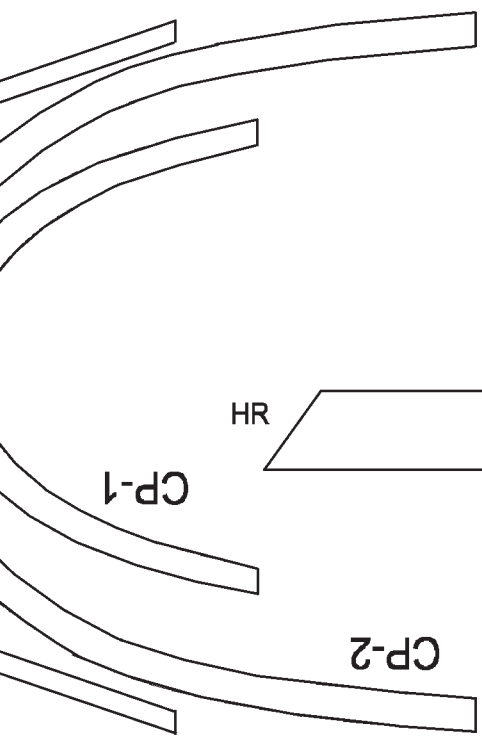

CP-1

CP-2

HR

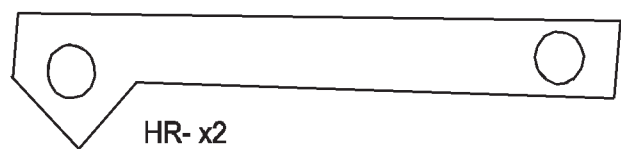

HR- x2

V-1- x2

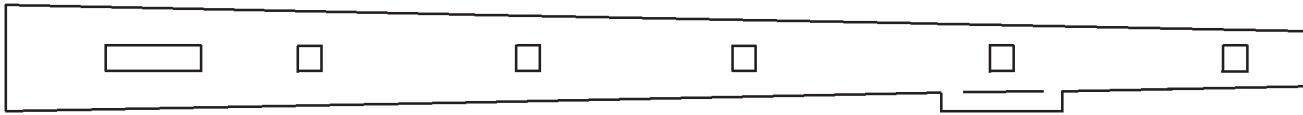

E-1- x2

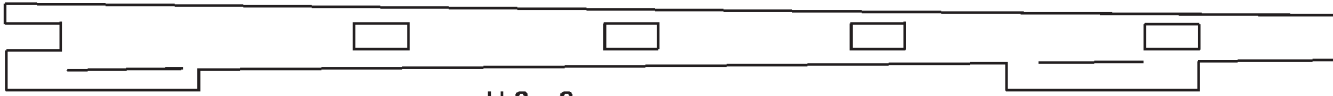

H-2- x2

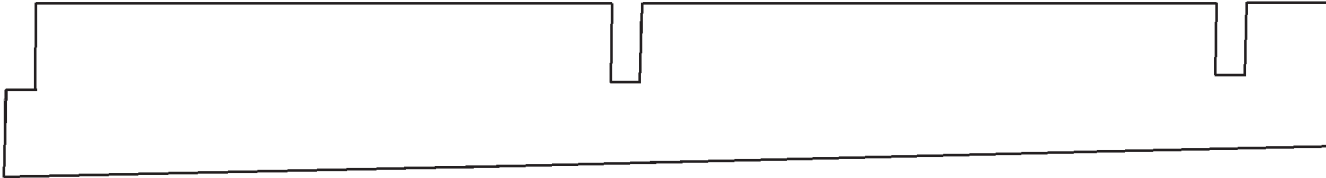

REAR SPAR- x2

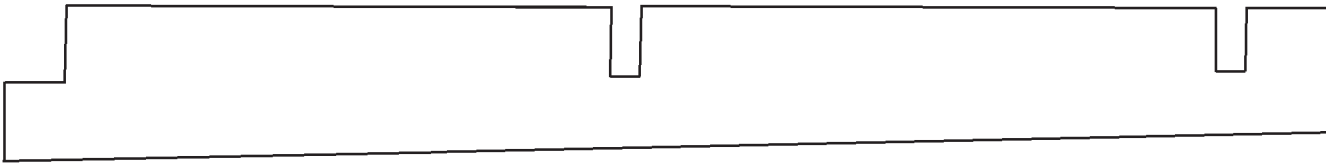

ALE LEADING EDGE- x2



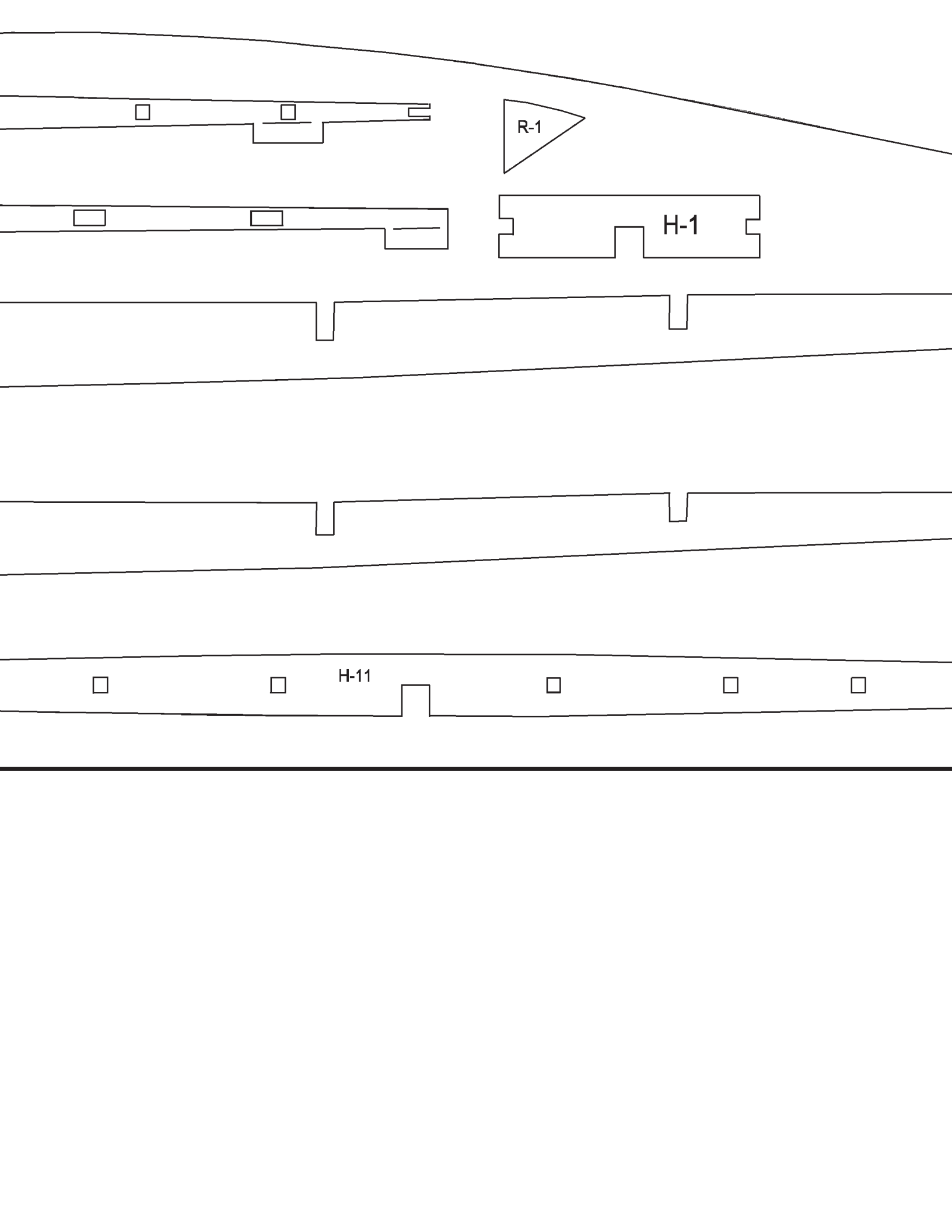

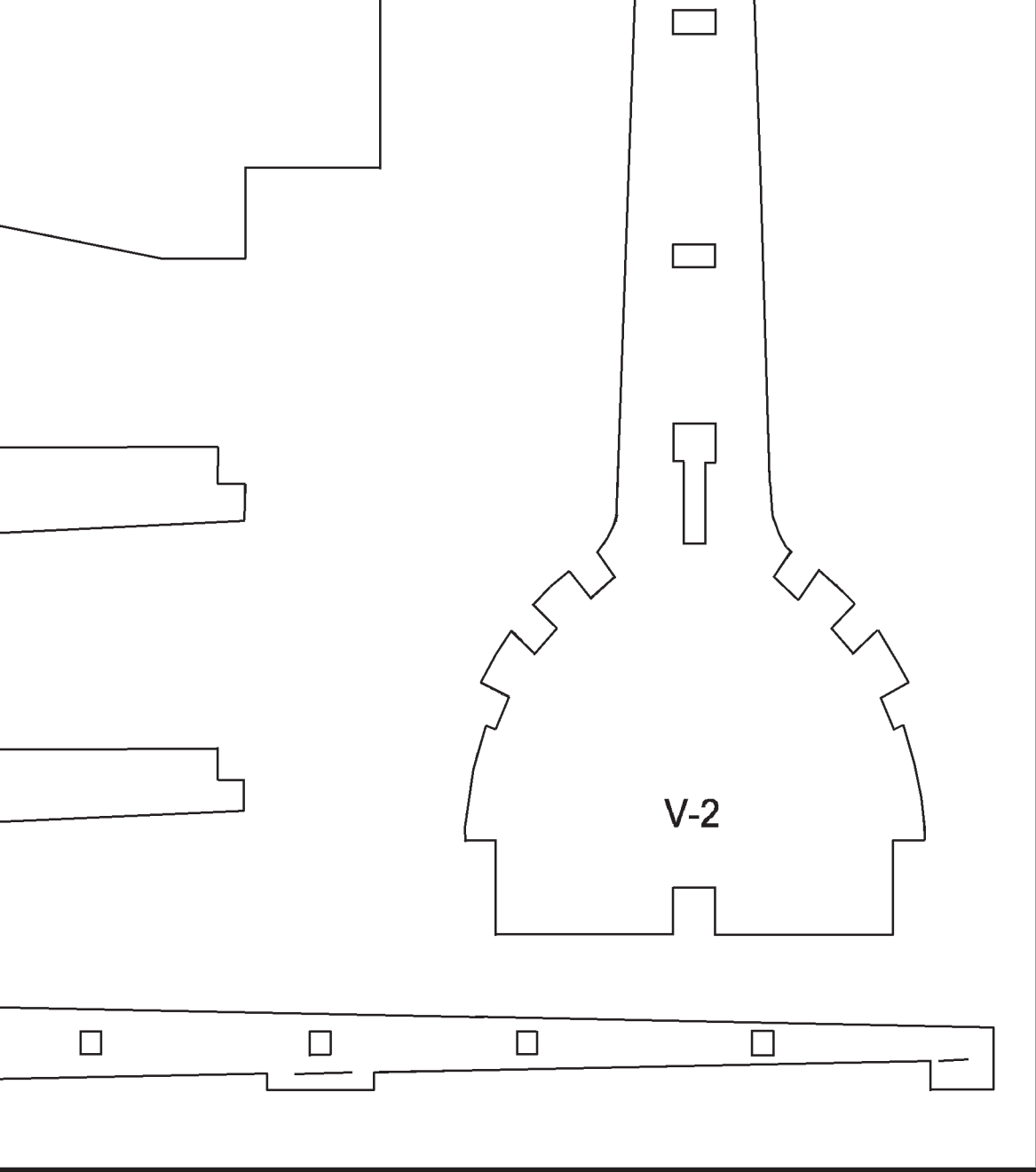

1-1

DES
ALL

PLAN

0
L

16 RATA

Copyright 2018  and **ModelAviation**
ACADEMY OF MODEL AERONAUTICS
Bringing Modelers Together

Copying for resale of this drawing without
the written approval or consent of AMA
is expressly prohibited.

SIGNED BY DEREK MICKO
ALL RIGHTS RESERVED

PART 4 OF 4- PART SHEET Plan No. 1110

