

REINFORCE DIHEDRAL BREAKS WITH 1-OZ. GLASS CLOTH
COVERING: 1/3- TO 1/2-MIL MYLAR, DOCULAM, OR POLYSPAN

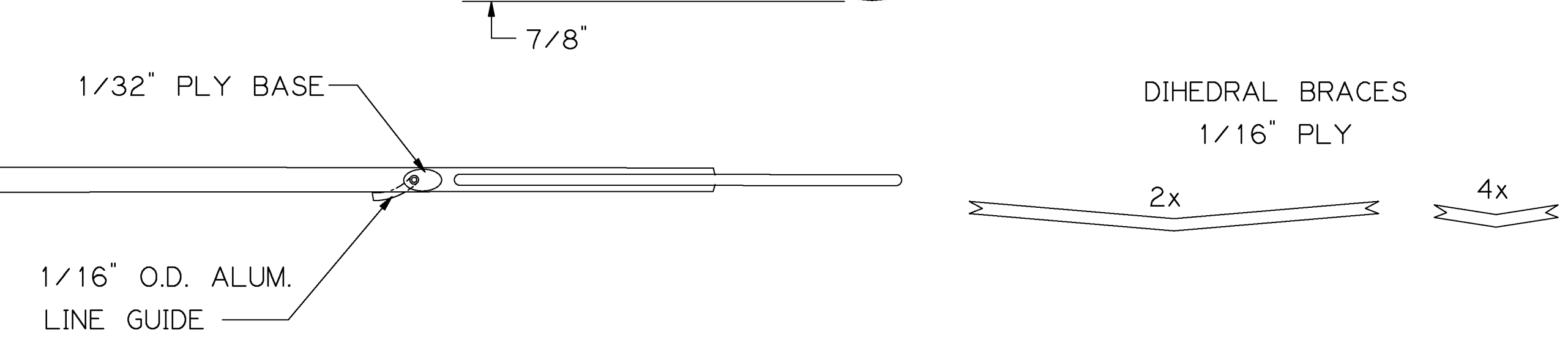
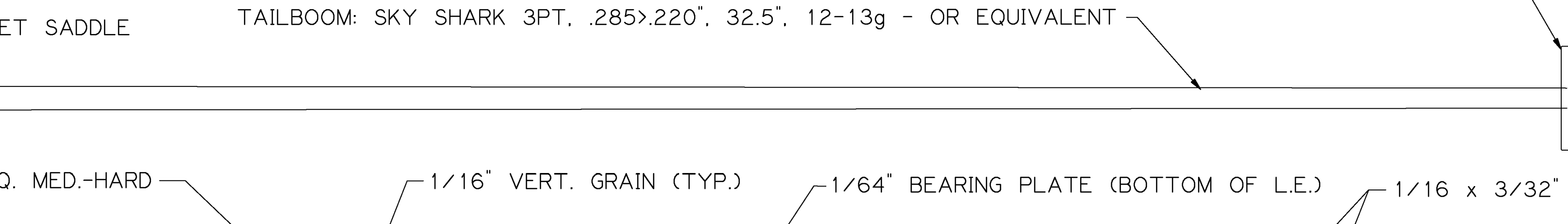
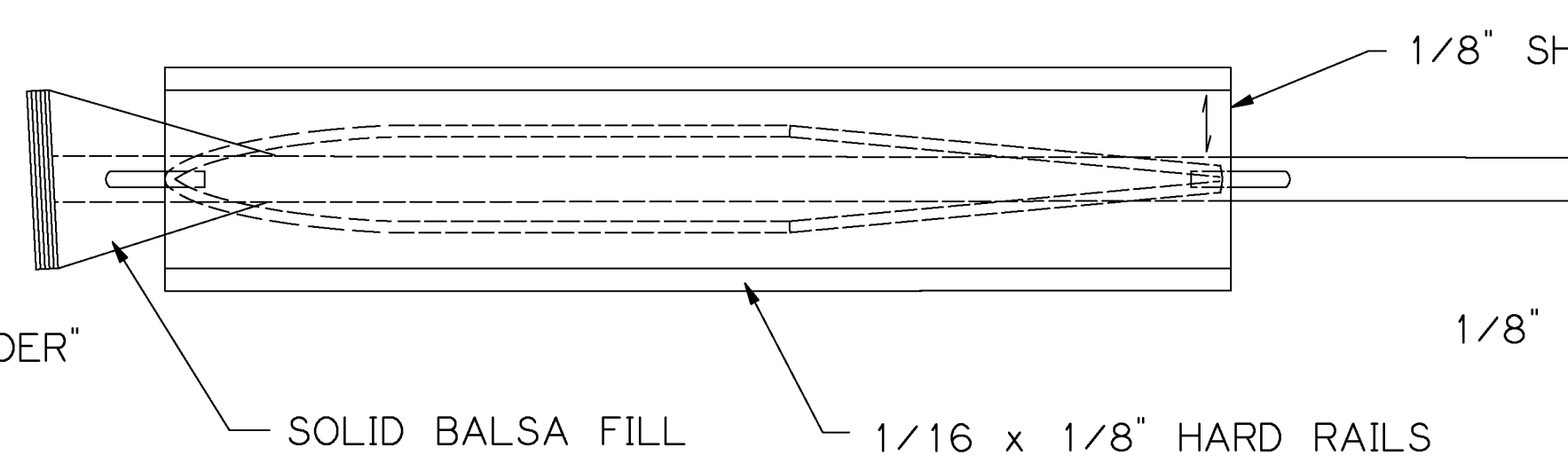
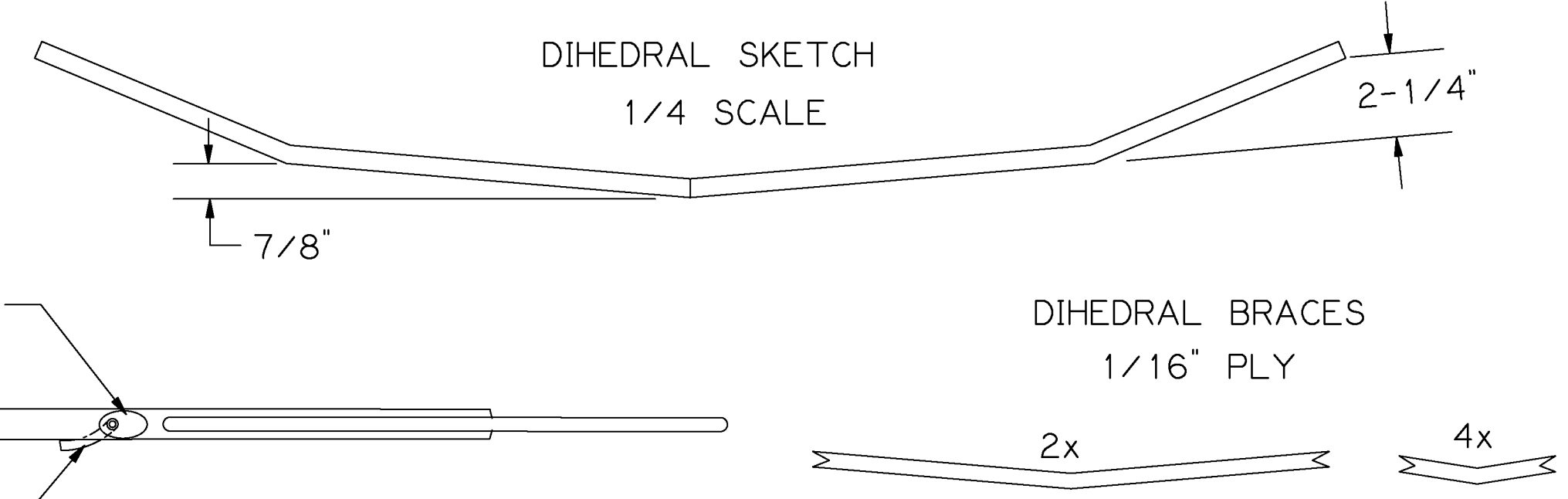

IMPORTANT: SKID PROTECTS BATTERY ON LANDING. OMISSION OF SKID IS A FIRE HAZARD.

Laser-cut kits of this design are available. Email <ddeloach@comcast.net>

OPTIONAL MACHINED ALUMINUM MOTOR MOUNT FROM TEXASTIMERS.COM - A NICE UPGRADE...STRONGER AND LIGHTER.

COVER PYLON WITH TISSUE OR LIGHT GLASS CLOTH

SECURE MOTOR WITH #1 OR #2 X 1/4" PAN HEAD WOOD SCREWS

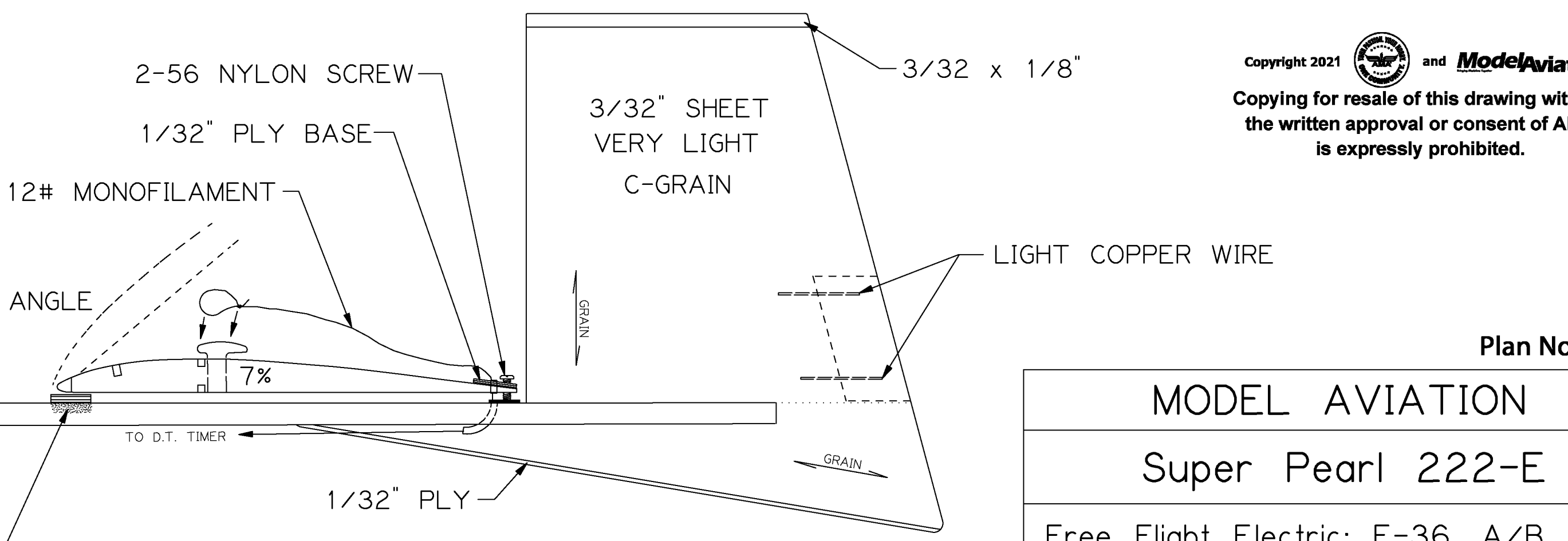
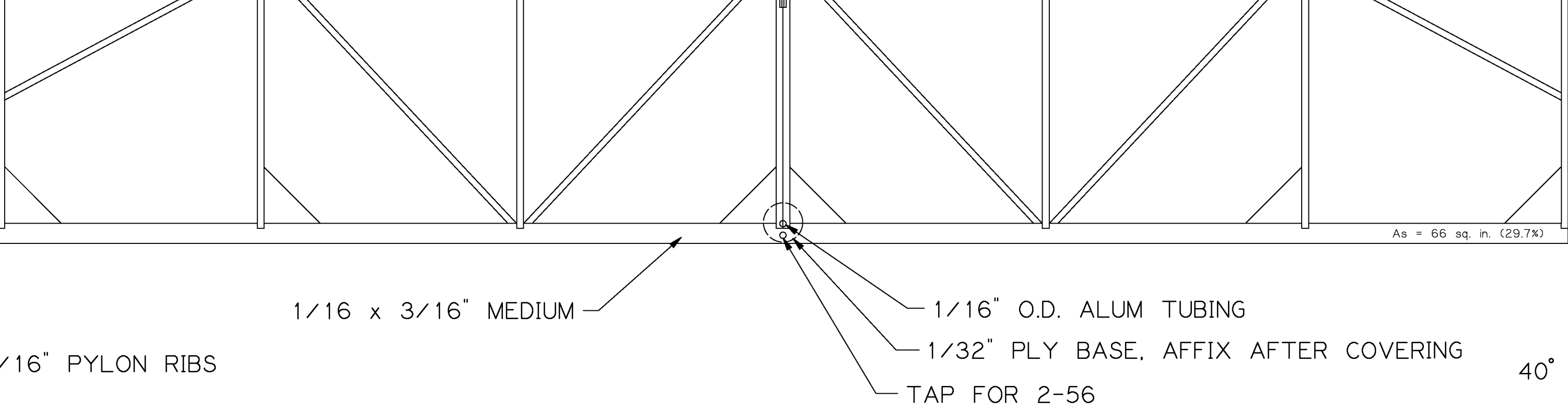
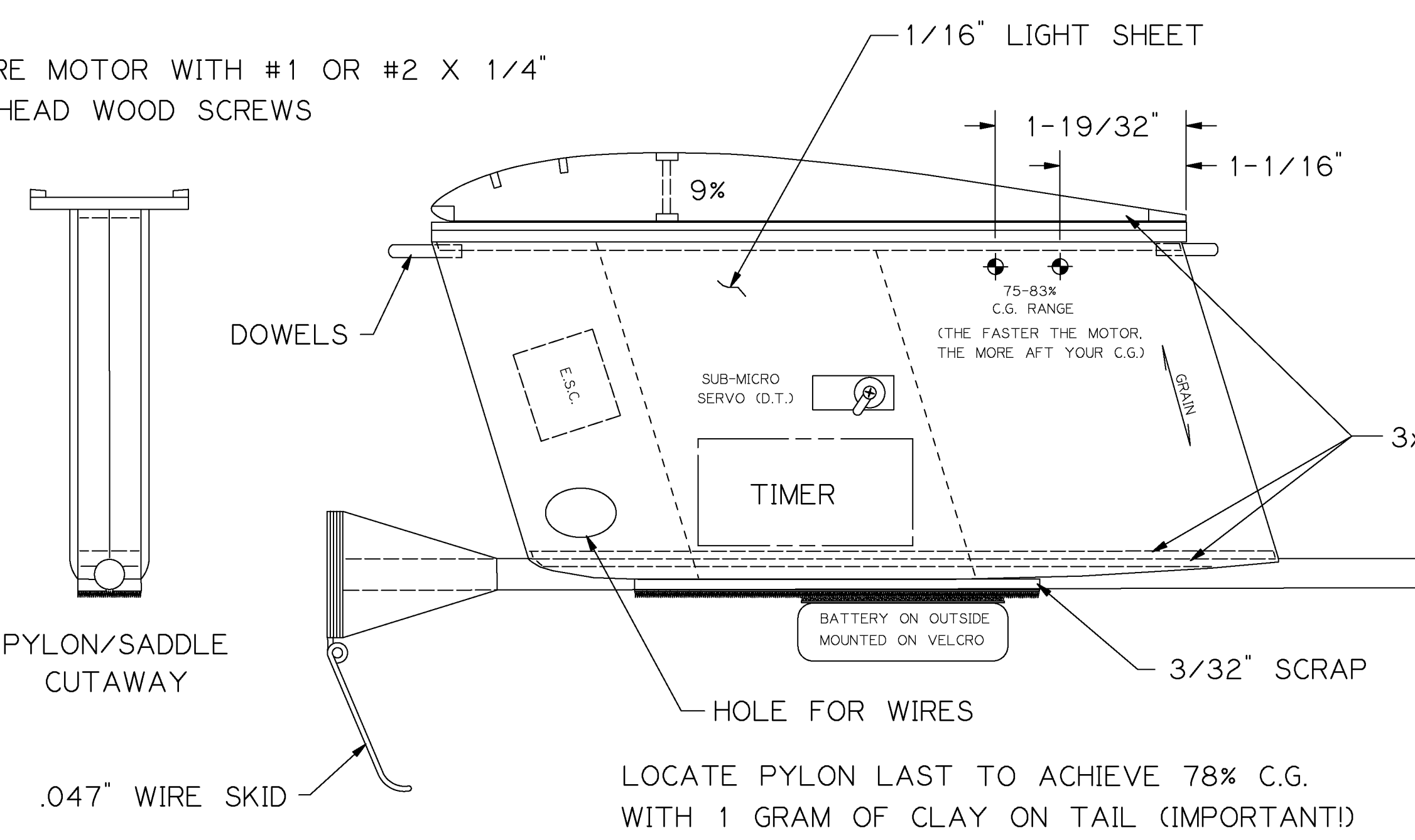

MOTOR: TEXAS "RED MAX" OR 2205-2206 DRONE RACING IN 2500-2950 Kv
BATTERY: THUNDERPOWER, GAONENG, OR TURNIGY, 300-500mAh, 2S, 65-80C
SPEED CONTROL: 12A MINIMUM, 20-25A FOR THE STRONGEST MOTORS, BRAKE "ON"
PROP: 7.5x4 FOLDER AND HUB FROM TEXASTIMERS.COM, OR APC 6x6E OR 7x6E
TIMER: FROM WWW.STARLINK-FLITETECH.COM OR WWW.TEXASTIMERS.COM

LOCATE PYLON LAST TO ACHIEVE 78% C.G. WITH 1 GRAM OF CLAY ON TAIL (IMPORTANT!)

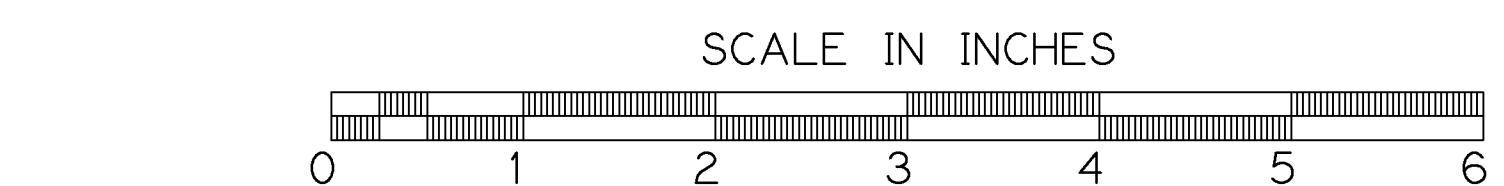

Copyright 2021 and Model Aviation
Copying for resale of this drawing without the written approval or consent of AMA is expressly prohibited.

Plan No. 1126

MODEL AVIATION
Super Pearl 222-E
Free Flight Electric: E-36, A/B, F1S
By Don DeLoach - March, 2021
Outrunner motor and 2-cell Li-Poly Wing Span: 35-3/8" projected