



# 3/32" Balsa

# 1/8" LITE PLY

## FUSE PARTS

## WING PARTS

## TAIL PARTS

GRAIN DIRECTION

GRAIN DIRECTION

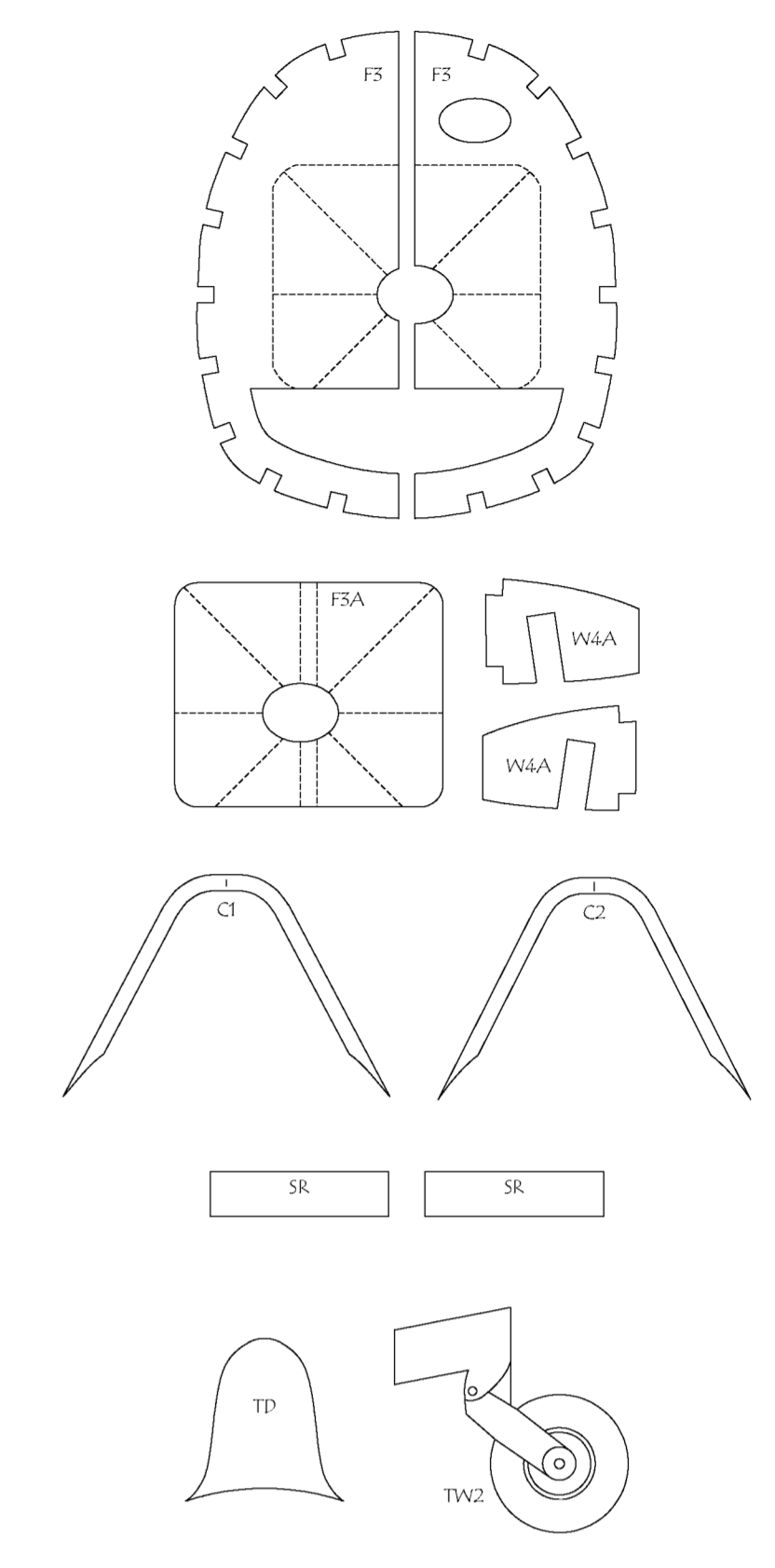
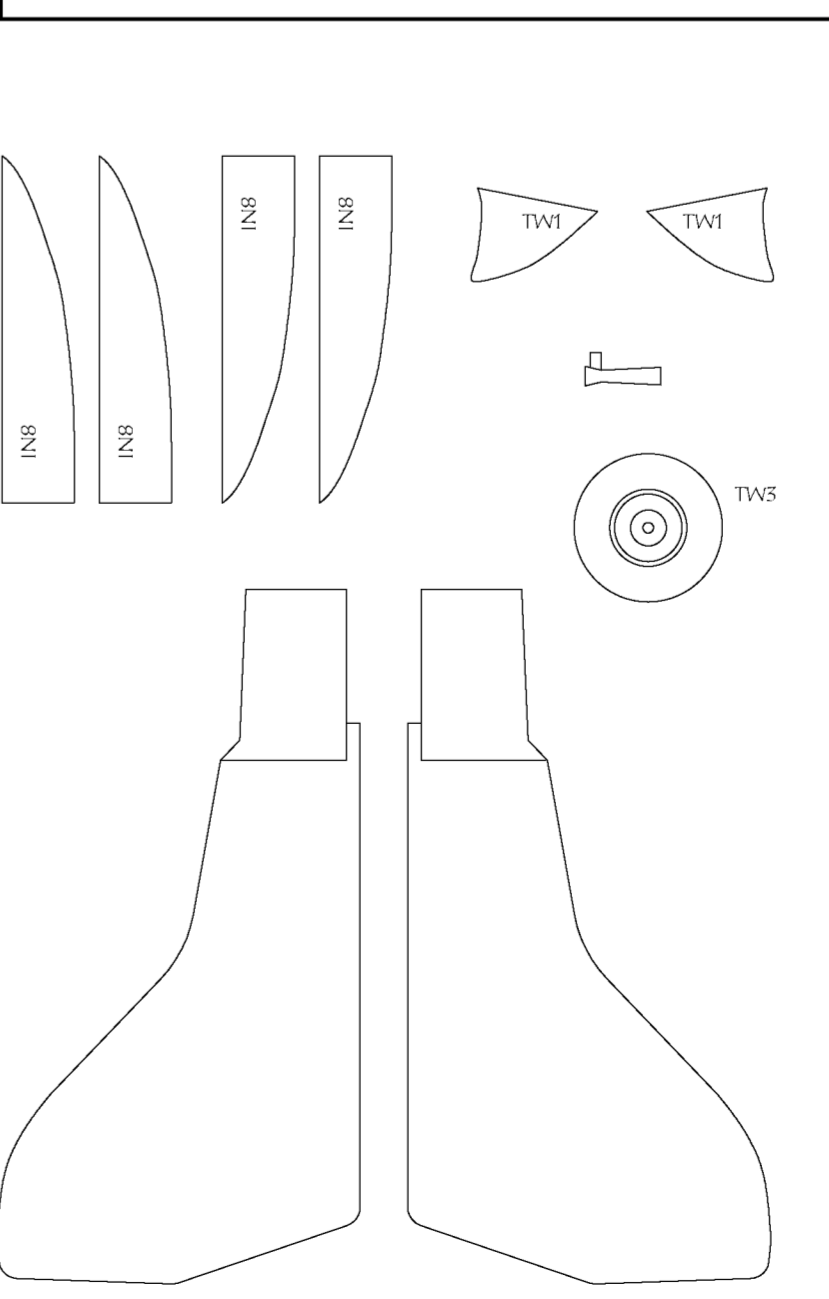
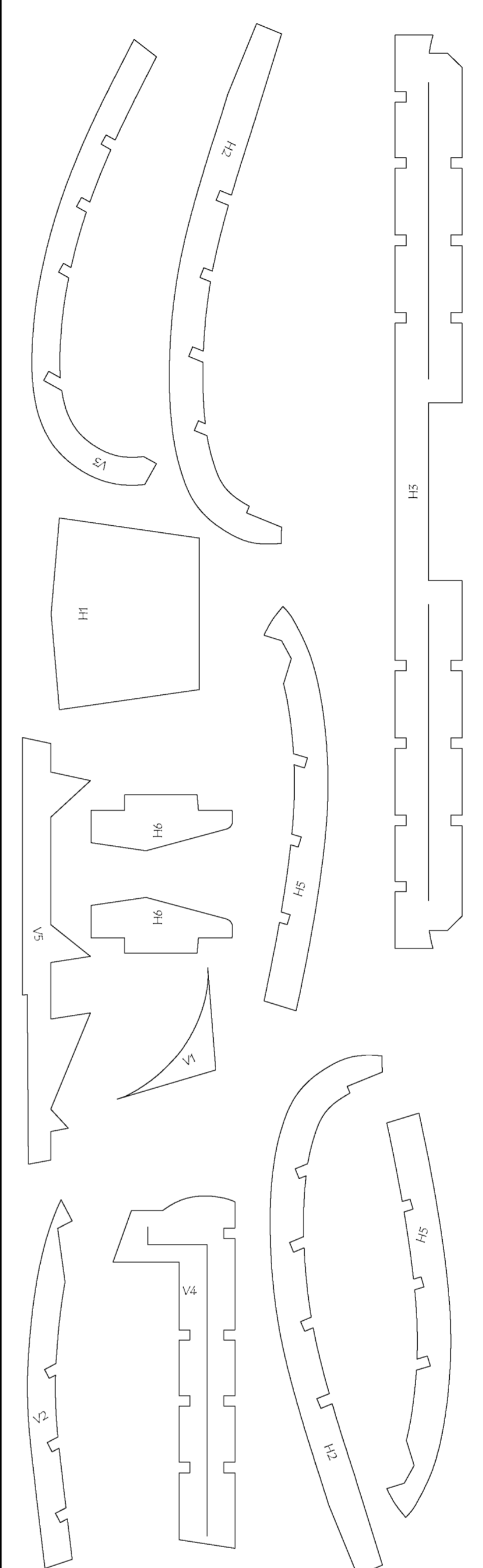
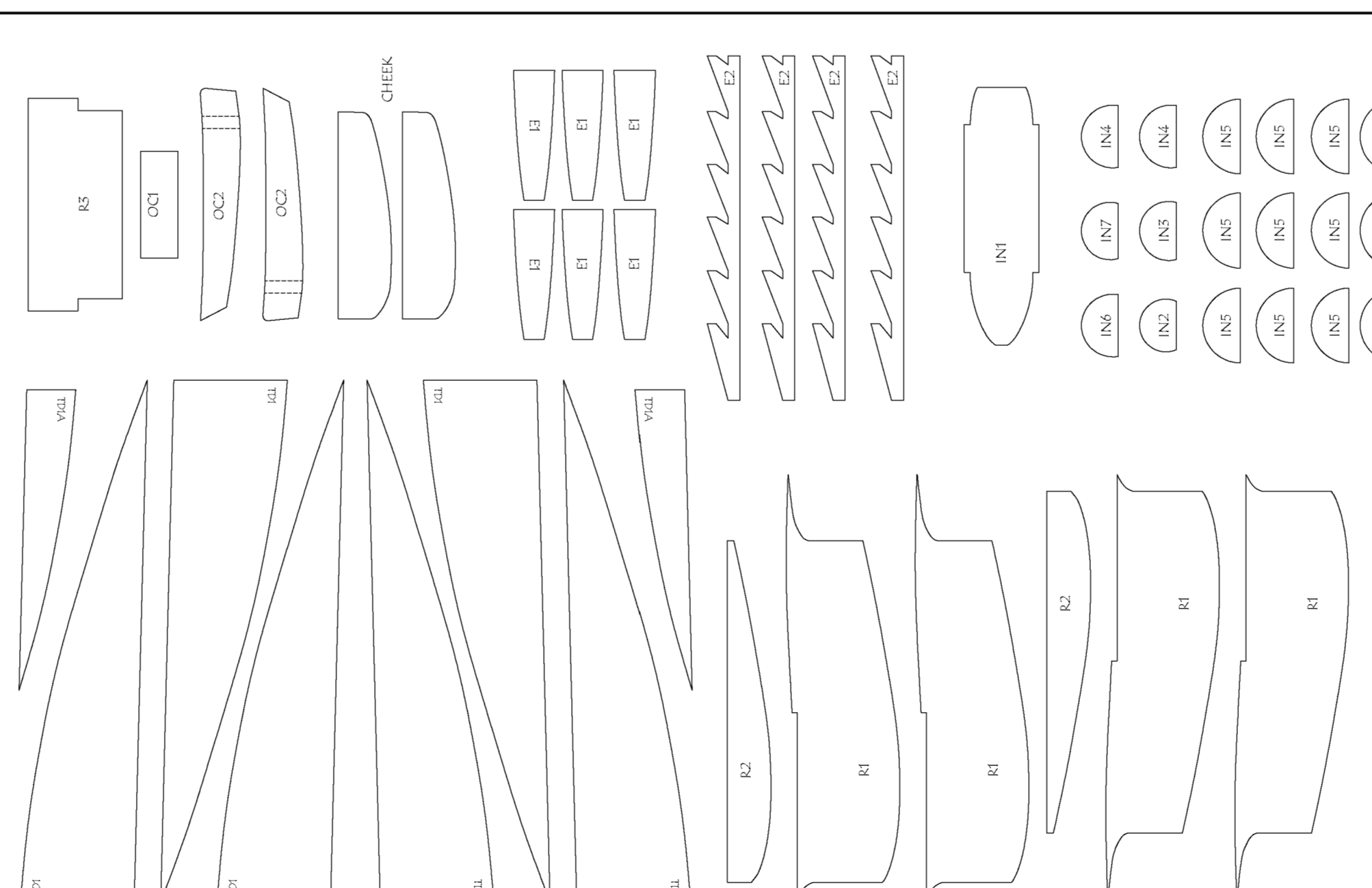
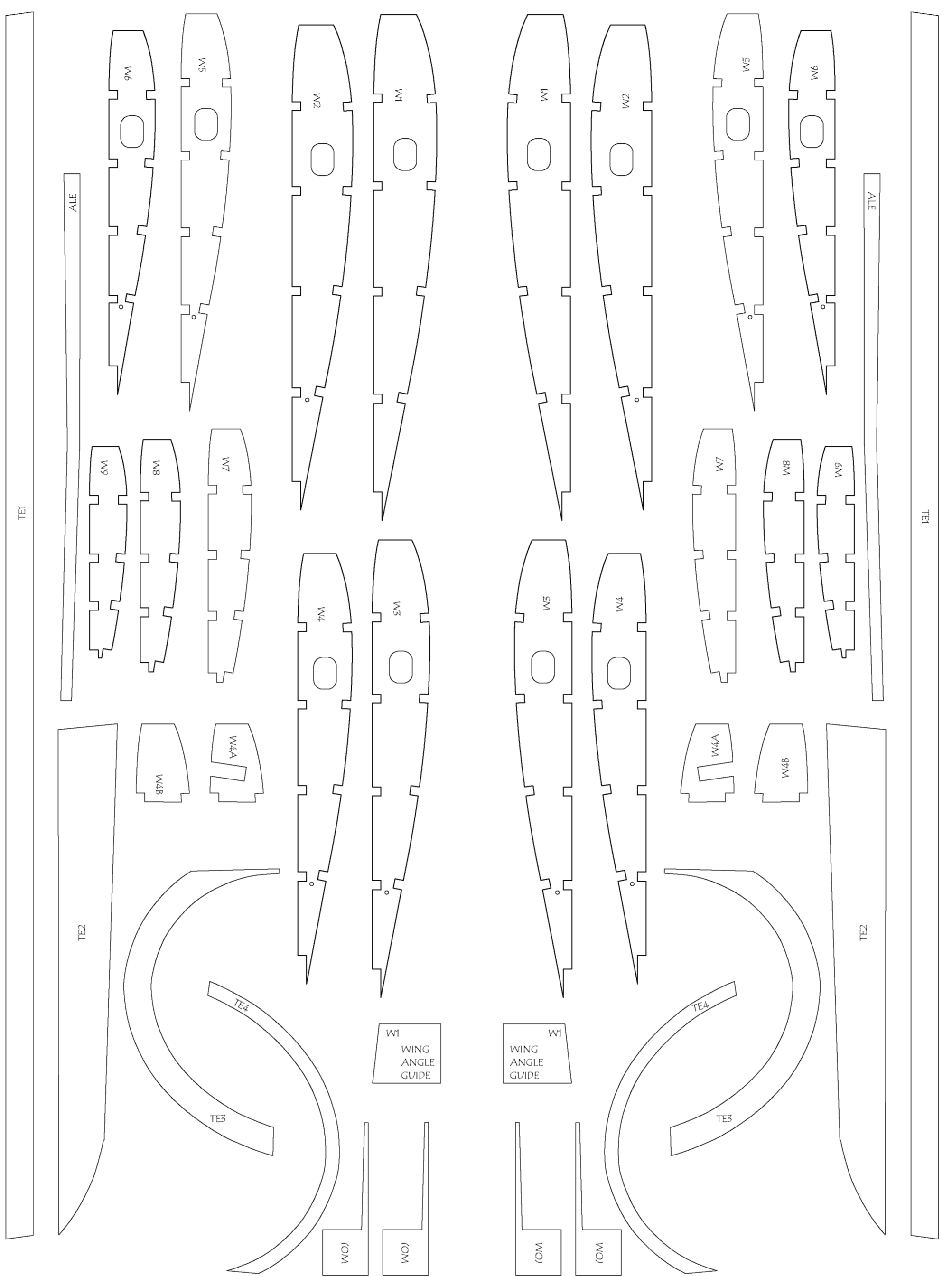
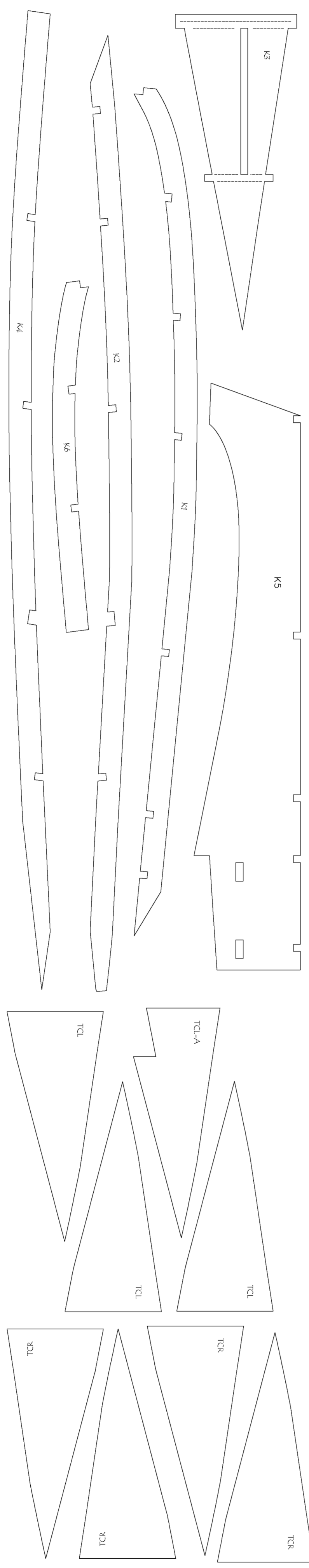
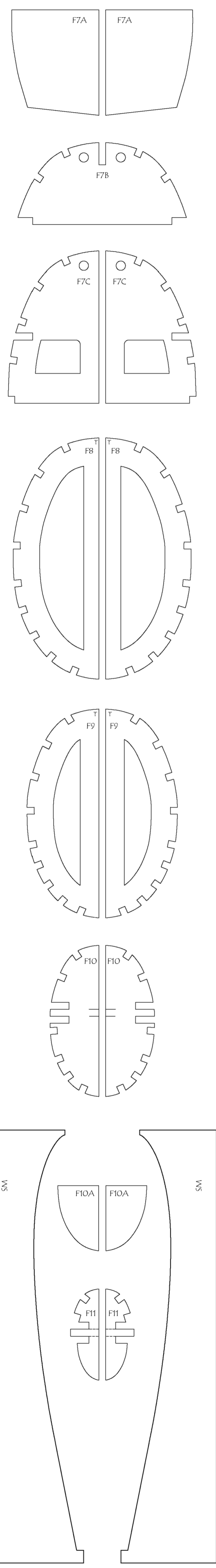
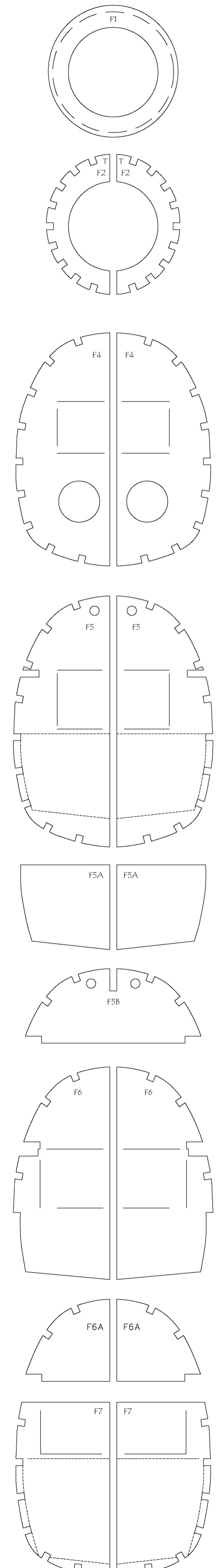

### TEMPLATES

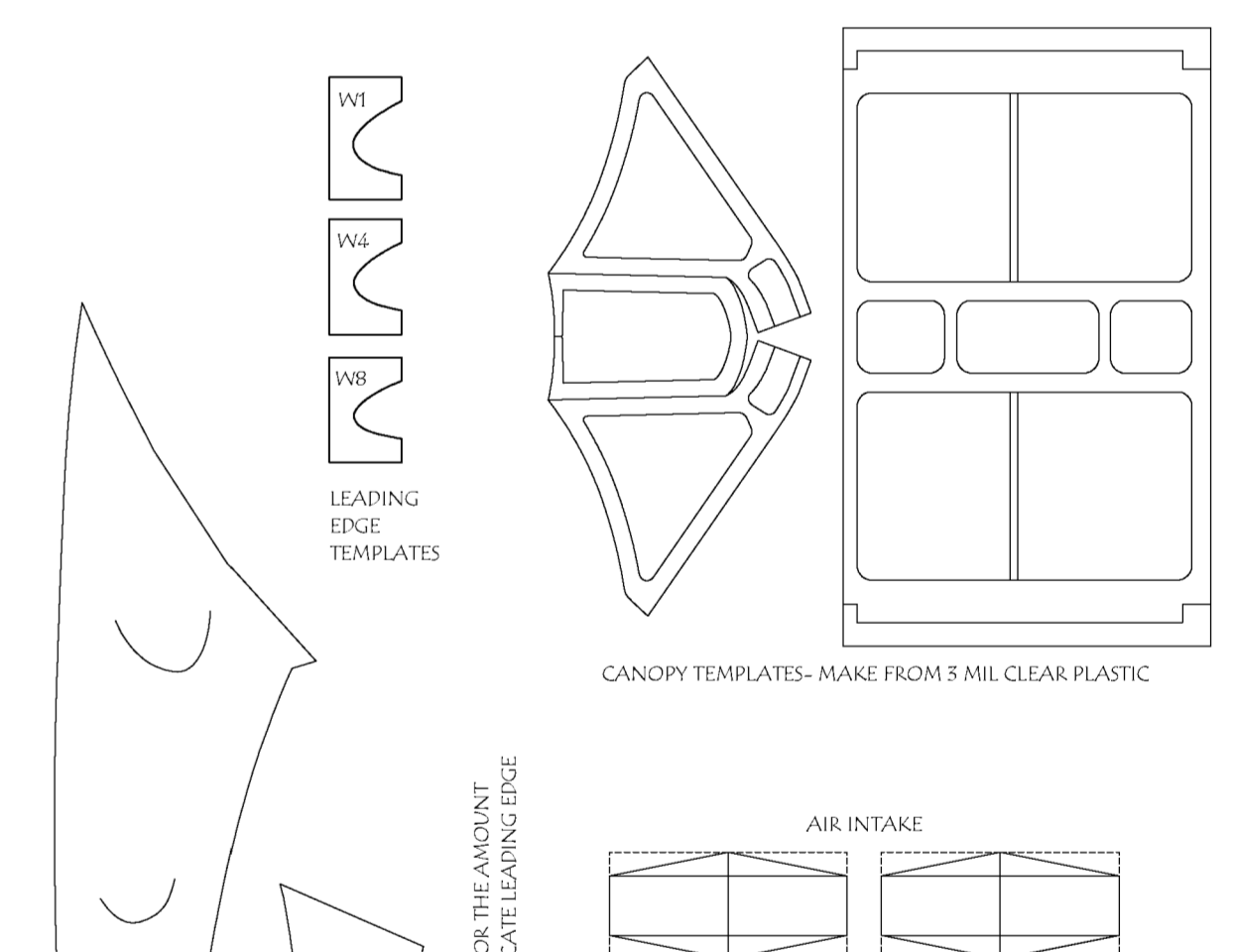

LEADING EDGE TEMPLATES

CANOPY TEMPLATES- MAKE FROM 5 MIL CLEAR PLASTIC

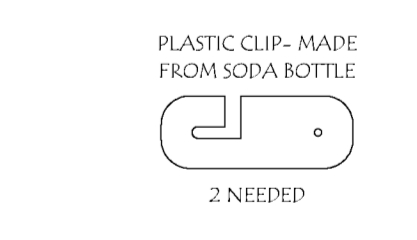
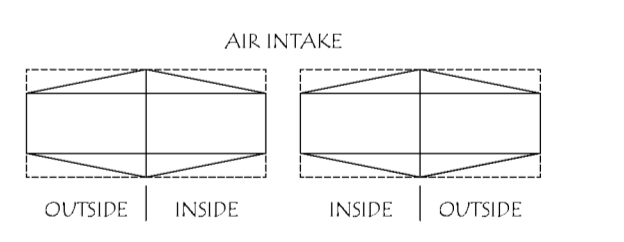

PRACTICE TEMPLATE- NOTE THE MARKINGS FOR THE AMOUNT OF CURVE APPLIED. FRONT DASHED LINES INDICATE LEADING EDGE

**MACCHI 202 FOLGORE PARTS SHEET**  
 DESIGNED BY DEREK MICKO-  
 30" WINGSPAN  
 6-9 OUNCES  
 CHANNELS: 4  
 MOTOR: 18-24 GRAM  
 ALL RIGHTS RESERVED  
**Sheet 2 of 2 Plan No. 1132**

