

PLUG-IN GEAR DETAIL

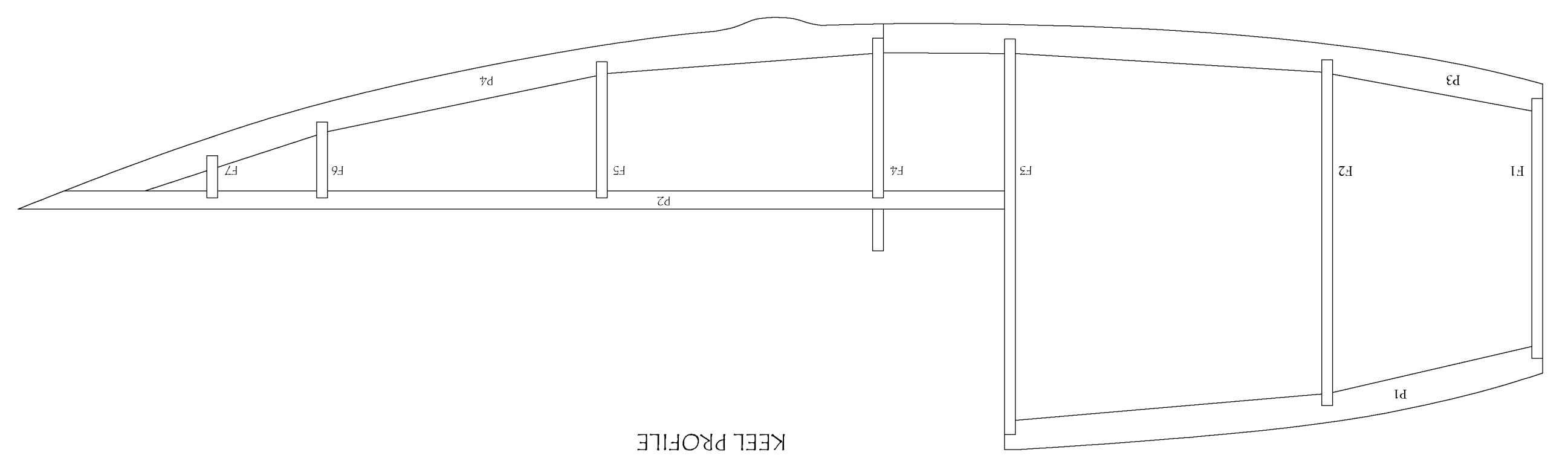

CANOPY HATCH DETAIL

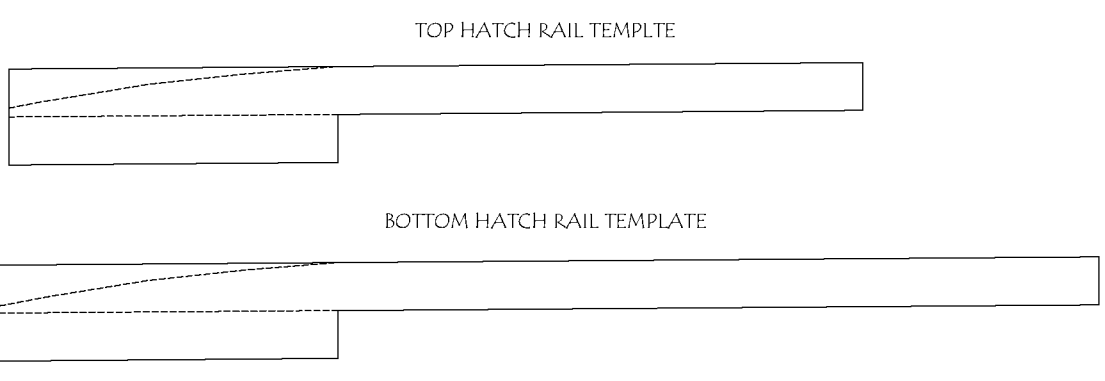
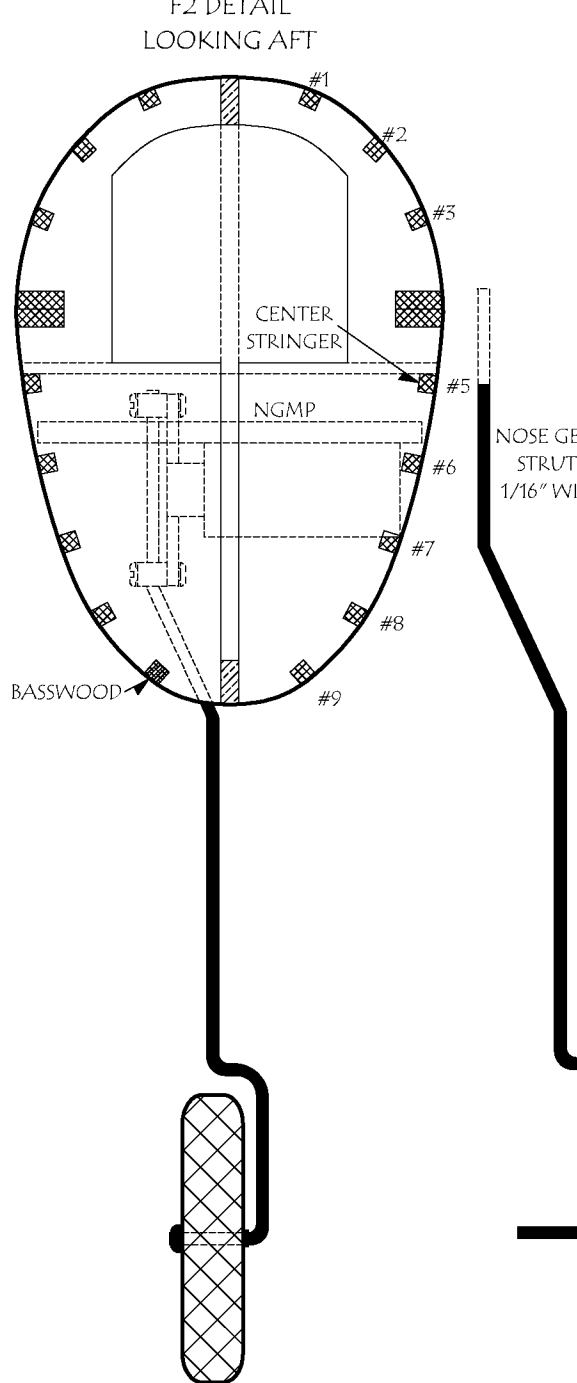
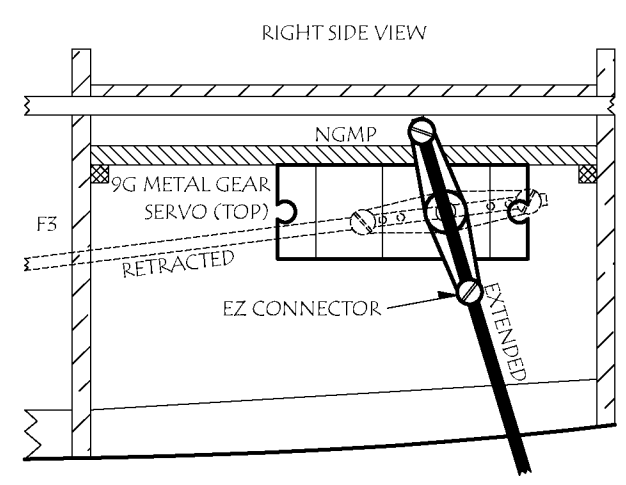
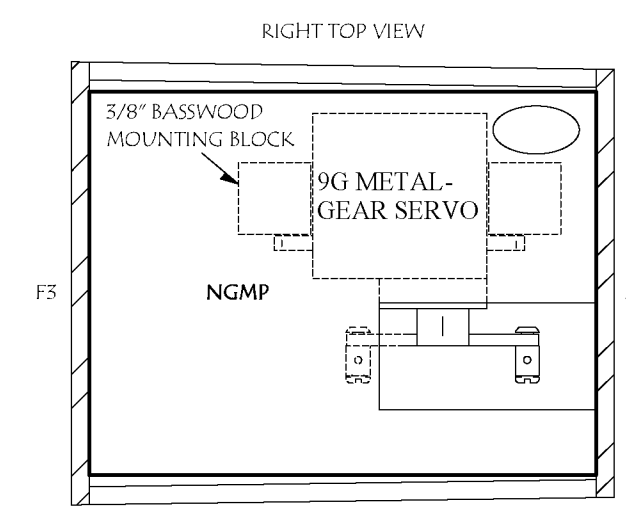
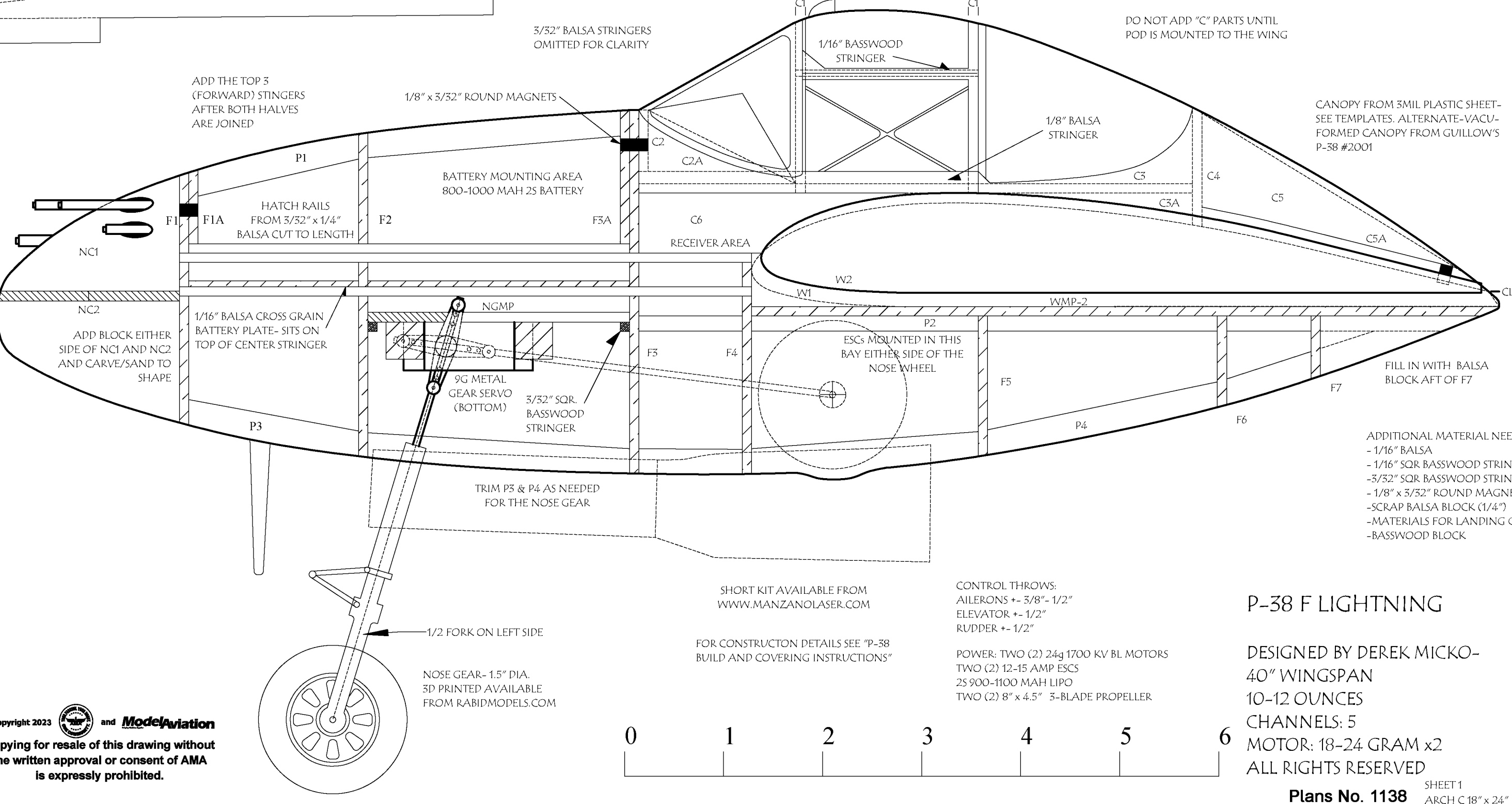
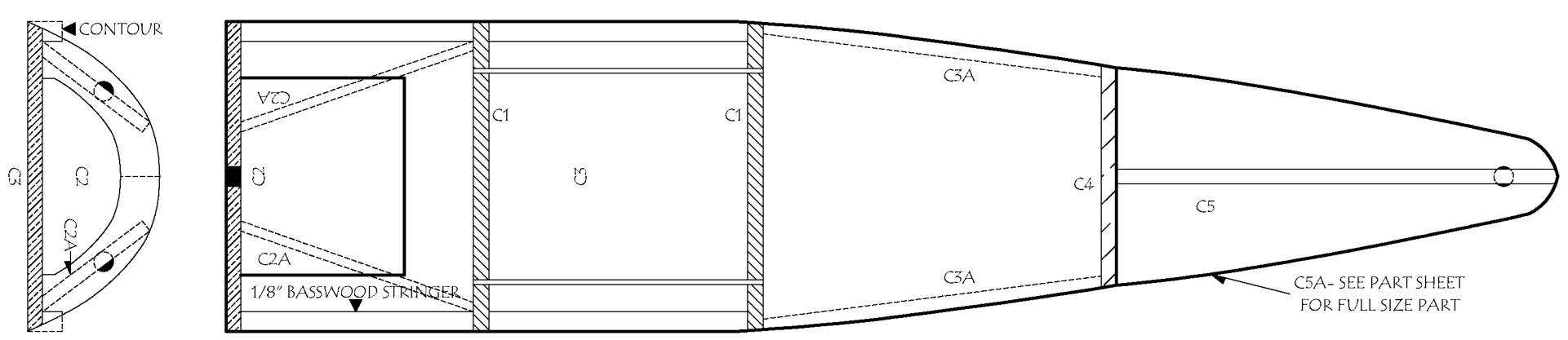

- ADDITIONAL MATERIAL NEEDED
- 1/16" Balsa
 - 1/16" SQR BASSWOOD STRINGER
 - 3/32" SQR BASSWOOD STRINGER
 - 1/8" x 3/32" ROUND MAGNETS
 - SCRAP Balsa BLOCK (1/4")
 - MATERIALS FOR LANDING GEAR
 - BASSWOOD BLOCK

CONTROL THROWS:
 AILERONS +- 3/8" - 1/2"
 ELEVATOR +- 1/2"
 RUDDER +- 1/2"

POWER: TWO (2) 24g 1700 KV BL MOTORS
 TWO (2) 12-15 AMP ESCS
 25 900-1100 MAH LIPO
 TWO (2) 8" x 4.5" 3-BLADE PROPELLER

P-38 F LIGHTNING

DESIGNED BY DEREK MICKO-
 40" WINGSPAN
 10-12 OUNCES
 CHANNELS: 5
 MOTOR: 18-24 GRAM x2
 ALL RIGHTS RESERVED

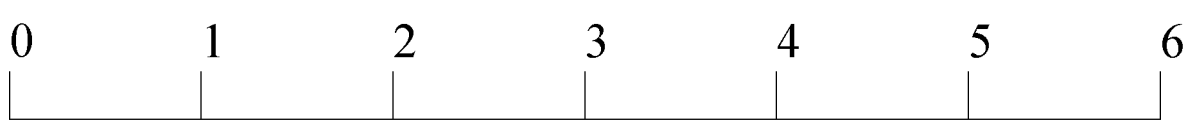

Copyright 2023 and **ModelAviation**
 Copying for resale of this drawing without the written approval or consent of AMA is expressly prohibited.

SHORT KIT AVAILABLE FROM WWW.MANZANOLASER.COM

FOR CONSTRUCTION DETAILS SEE "P-38 BUILD AND COVERING INSTRUCTIONS"

