

F

1

2

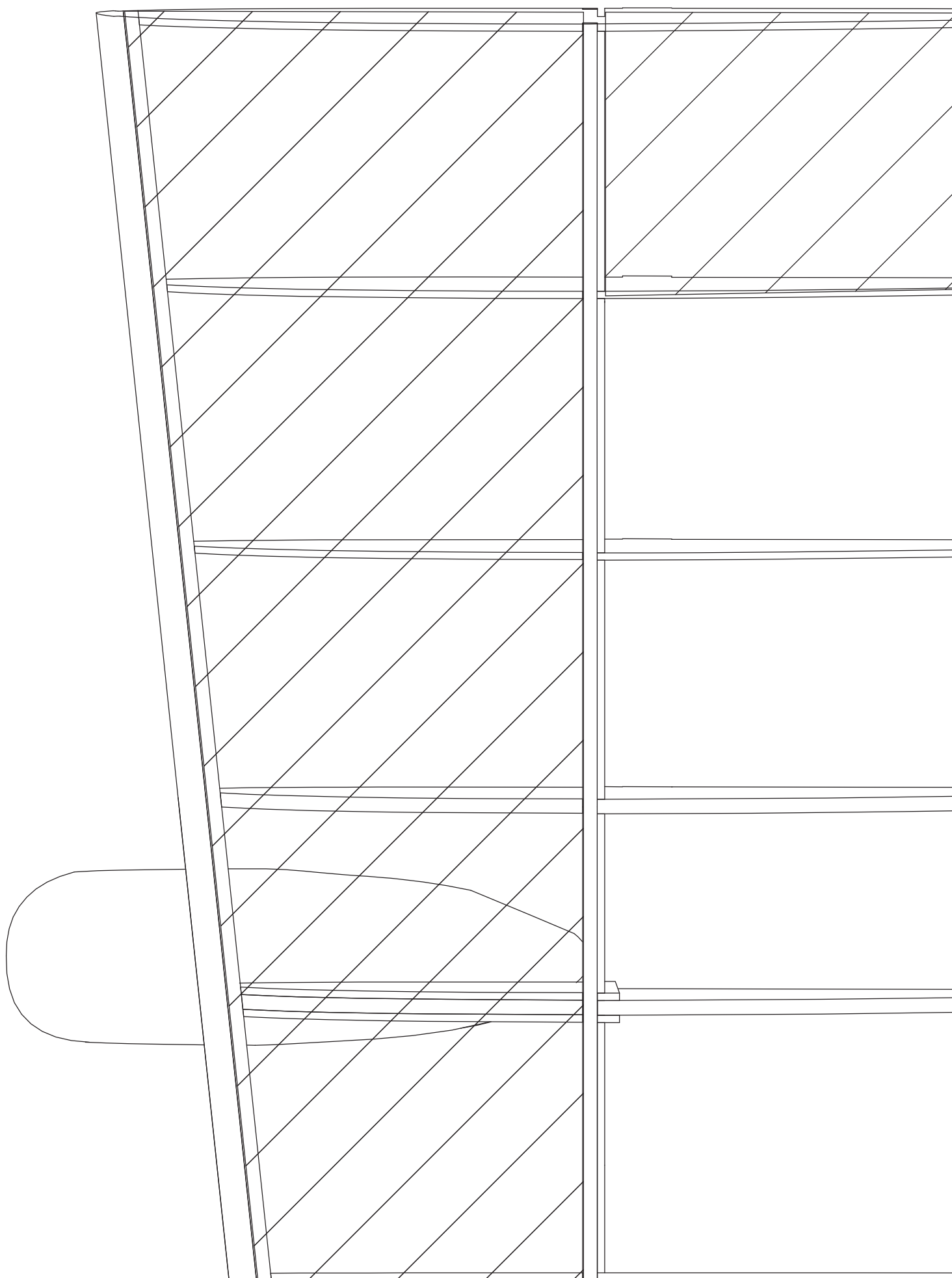

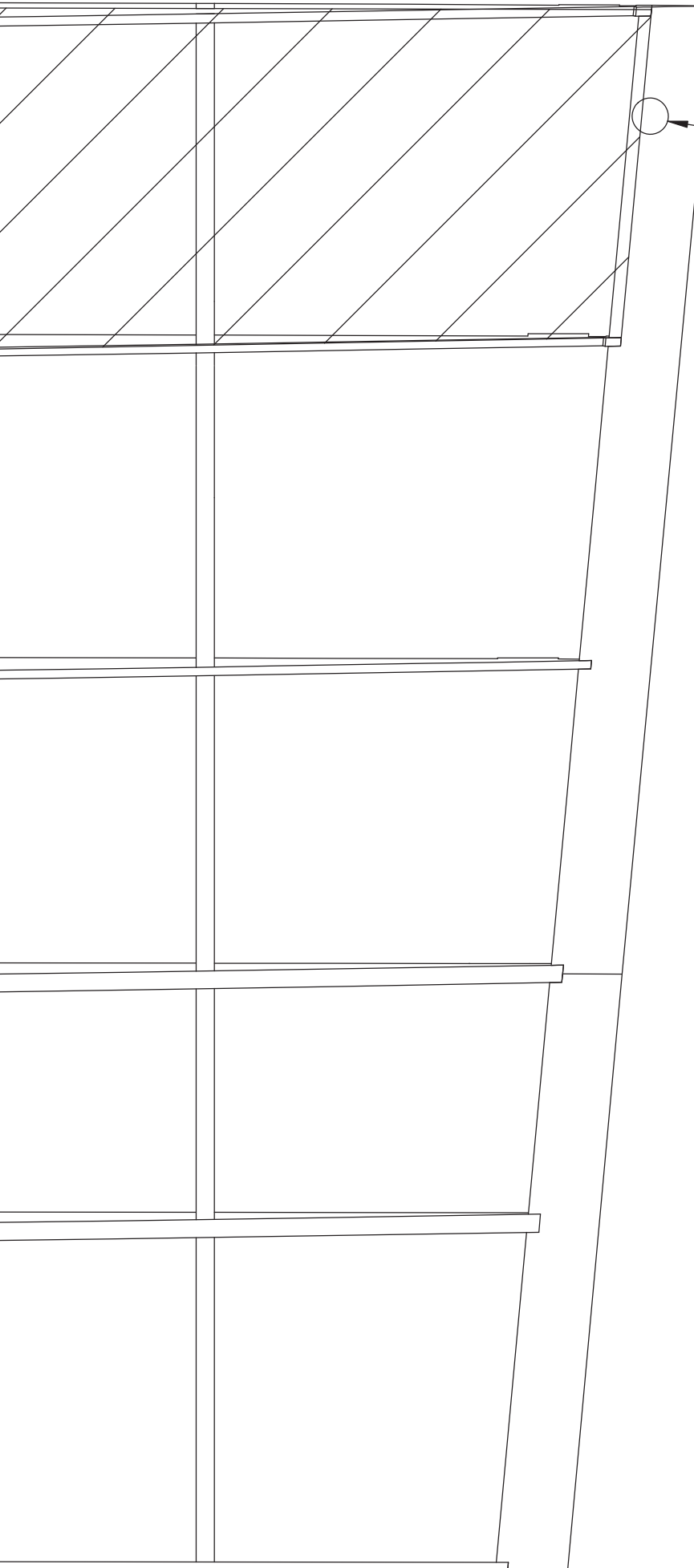



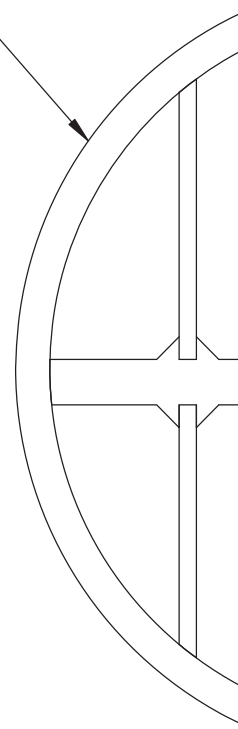

1/4" Through Hole for
12-24 Wing Bolt

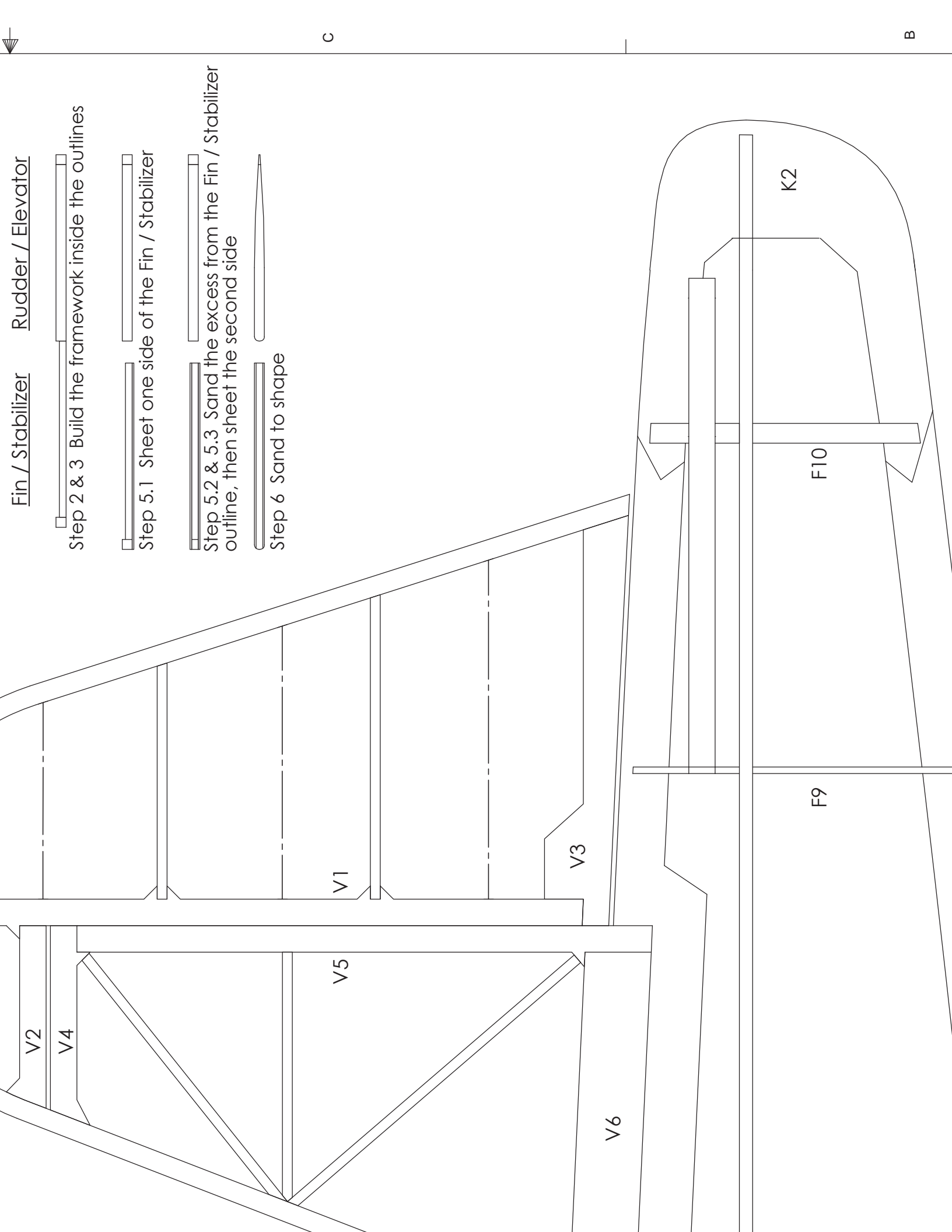
Form Tail Group Outlines by
laminating three strips of 1/16" x 3/16"
balsa together around a form





Fin / Stabilizer Rudder / Elevator

- 
 Step 2 & 3 Build the framework inside the outlines
- 
 Step 5.1 Sheet one side of the Fin / Stabilizer
- 
 Step 5.2 & 5.3 Sand the excess from the Fin / Stabilizer outline, then sheet the second side
- 
 Step 6 Sand to shape

V2

V4

V1

V5

V3

V6

F9

F10

K2

C

B

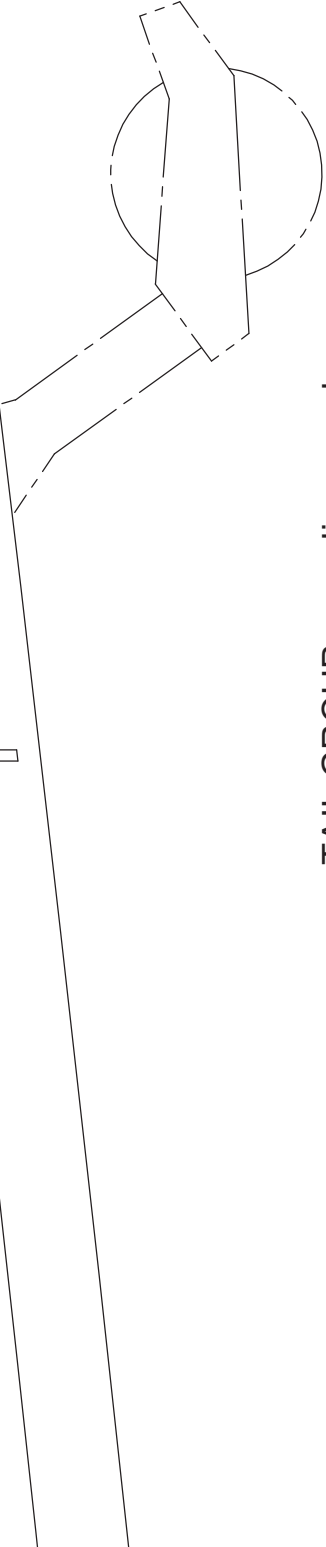

TAIL GROUP--see diagram above

Sheeting the fin and horizontal stabilizer and covering the rudder and elevators as frameworks provides durability with a scale appearance.

1. Begin tail group assembly by laminating each of their outlines from three strips of 1/16" x 3/16" balsa around a form.
2. Install the framework parts in numerical order.
3. Glue in the balsa bracing:
 1. Use 3/32" x 1/8" for the Fin and Horizontal Stabilizer.
 2. Use 3/32" x 3/16" for the Rudder and Elevators.
4. Separate the Rudder from the Fin and the Elevators from the Horizontal Stabilizer.
5. Sheet the Fin and the Horizontal Stabilizer on both sides with 1/32" balsa.
 1. Sheet the bottom sides first.
 2. Sand away excess material from the top of the outlines with 60 grit.
 3. Sheet the top sides.
 4. Once sheeting is in place, thickness of fin and stabilizer will match rudder and elevators.
6. Sand to shape

Note: The positions of critical bracing is shown on the Rudder and Elevators. Additional bracing positions of the full scale M.20 are shown as dashed lines and are optional.

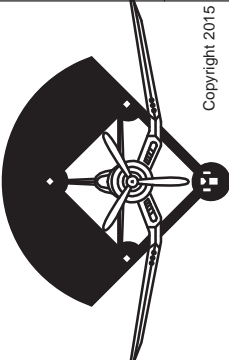
INFIELD ENGINEERING tm by Paul Kohlmann		45" Miles M.20 Pocket Fighter	
	Title	Size	Rev
Copyright 2015 Laser cut kit with plastics available from Manzano Laser Works www.manzanolaser.com	E	Dwg. No. Miles M.20 plan	C
Scale: 1:1	Weight: 35-40oz	Sheet 1 of 2	

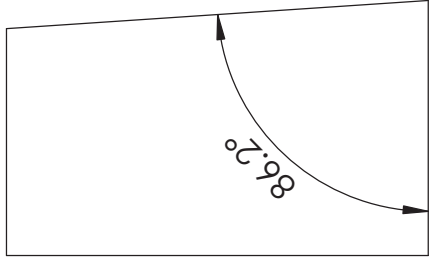

DIHEDRAL

The dihedral is set by installing center wing rib W1 at the angle provided by the Dihedral Gauge.

Completed wing assembly should measure 1.5"/37mm from board to bottom of W11 when wing is level and supported by the tabs on W1.

S).
e of rib W5
ard, W2 thru
nown to create

e A1 to RS!

force Dihedral

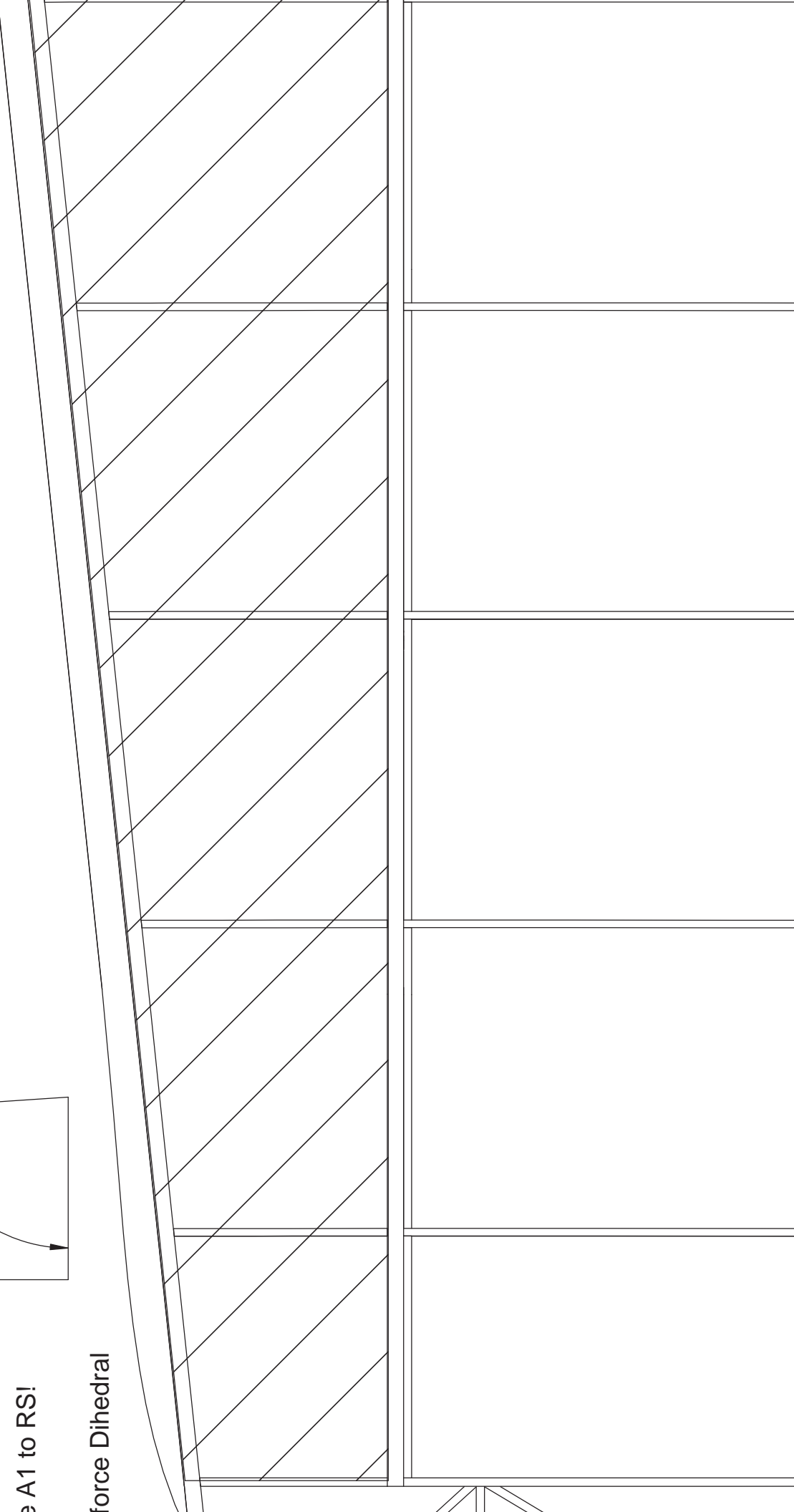

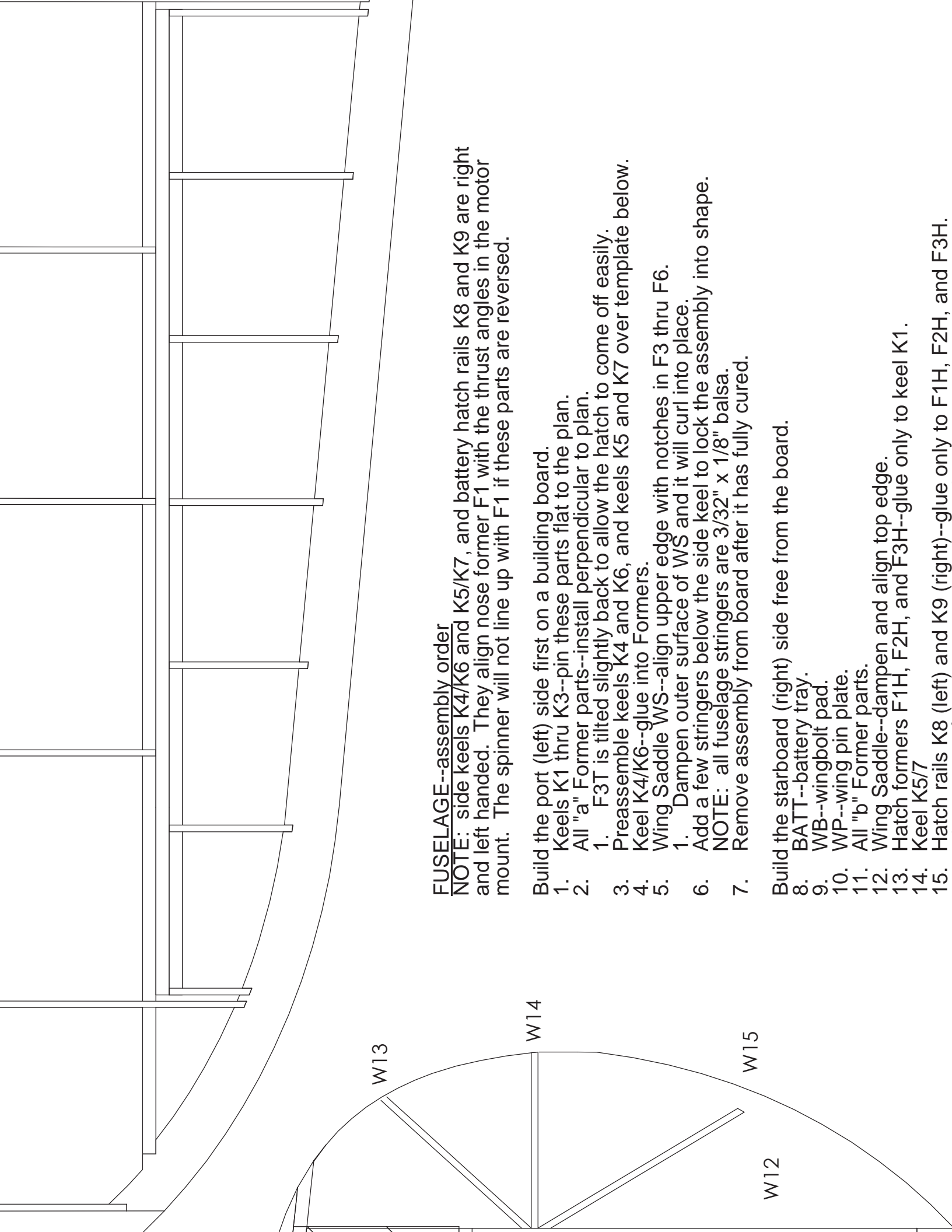

FUSELAGE--assembly order

NOTE: side keels K4/K6 and K5/K7, and battery hatch rails K8 and K9 are right and left handed. They align nose former F1 with the thrust angles in the motor mount. The spinner will not line up with F1 if these parts are reversed.

Build the port (left) side first on a building board.

1. Keels K1 thru K3--pin these parts flat to the plan.
2. All "a" Former parts--install perpendicular to plan.
 1. F3T is tilted slightly back to allow the hatch to come off easily.
3. Preassemble keels K4 and K6, and keels K5 and K7 over template below.
4. Keel K4/K6--glue into Formers.
5. Wing Saddle WS--align upper edge with notches in F3 thru F6.
 1. Dampen outer surface of WS and it will curl into place.
6. Add a few stringers below the side keel to lock the assembly into shape.
NOTE: all fuselage stringers are 3/32" x 1/8" balsa.
7. Remove assembly from board after it has fully cured.

Build the starboard (right) side free from the board.

8. BATT--battery tray.
9. WB--wingbolt pad.
10. WP--wing pin plate.
11. All "b" Former parts.
12. Wing Saddle--dampen and align top edge.
13. Hatch formers F1H, F2H, and F3H--glue only to keel K1.
14. Keel K5/7
15. Hatch rails K8 (left) and K9 (right)--glue only to F1H, F2H, and F3H.

16. F1--ply nose former, glue only to K1, K3, K4, and K5.
17. Stringers--alternate from side to side to avoid warps.
NOTE: route stringers to create a slot for the Horizontal Stabilizer by using the tabs on F9 and F10.
18. Knock out K1 between F4 and F5 to create cockpit opening.
19. Knock out K3 between F3 and WB to create wing pocket.

SIDE KEEL TEMPLATES: join these two halves before inserting into formers

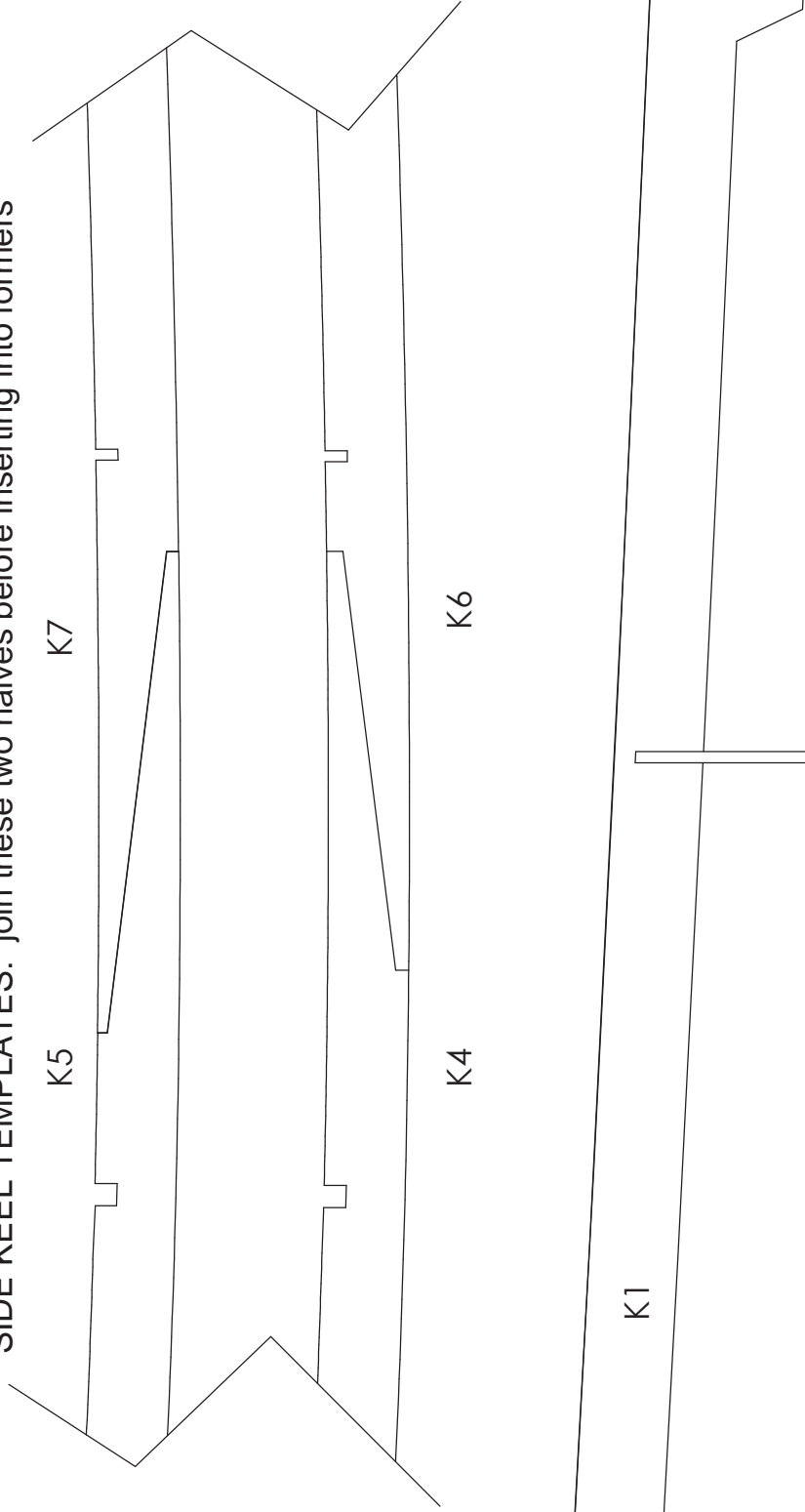

K6/7

SERVO

F7

F8

F6

K1

K4

K6

K5

K7

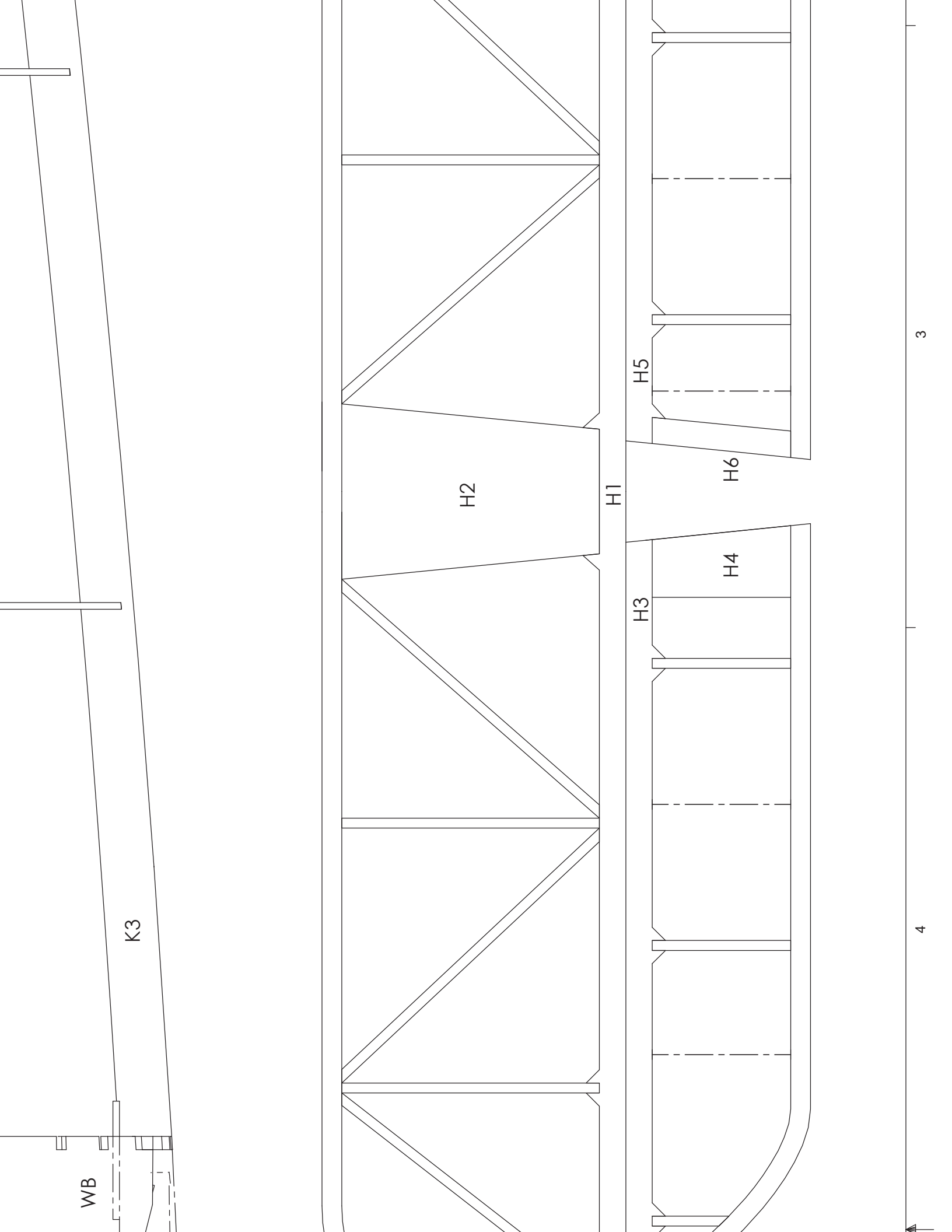

WB

K3

H2

H1

H3

H4

H5

H6

4

3

MILES M.20 VARIANTS

Only two Miles M.20's were produced. The first went from the drawing board to flight testing in a blistering 67 days. It was built mostly of wood, was powered by the integrated Rolls Royce Merlin "Power Egg", and used many parts, including the wing, from existing Miles aircraft.

Initially identified as U9 and later as AX834, this craft was submitted to the RAF in September of 1940 as a simple emergency fighter that might bolster the dwindling supply of Spitfires and Hurricanes as the Battle of Britain raged. The model detailed here is of this RAF variant.

Some time later, the Fleet Air Arm (FAA) expressed interest in a light, disposable fighter that could be catapulted from ships and ditched after the sortie. A second M.20 identified as U-0228 was presented to the FAA for testing. The primary differences between the two prototypes were the spinners and the landing gear spats. Outlines for the FAA version are provided for reference.

WING--assembly order

1. Pin down lower main spar and rear spar (RS)
2. Epoxy the ply doublers W5B to to each side
3. Ribs W2 thru W11.
Note: W6 thru W11 are perpendicular to board
W5 are angled by RS and LE.
4. Trailing edge (TE)--crack and glue where she
Dihedral Break
5. Rib W1--set angle with Dihedral Gauge.
6. LE, upper mainspar, and shear webs.
7. Aileron parts in numerical order--do not glue
8. Wing Tip--W12 thru W15.
9. Unpin assembly from board.
10. Epoxy Brace 1 between W3 and W6 to rein
Break and Landing Gear Strut
11. Sheet as shown with 1/16" balsa.
12. 1/4" Soft balsa leading edge.
13. Join wings with Brace 2.
14. Install a wing pin from 1/4" dowel
where marked on ribs W1



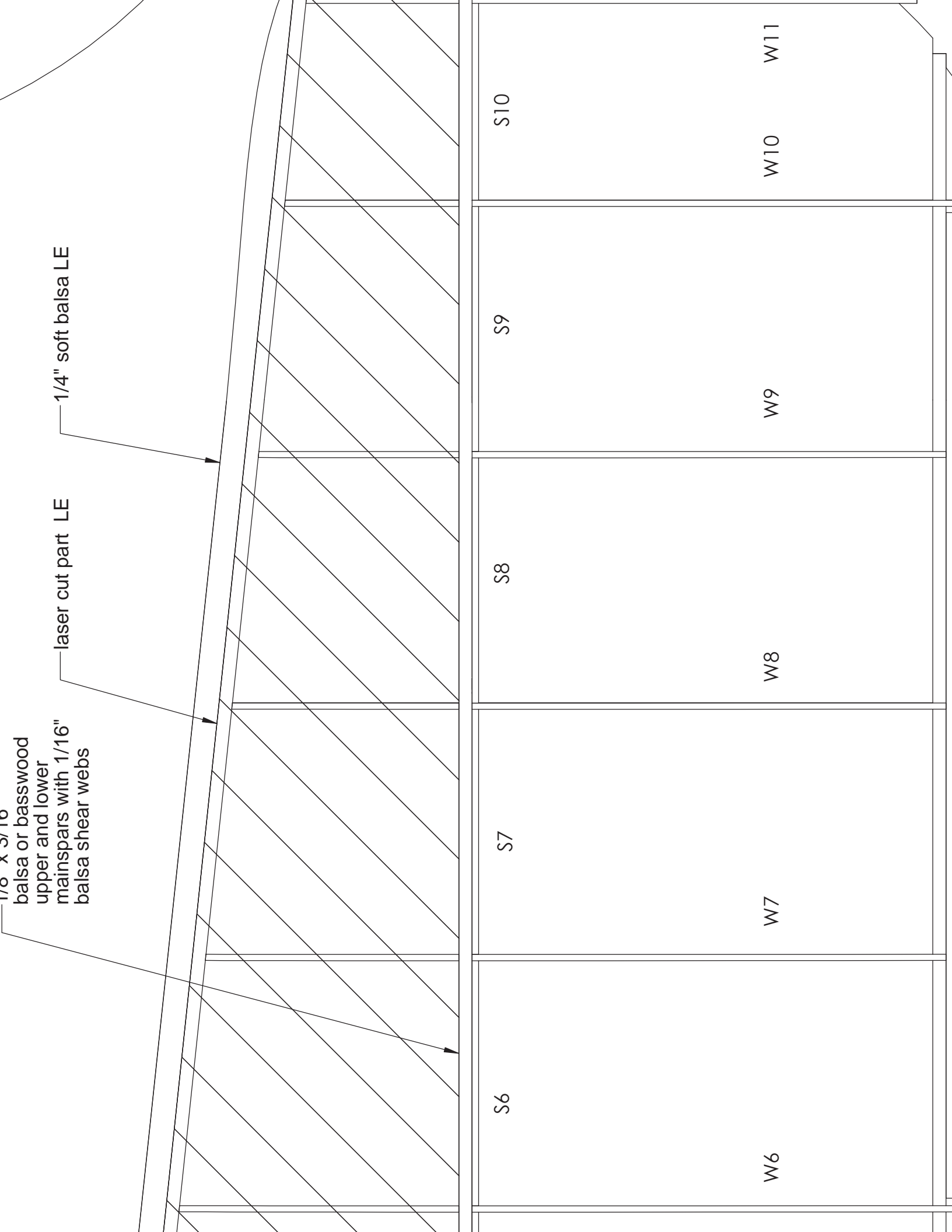

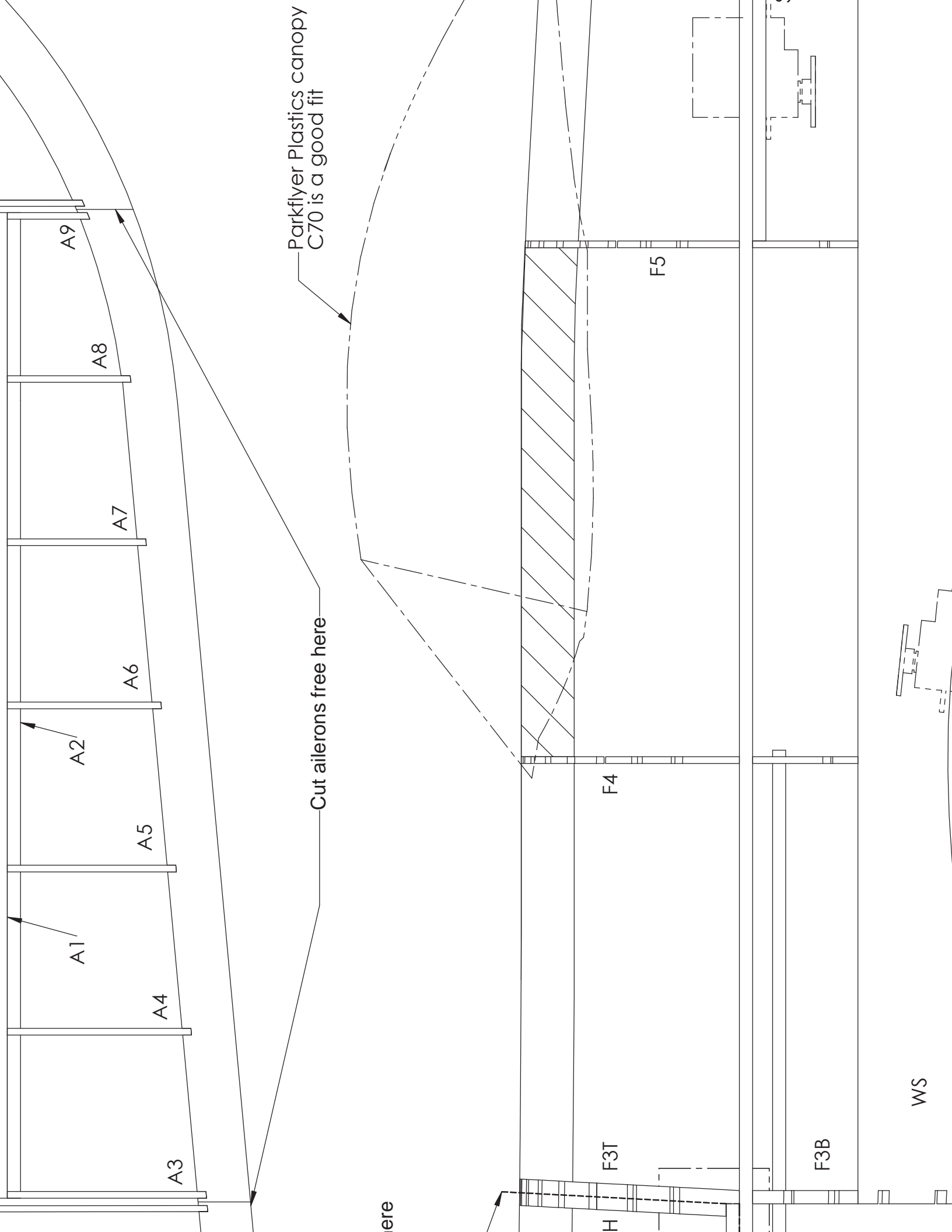

A9

A8

A7

A6

A2

A5

A1

A4

A3

Parkflyer Plastics canopy
C70 is a good fit

Cut ailerons free here

ere

F5

F4

F3T

F3B

WS

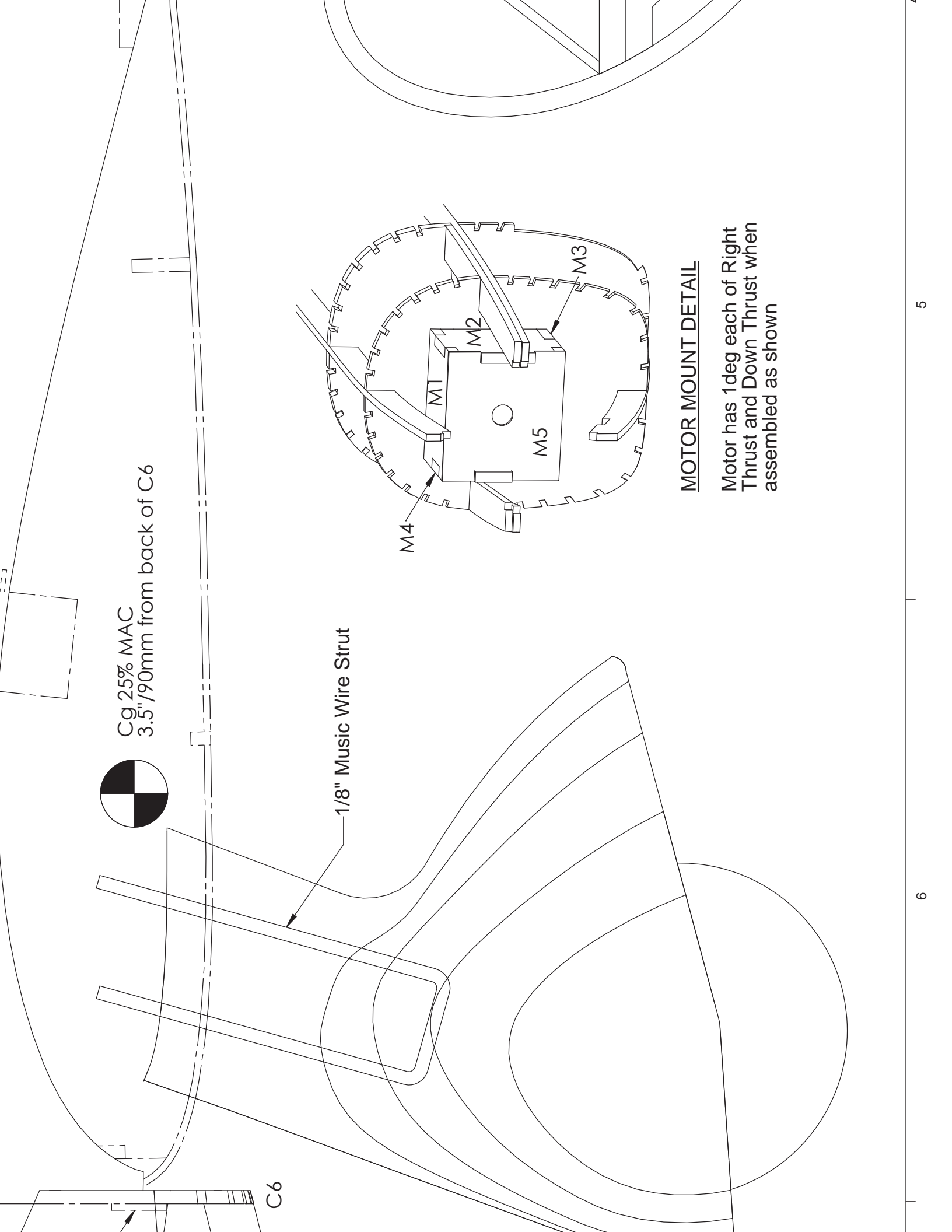

SPECIFICATIONS	
Wingspan	45"
Length	40.25"
Weight	36oz
Wing Area	403 sq in
Power	480 1000kV
Propellor	11 x 7 3-blade
Battery	3S 2200mAh

LANDING GEAR--assembly order

1. Bend 1/8" music wire strut as shown on fuse drawing.
2. Build landing gear from center out, one side at a time.
3. Assemble G1 thru G7 as shown.
4. Epoxy the music wire strut into the groove in G1.
5. Assemble Side 2--G2 thru G7.
6. Sand the assembly smooth.
7. Fit Wheel and check for clearance.
 1. Wheel size is 75mm.
 2. Fit a wire or dowel axle thru holes in G7.
8. Epoxy the music wire strut into the pockets in the rib W5 assembly.

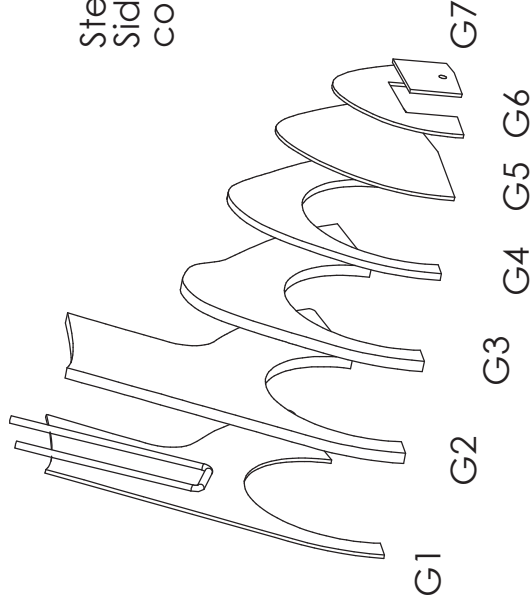

Step 5
Side 1
complete

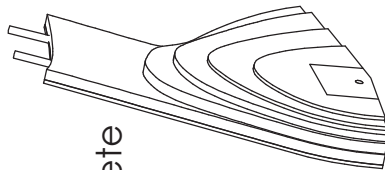

Step 8
Side 1 and 2
complete and
shaped

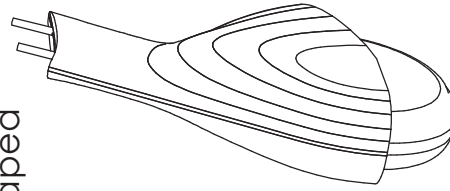

Sheet top and bottom between W1 and W2 back to TE

Sheet top and bottom of wing between W2 and W11

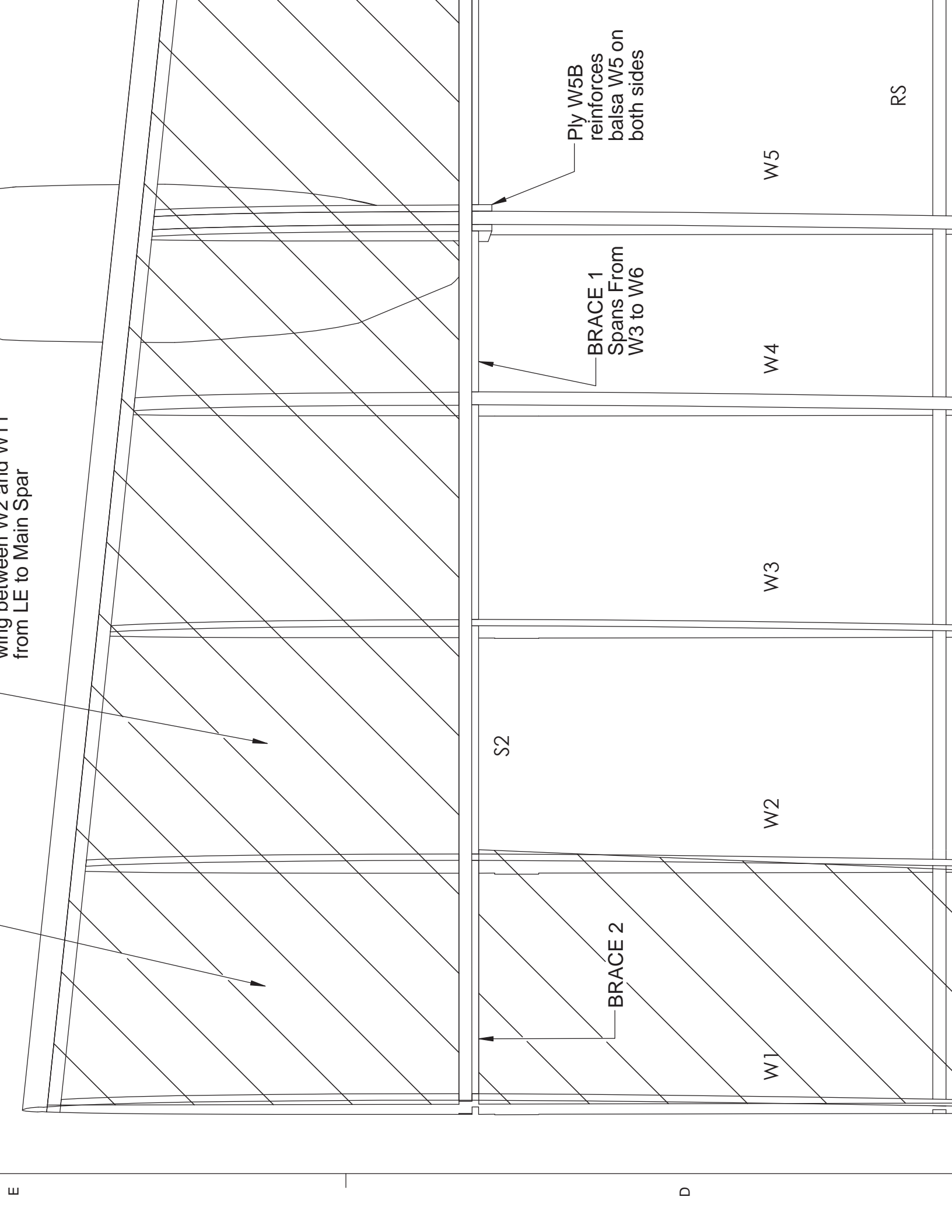

wing between W2 and W1
from LE to Main Spar

Ply W5B
reinforces
balsa W5 on
both sides

BRACE 1
Spans From
W3 to W6

BRACE 2

W5

W4

W3

W2

W1

S2

RS

E

D

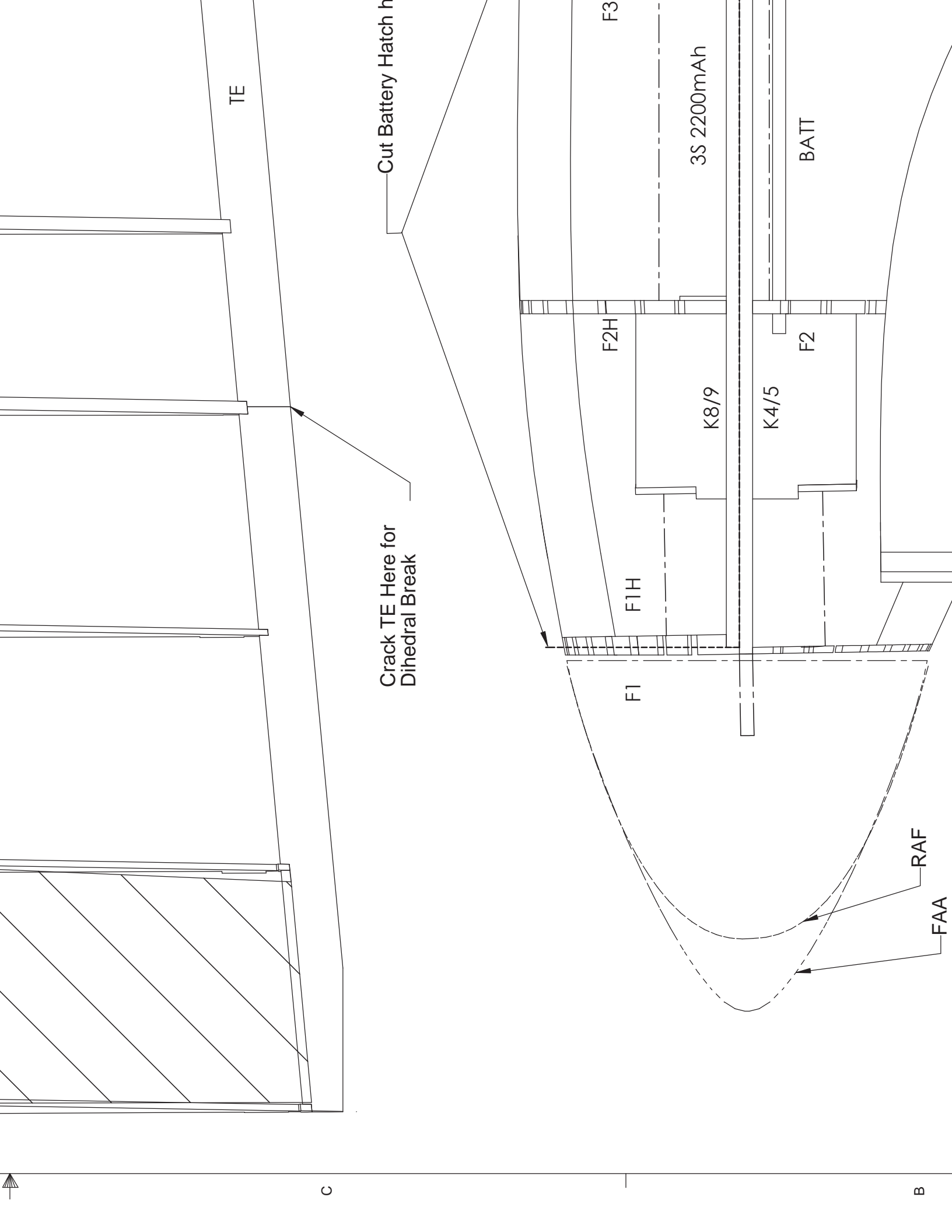

SPINNER OPTIONS

The RAF-style spinner is available as a 3D printable open-source file on Thingiverse.com. Search Miles M.20 Spinner. Please use caution--it is the builder's responsibility to work with a reputable printer and to verify that the resulting part is safe for use.

Alternatively, the Parkzone Bf109 spinner p/n PKZ4907 is a reasonably close fit.

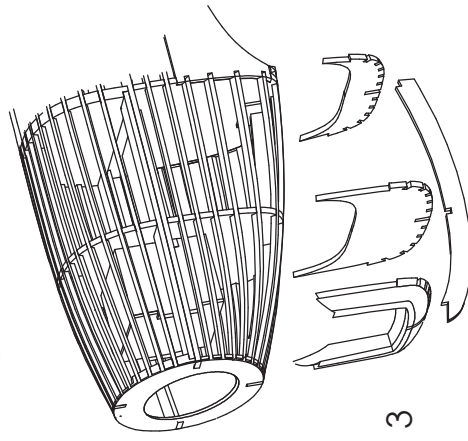

Step 3

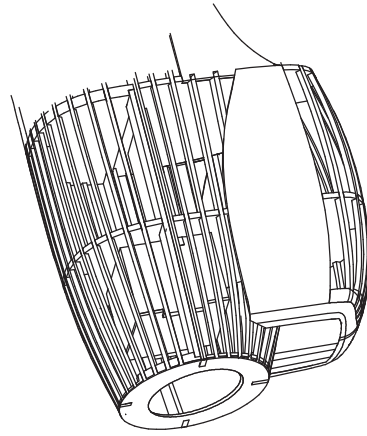

Step 5

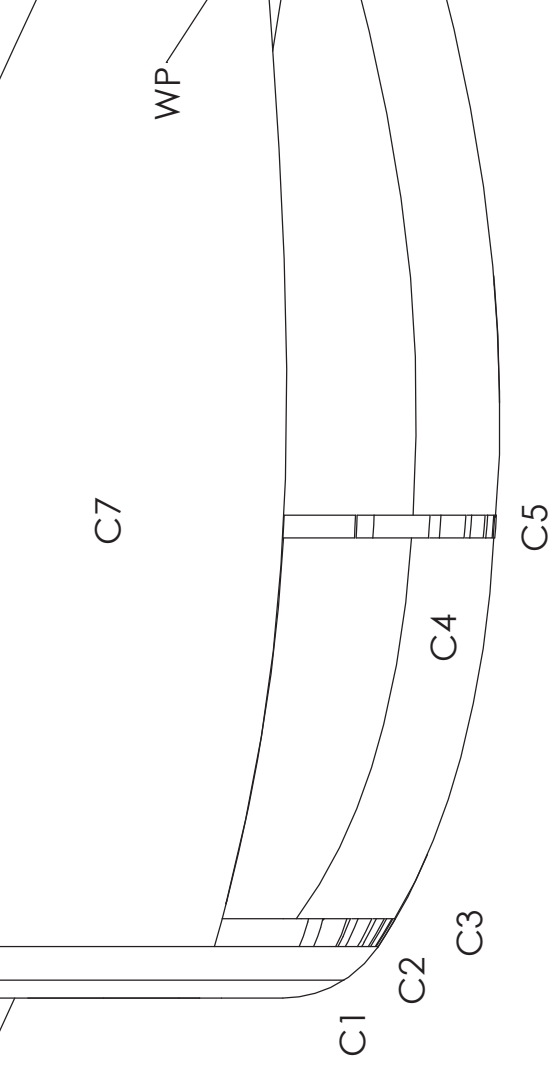

CHIN SCOOP

1. Complete and cover the fuselage.
 1. NOTE: an opening can be left between the lower stringers from F2 to F3 for cooling.
2. Laminate chin formers C1 thru C3 with their scoop openings aligned.
3. Join the Chin Formers with keel C4 and attach this assembly to the fuselage.
4. Attach panels C7 to the sides of the scoop and the fuselage.
 1. NOTE: sand the edges of each C7 to blend neatly to the fuselage
5. Add stringers and cover the scoop.

1

2

ch part

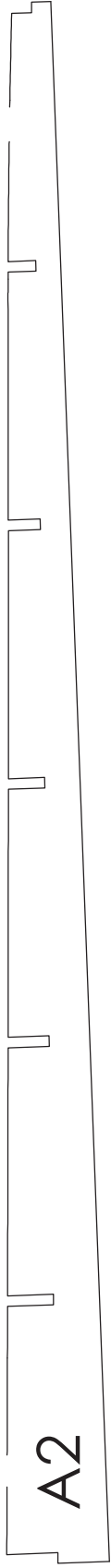
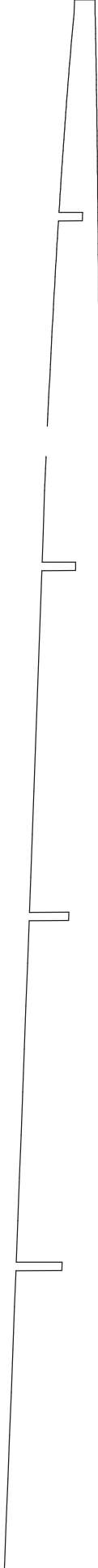

A2

F



TE

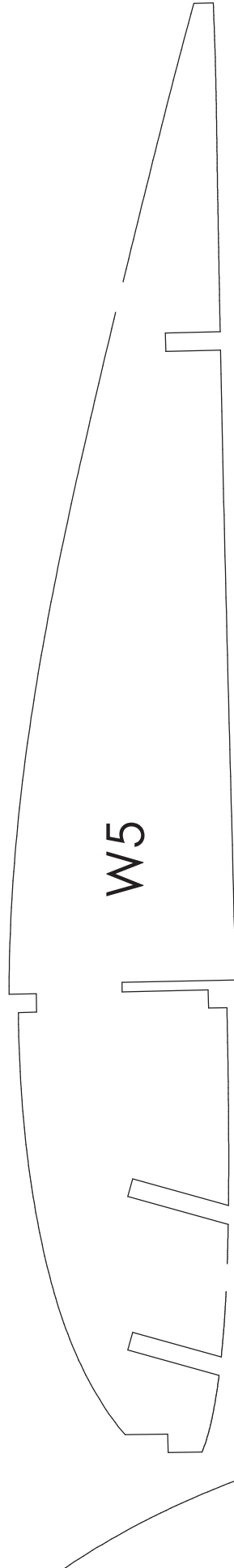
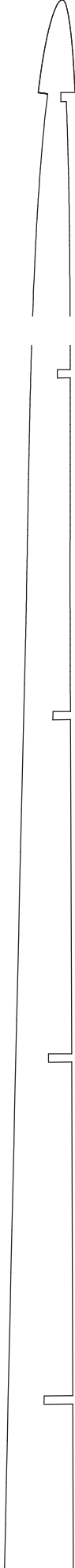

W5

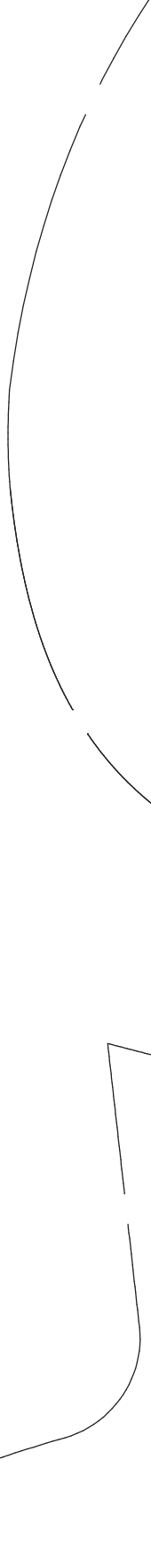

E



W12

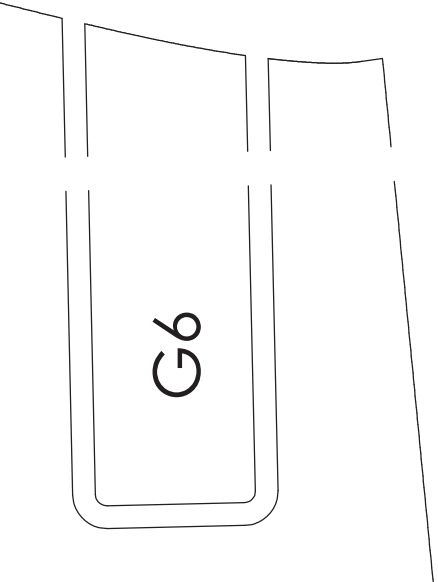

G6

one of each part

D

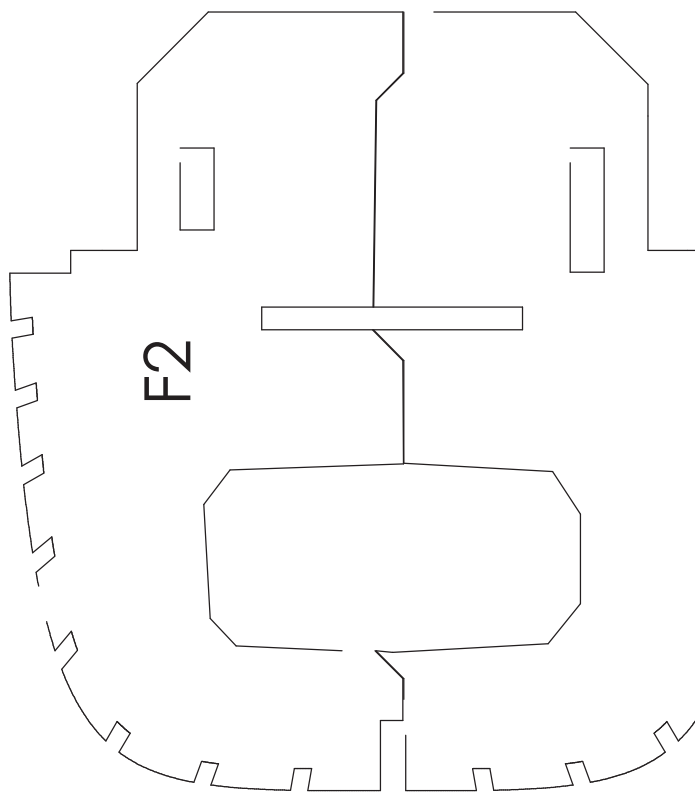

F2

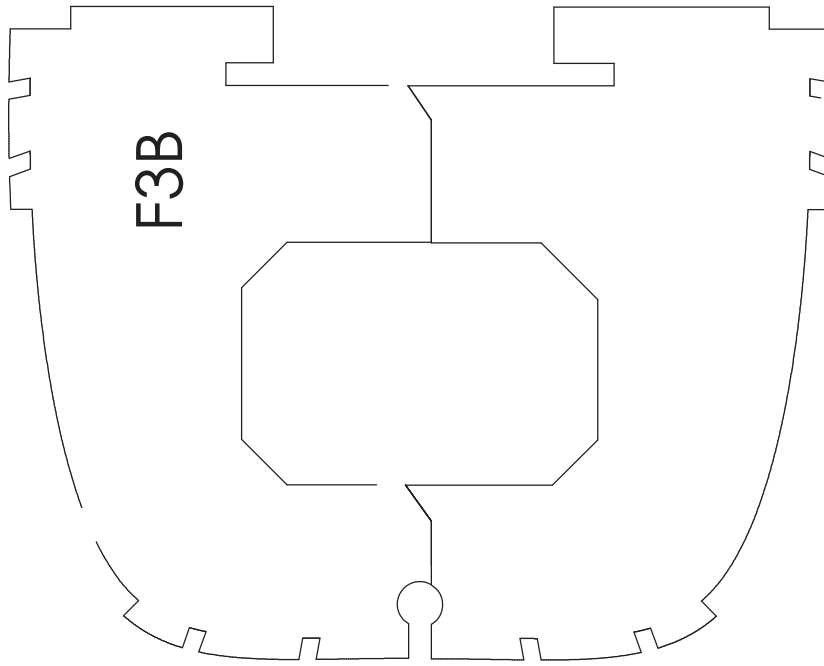

F3B

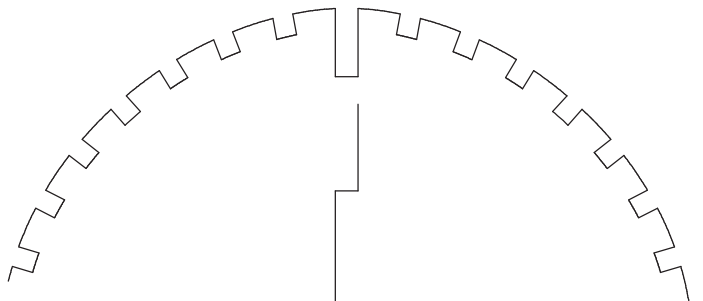

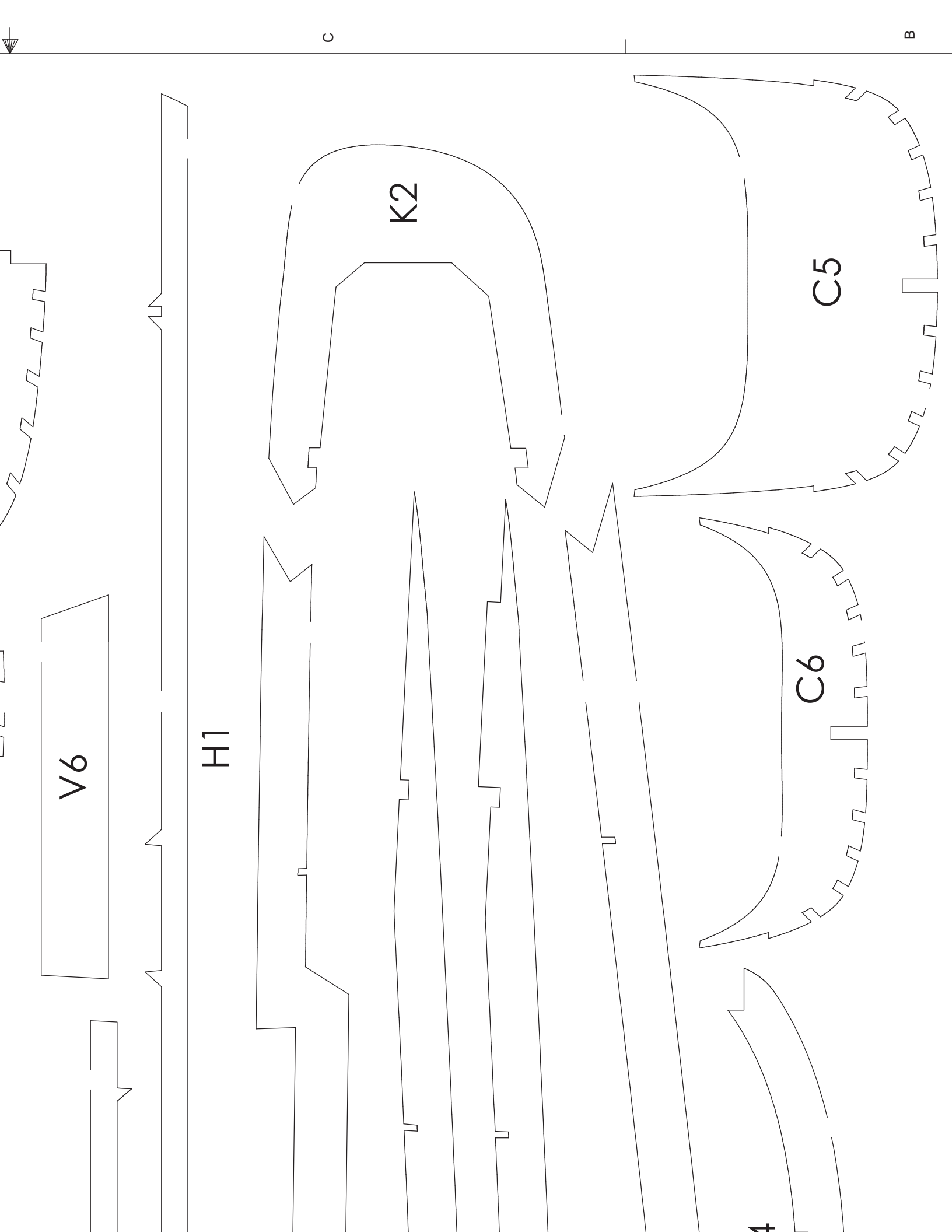

V6

H1

K2

C6

C5

4

c

B

NOTES for Handcutting

This kit was designed from the beginning with laser cutting in mind. But for the more committed, it certainly can be hand cut. If so inclined, disregard the gaps in the part outlines-- they are for the laser cutter so that the parts stay nested in their sheets.

1. Wood grain runs horizontally
2. Fuselage Formers--"a" halves on top, "b" halves on bottom

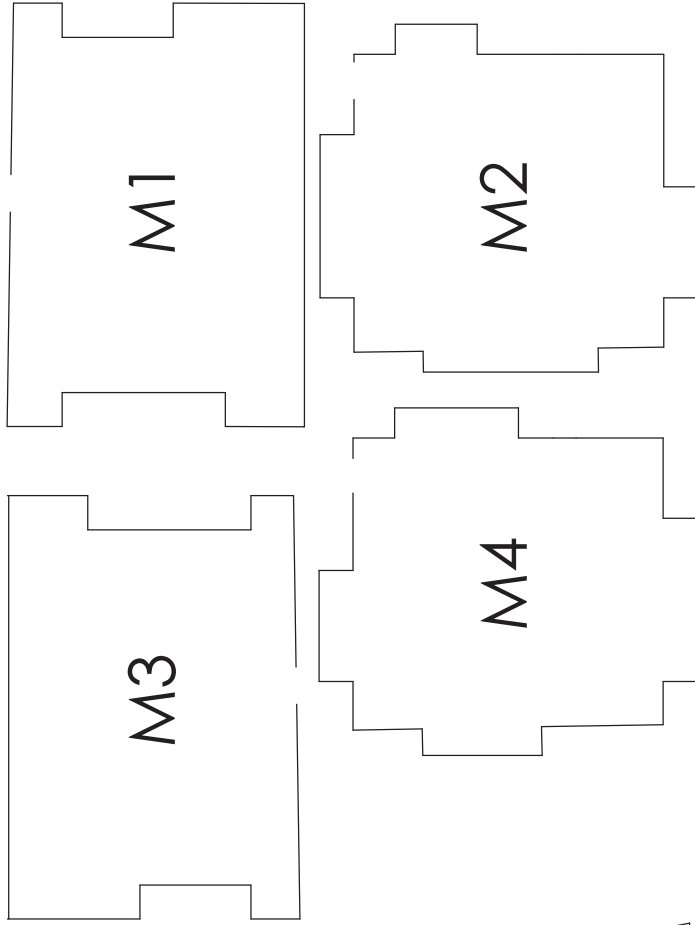

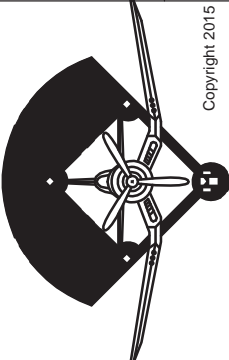
INFIELD ENGINEERING tm by Paul Kohlmann		
		
Title 45" Miles M.20 Pocket Fighter		
Size E	Dwg. No. Miles M.20 plan	Rev C
Scale: 1:1		Weight: 35-40oz
Copyright 2015 Laser cut kit with plastics available from Manzano Laser Works www.manzanolaser.com		Sheet 2 of 2

4

3

1/8" Balsa--make 2 of each

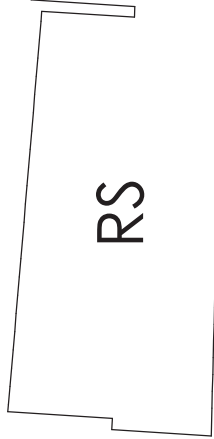

RS

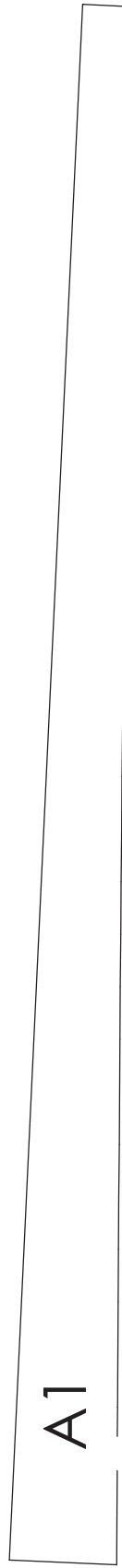

A1

LE

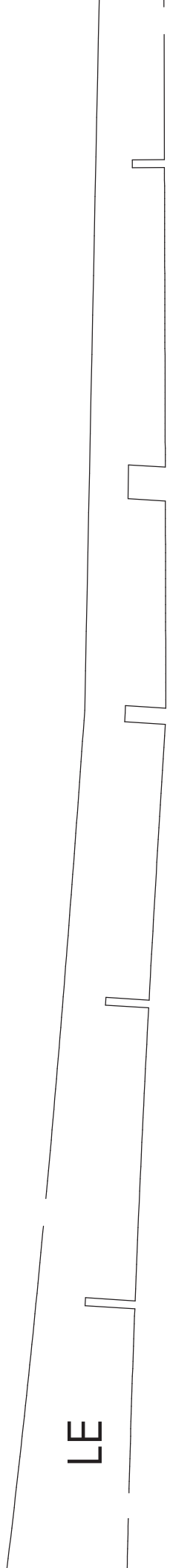

W4

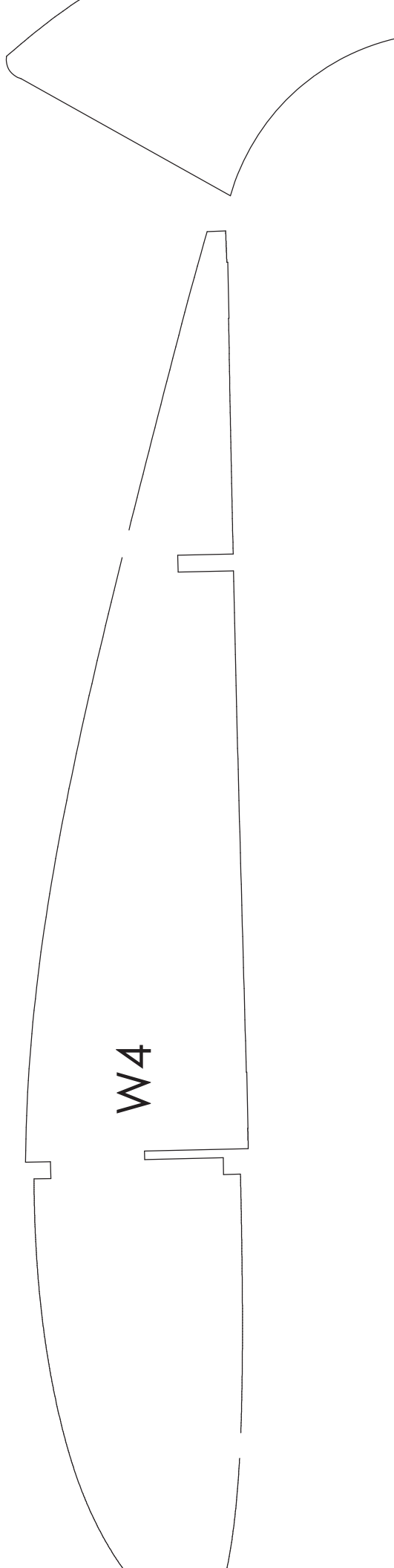

1/8" Balsa--make

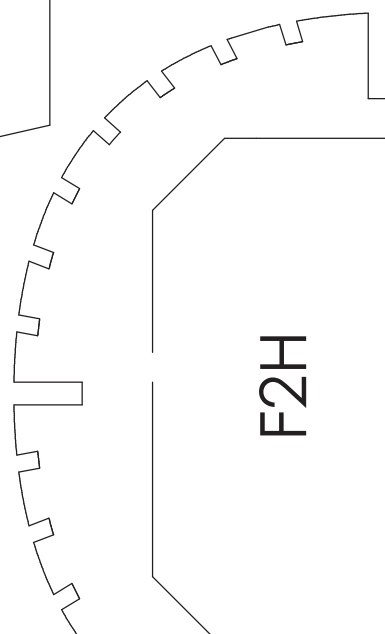
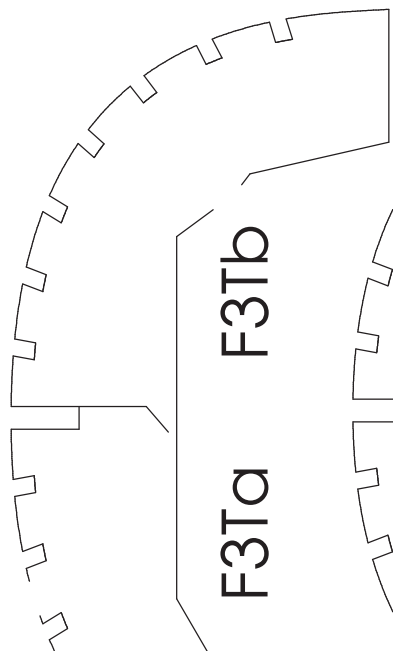
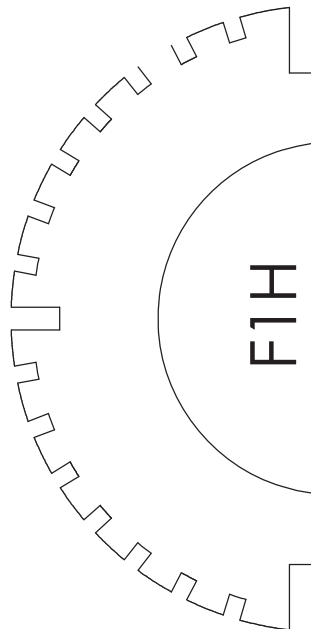
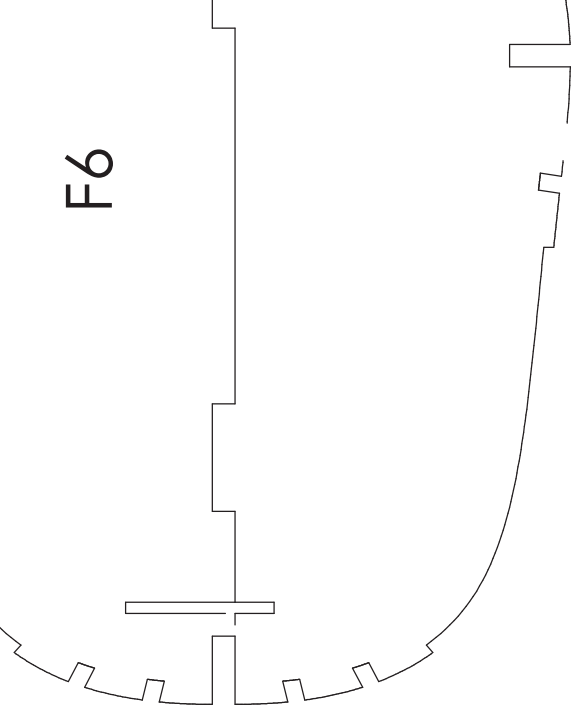
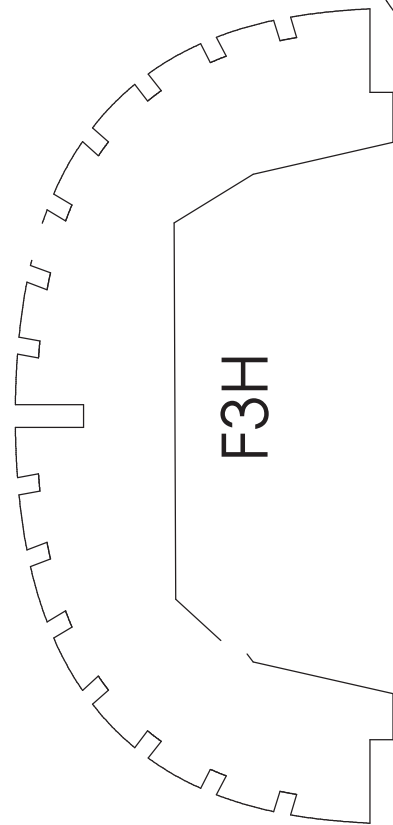
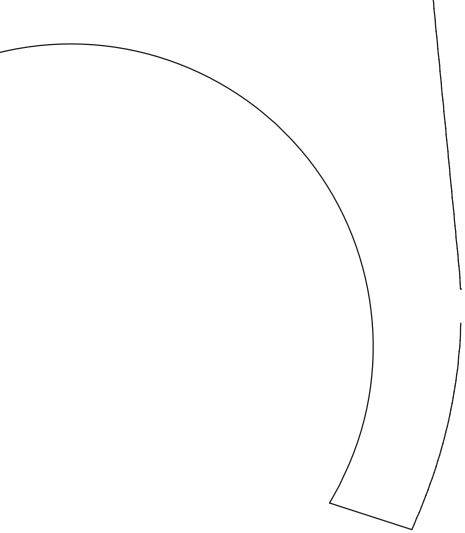

SERVO
TRAY



V5

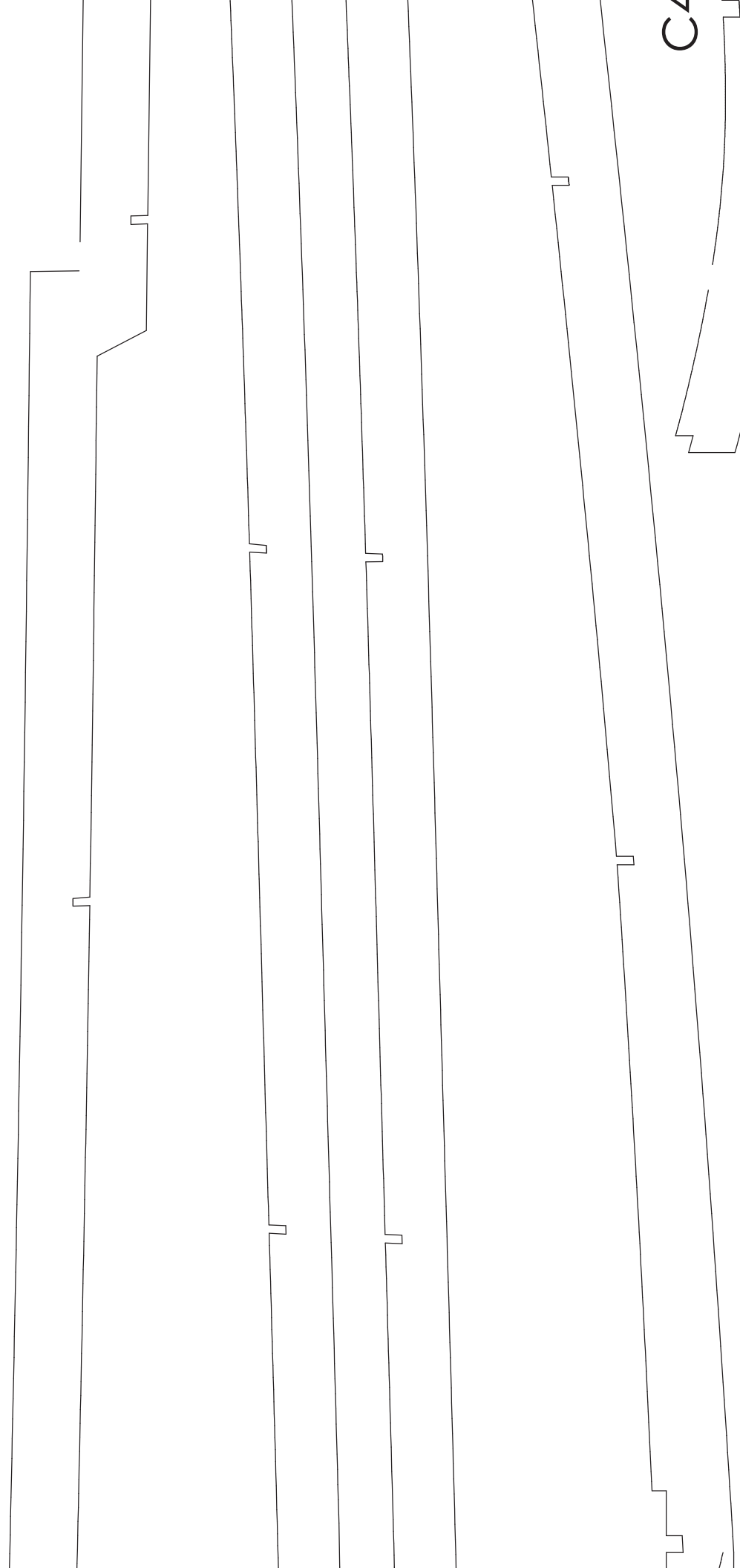

C2

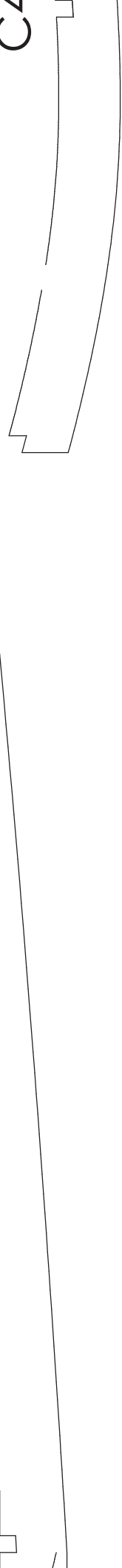

1 1/2" Balsa--make one of each part unless otherwise noted

H3
H5

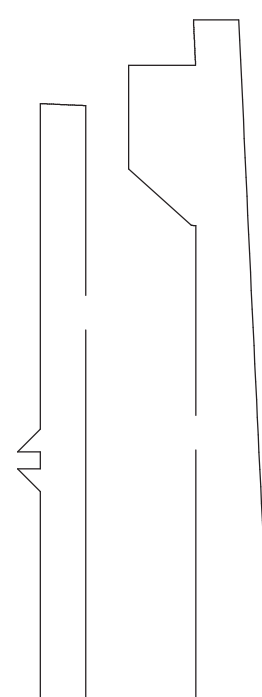
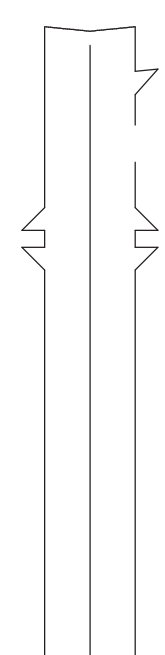

V3

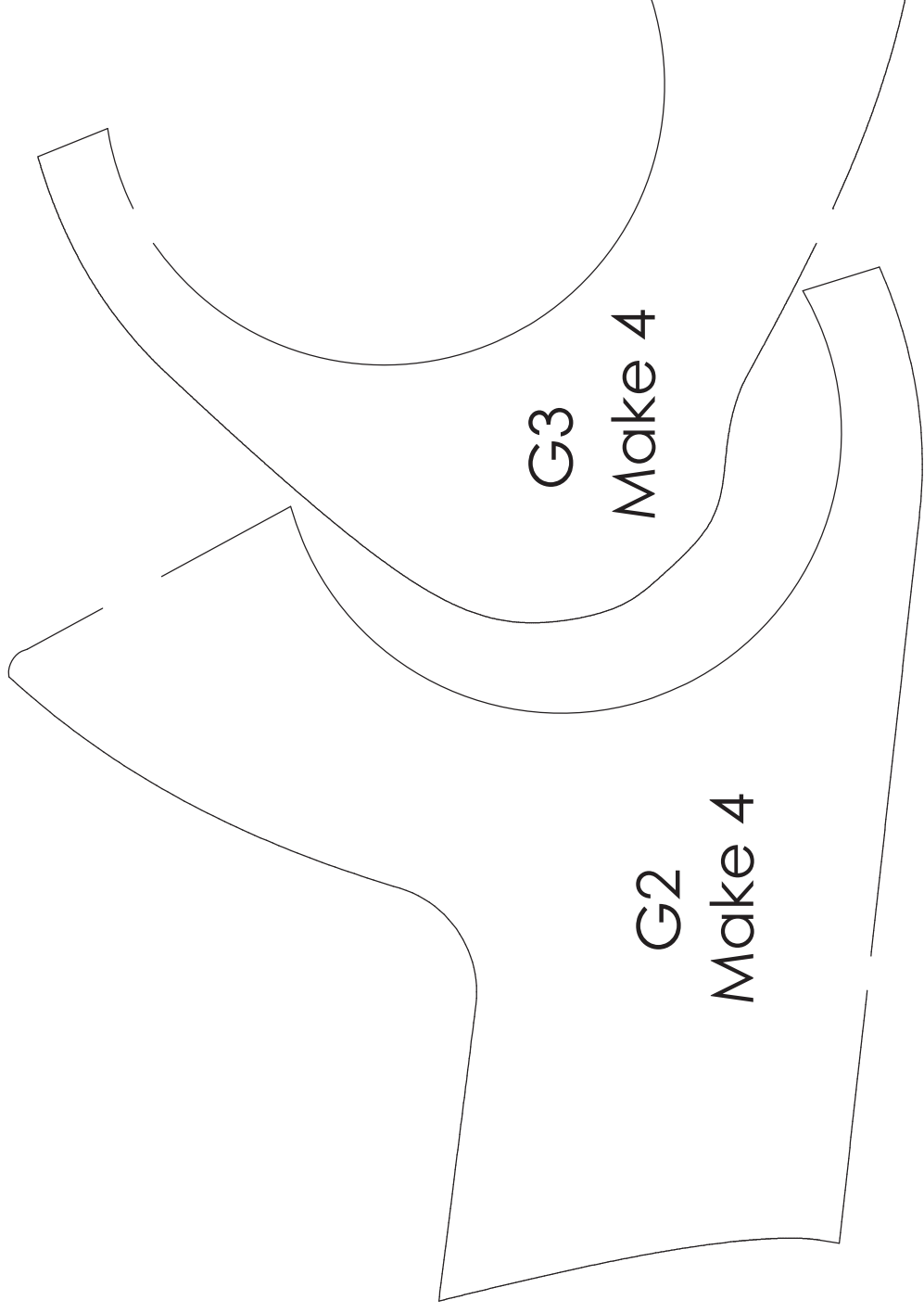
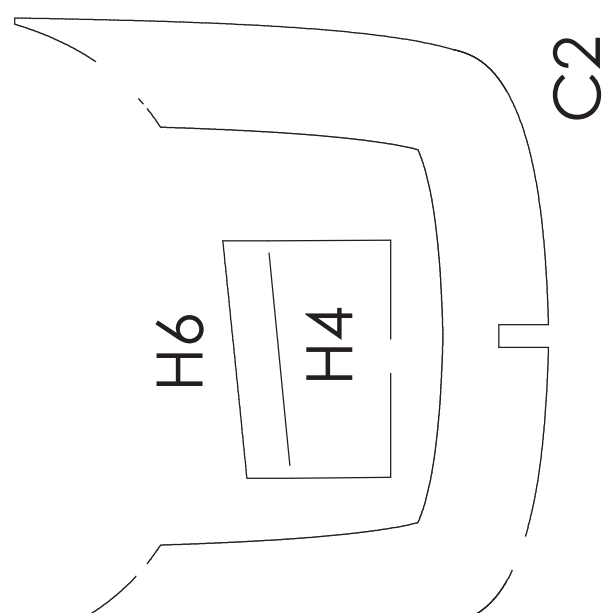

G3

Make 4

G2

Make 4

5

of each part unless otherwise noted

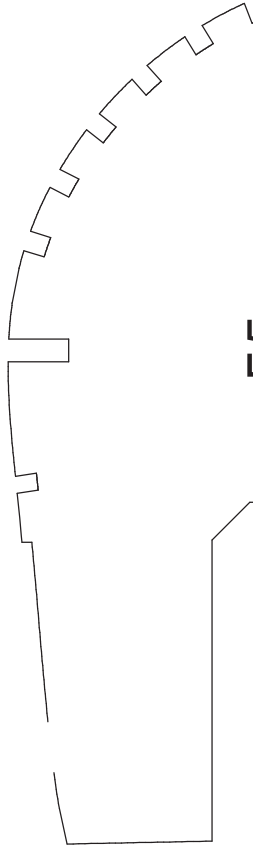
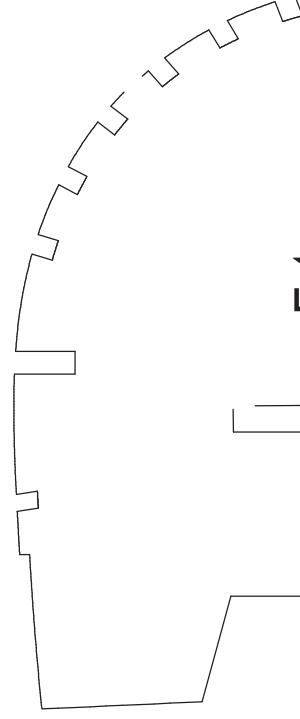
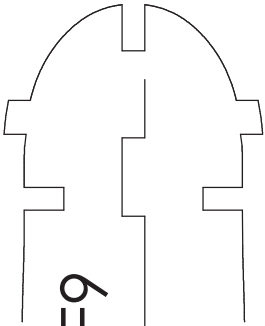
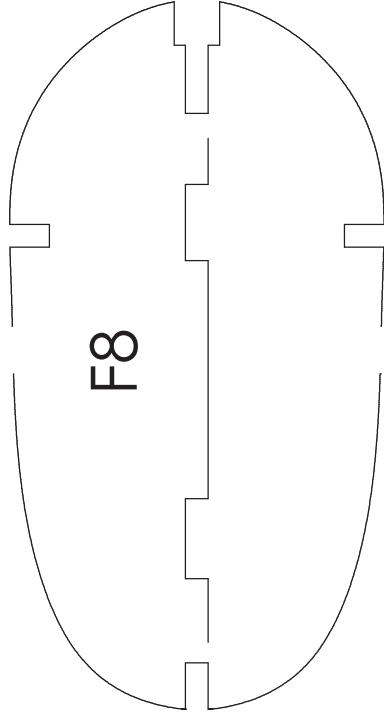
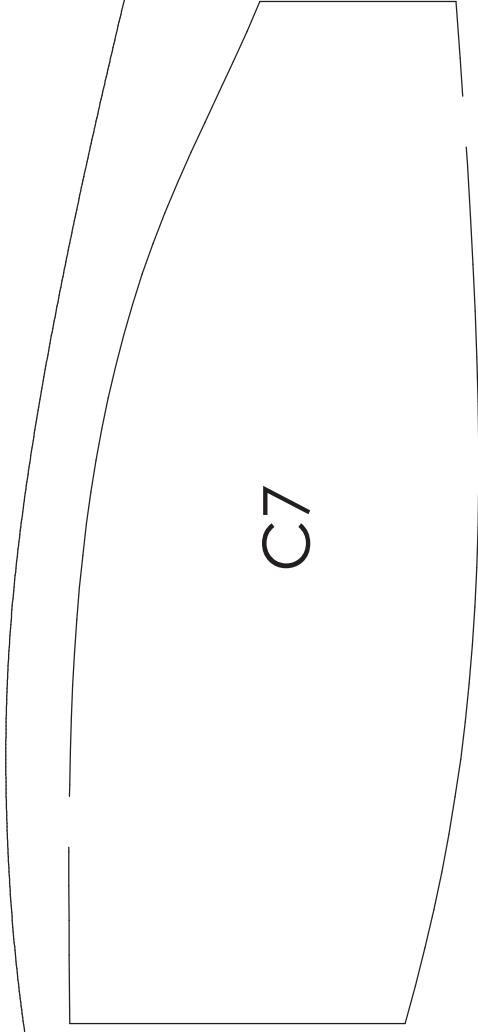
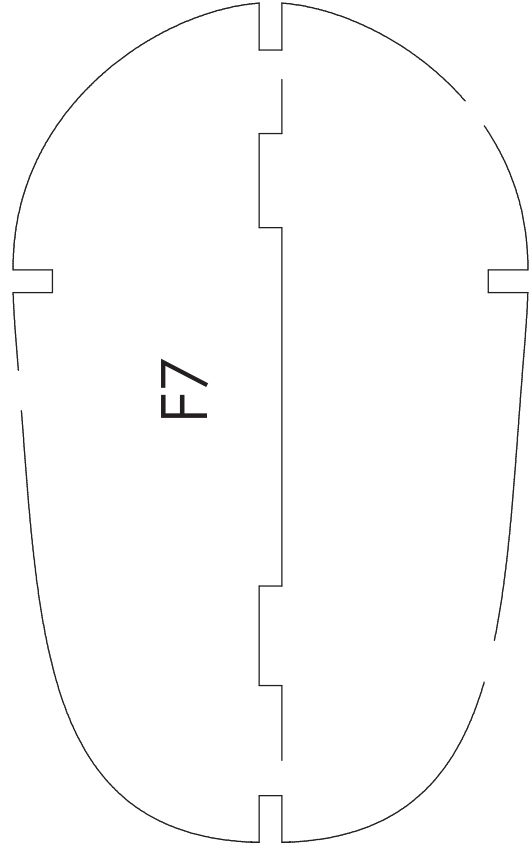
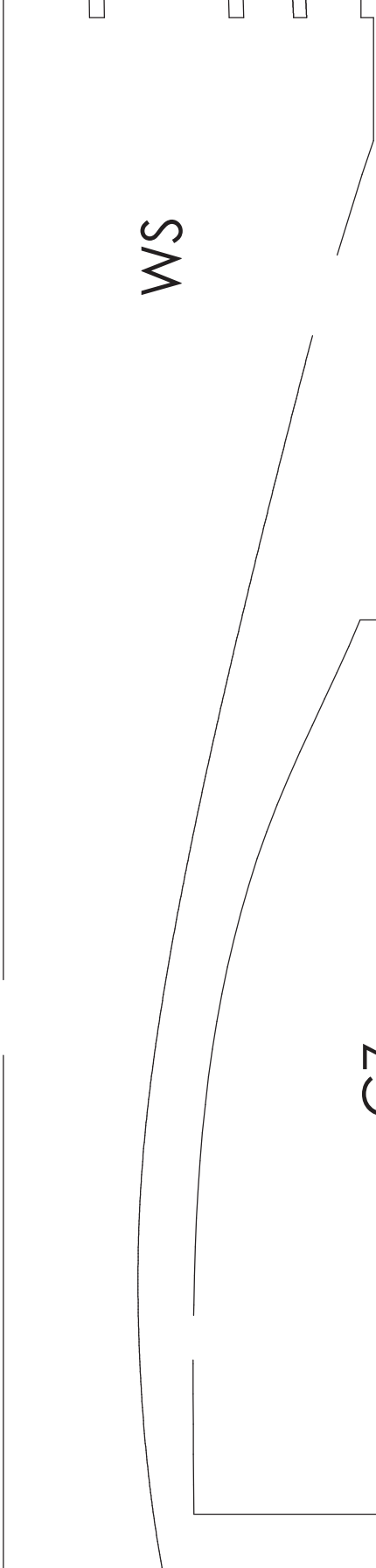

F4

F5

G6

Make 4

W13

W14

W15

BATTERY TRAY

H2

BATIK IKA I

K1

K9

K6/7

K4/5

K8

K3

unless otherwise noted

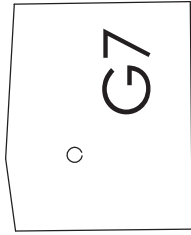
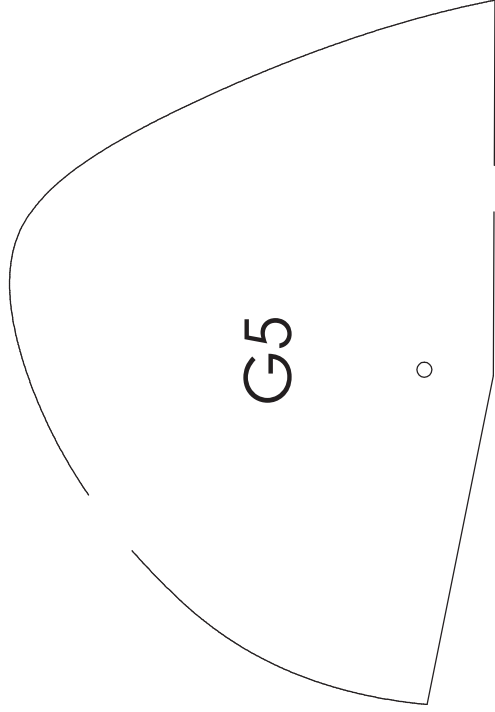

Make 4 each
of G5, G7,
and W5B

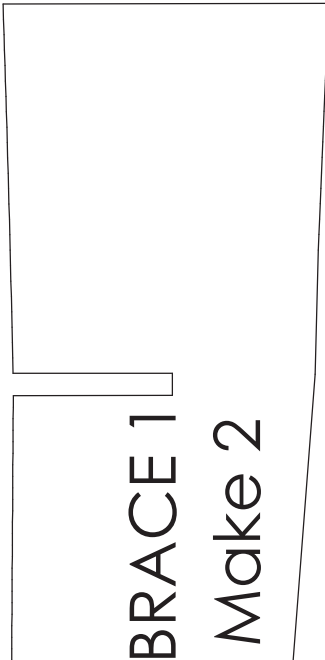
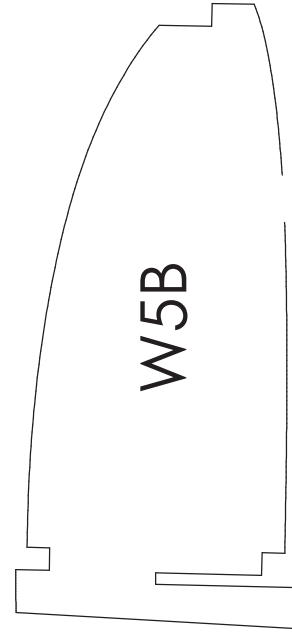

Make 2

3/4

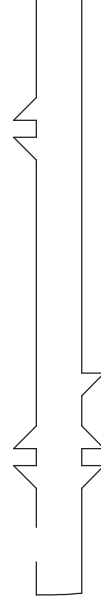
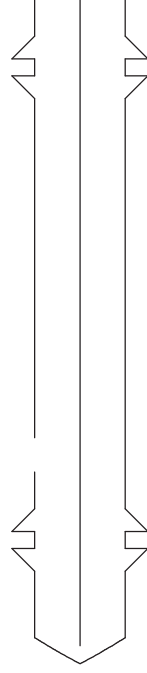

V1

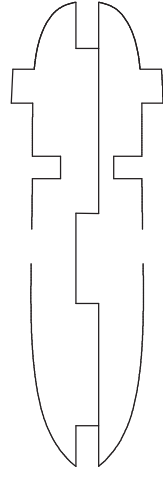

F10

C3

1/16" Balsa--make 2 o

W11

W10

W9

W8

W7

W6

A3

A9

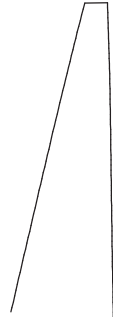
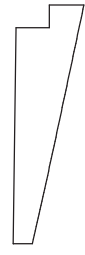
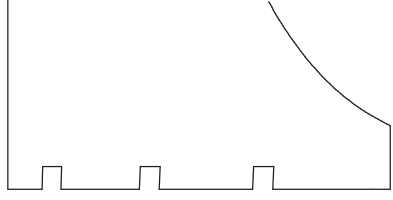
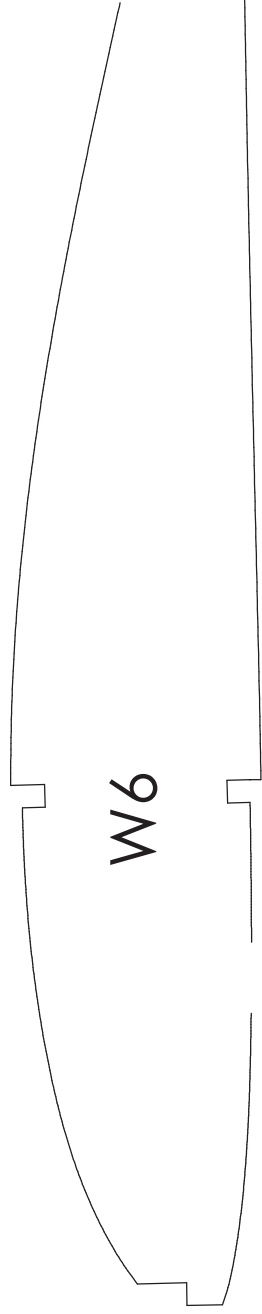
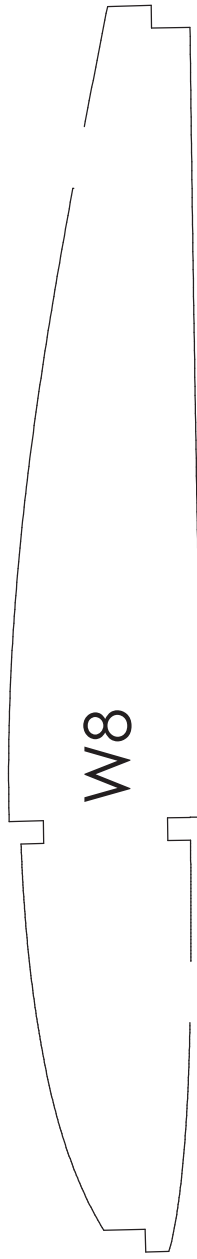
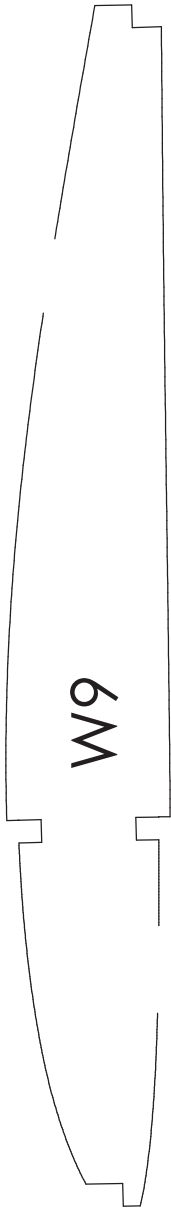
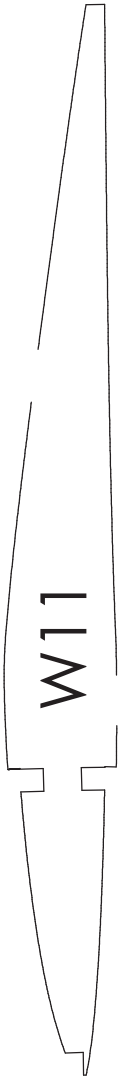

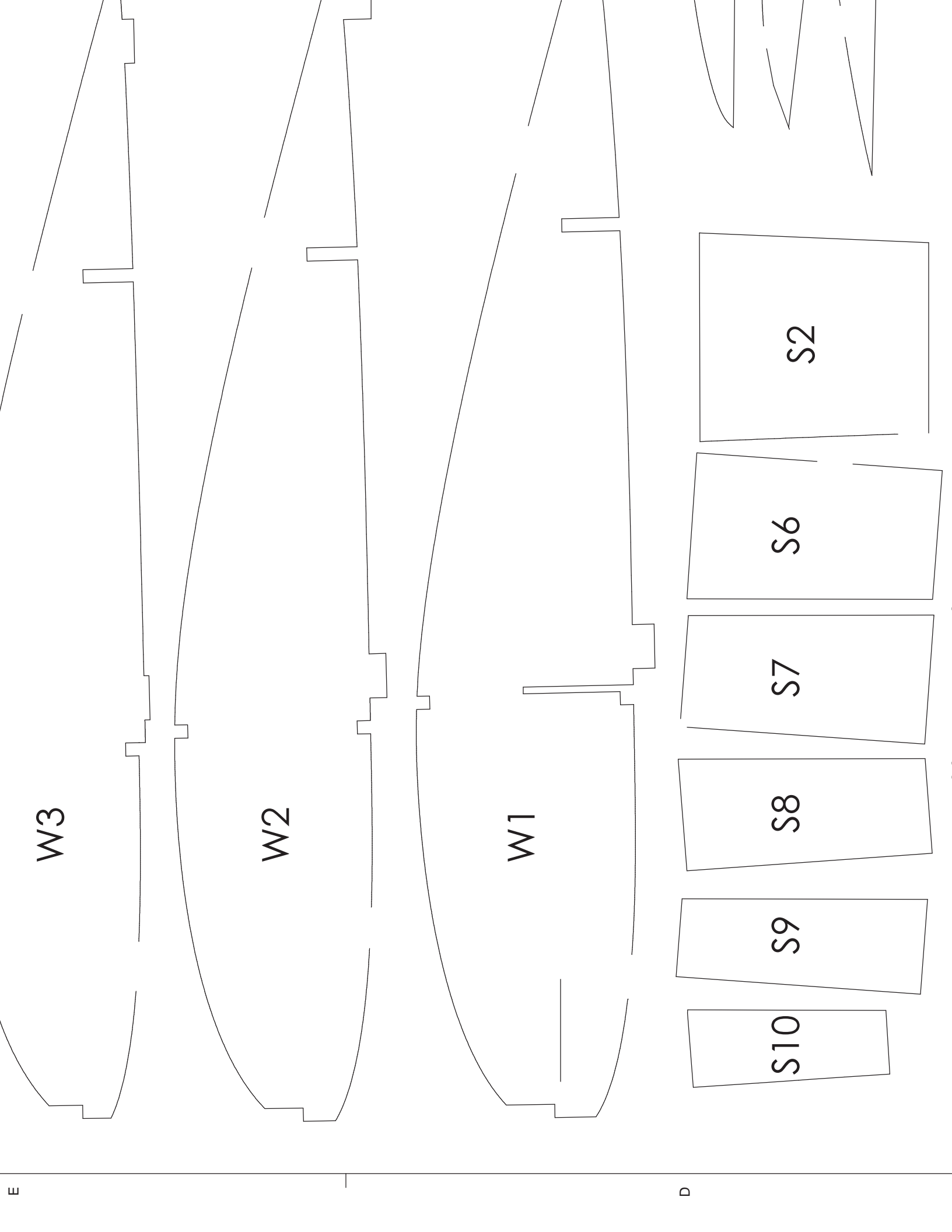

W3

W2

W1

S10

S9

S8

S7

S6

S2

S3

S4

S5

S1

S11

S12

S13

S14

S15

S16

E

D

Shear Webs

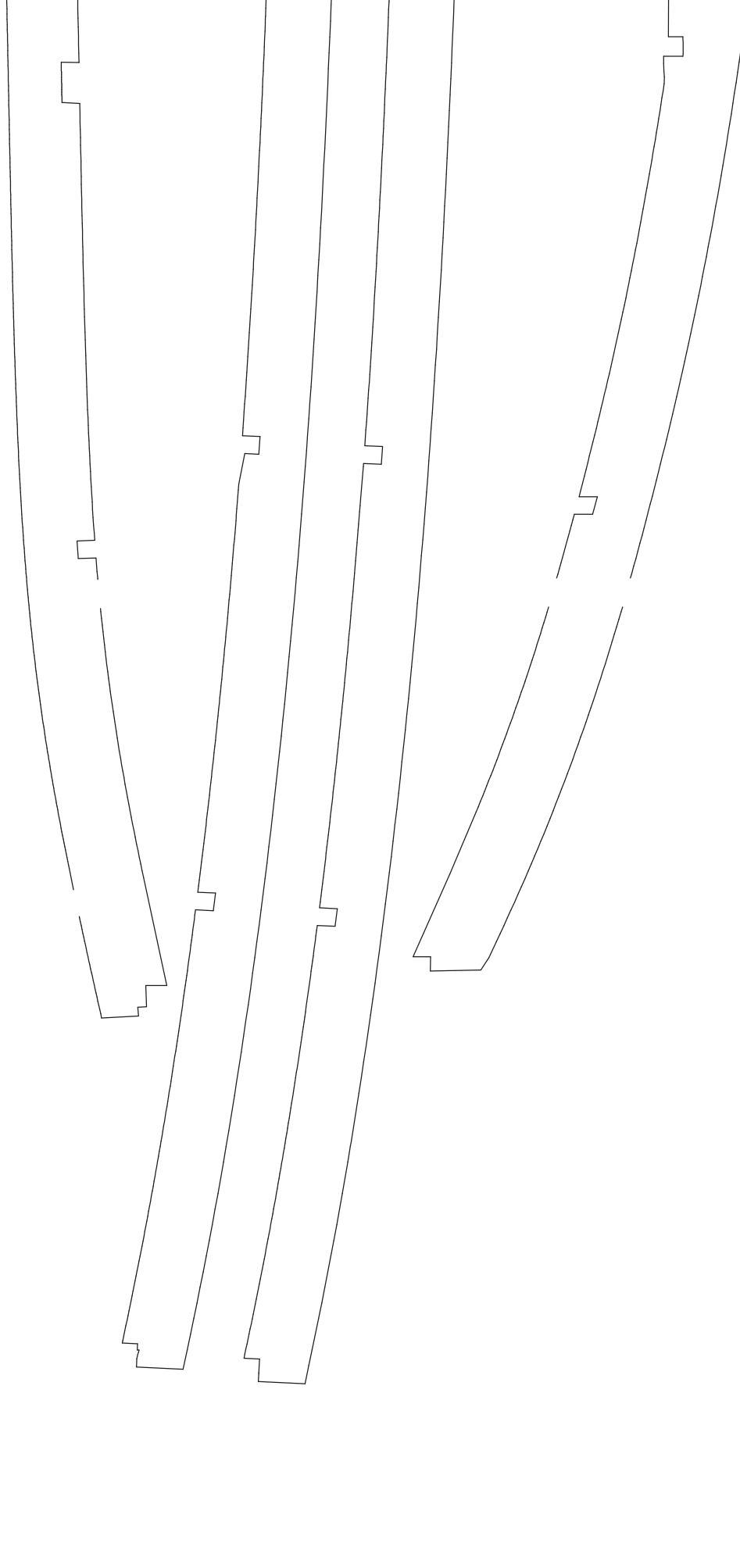

c

|

B

1/16" Ply--make one of each part

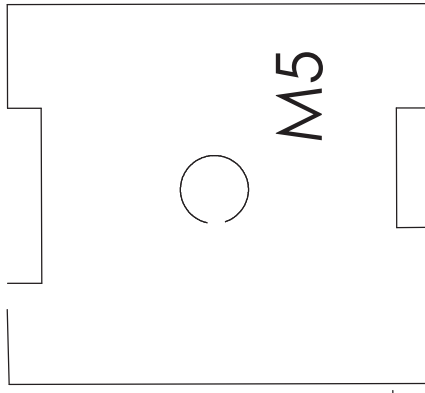
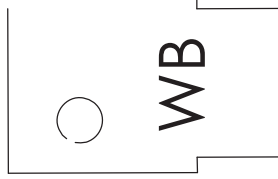
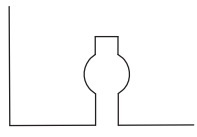
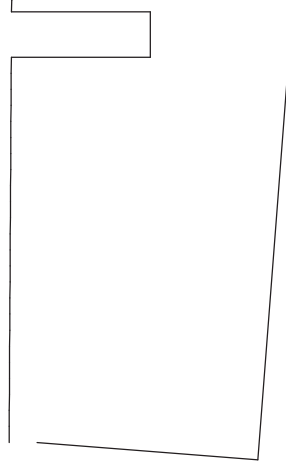
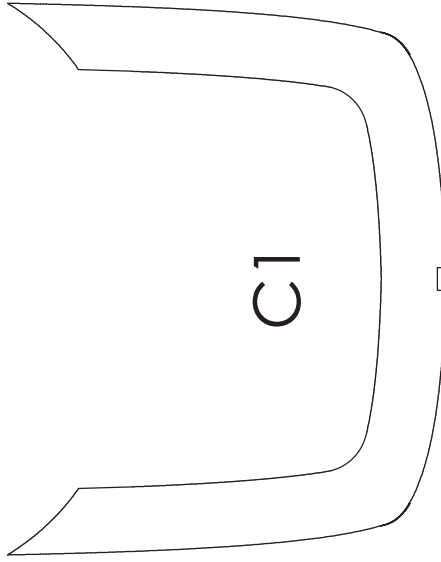
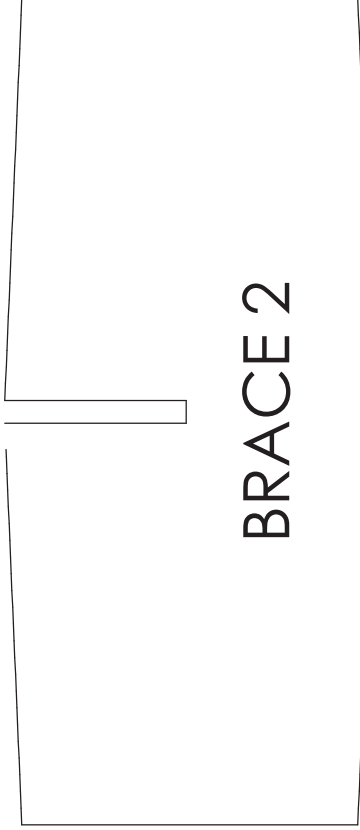
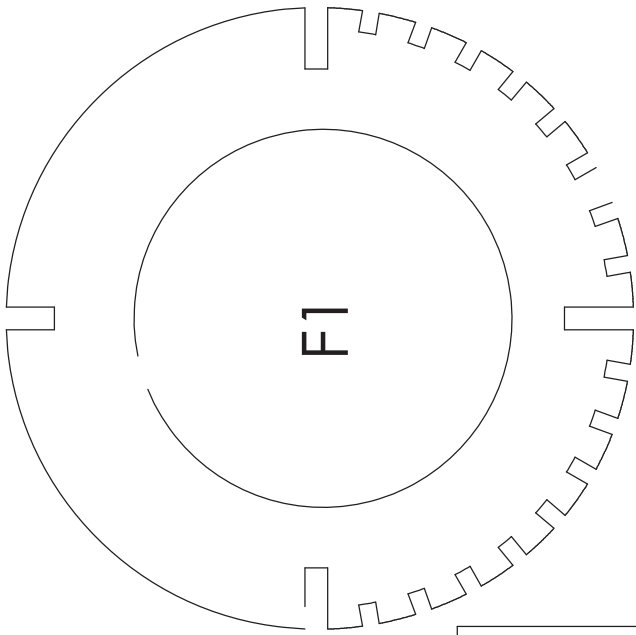

4

3

2

1

A

